

*South Village  
Community Development District*

*March 4, 2025*

# *AGENDA*



**South Village  
Community Development District**

475 West Town Place  
Suite 114  
St. Augustine, Florida 32092

*District Website:* [www.SouthVillageCDD.com](http://www.SouthVillageCDD.com)

---

February 25, 2025

Board of Supervisors  
South Village Community Development District

Dear Board Members:

The South Village Community Development District Meeting is scheduled for **Tuesday, March 4, 2025 at 6:30 p.m. at the Eagle Landing Residents Club, 3975 Eagle Landing Parkway, Orange Park, Florida 32065.**

Following is the advance agenda for the meeting:

- I. Roll Call
- II. Audience Comments (*regarding agenda items listed below*)
- III. Approval of Minutes of the February 4, 2025 Meeting
- IV. Discussion Items:
  - A. Suspension Letter
  - B. Notice of Performance Deficiencies
  - C. Funds Designated for Food & Beverage Operations
- V. Open Items
  - A. Laurel Valley Monument Signs
  - B. Slide Ladder
  - C. Gym Equipment Maintenance Plan
  - D. Reimbursement to the District for Late Fees from Huntington Bank
  - E. Reimbursement to the District for Lost Revenue of Golf Member Dues and Trail Fees

- VI. Consideration of Proposals
  - A. LED Light Conversion at the Tennis Courts
  - B. Street Light Replacement
- VII. Ratification of Requisitions – Series 2016 (084 & 085)
- VIII. Staff Reports
  - A. General Manager - Report
  - B. District Counsel
  - C. District Manager – Ethics Training
  - D. District Engineer
- IX. Supervisor’s Requests
- X. Audience Comments
- XI. Financial Reports
  - A. Balance Sheet as of January 31, 2025 and Statement of Revenues and Expenses for the Period Ending January 31, 2025
  - B. Assessment Receipt Schedule
  - C. Approval of Check Register
- XII. Next Scheduled Meeting: April 1, 2025 @ 6:30 p.m. @ Eagle Landing Residents Club
- XIII. Adjournment

**Board Oversight**

- A. *Chairman Payton* – Landscape Maintenance & Parks
- B. *Vice Chairman Warren* – Golf
- C. *Supervisor Frechette* – Food & Beverage
- D. *Supervisor Brink* – Aquatics Center
- E. *Supervisor Osbeck* - Athletics

*THIRD ORDER OF BUSINESS*

MINUTES OF MEETING  
SOUTH VILLAGE  
COMMUNITY DEVELOPMENT DISTRICT

The regular meeting of the Board of Supervisors of the South Village Community Development District was held Tuesday, February 4, 2025 at 6:30 p.m. at the Eagle Landing Residents Club, 3975 Eagle Landing Parkway, Orange Park, Florida.

Present and constituting a quorum were:

Chris Payton	Chairman
Glenn Warren	Vice Chairman
Allan Brink	Supervisor
David Frechette	Supervisor
Jennifer Osbeck	Supervisor

Also present were:

Marilee Giles	District Manager
Katie Buchanan	District Counsel
Alex Acree	District Engineer by telephone
Jim Hahn	General Manager, Honours Golf
Mitch Sayers	Assistant Superintendent of Golf
Joe Halifco	Food & Beverage
Scott Swenson	Facilities Manager
Jon Rowe	Golf Course Superintendent
Ernie Cruz	Golf Professional
Elana Barron	Membership Services
Dan Zimmer	Troon
Matt Hurley	Troon

The following is a summary of the actions taken at the February 4, 2025 meeting.

**FIRST ORDER OF BUSINESS**

**Roll Call**

Ms. Giles called the meeting to order at 6:30 p.m. and called the roll.

**SECOND ORDER OF BUSINESS**

**Audience Comments**

A resident stated I represent the neighborhood for the Oakland Hills fountain project. We were able to get 12 of the 18 homes in support of the fountain, but we are going to withdraw the

request at this time due to financial reasons. We might revisit this in the future. I want to thank the board for consideration of this project.

**THIRD ORDER OF BUSINESS**

**Approval of the Minutes of the January 7, 2025 Meeting**

On MOTION by Mr. Payton seconded by Mr. Waren with all in favor the minutes of the January 7, 2025 meeting were approved as presented.

**FOURTH ORDER OF BUSINESS**

**Discussion Items**

**A. Oakland Hills Fountain**

This request has been withdrawn.

**FIFTH ORDER OF BUSINESS**

**Open Items**

**A. Laurel Valley Monument Signs**

Mr. Hahn stated all the information has been submitted to Clay County.

**B. Slide Ladder**

Mr. Hahn stated we are working with Allan on this, and the entire slide stairs will be treated and painted. We also have a company coming in to check the seams of the slide and make sure it is in good working order and putting on a coat of fiberglass as well as repairing a leak on the main base at the top of the slide. Both projects will be done before spring break.

**C. Gym Equipment Repairs**

Mr. Hahn stated I'm working with Jennifer on the gym equipment. A new Stairmaster was purchased and is up and running. We check the equipment weekly, and we have a preventive maintenance plan with a company that checks it quarterly. I'm getting a quote to have it done bi-monthly.

**D. Reimbursement to the District for Late Fees from Huntington Bank**

Mr. Zimmer stated we continue to work with Huntington Bank and they have said they are going to credit it. Huntington went through a system conversion and their billing system platform

changed in October. This late fee is from August, and they are having difficulty getting the late fee credit into the new system.

**E. Reimbursement to the District for Lost Revenue of Golf Member Dues and Trail Fees**

Mr. Zimmer stated Ernie spent a lot of time with Jonas on pulling the historical use billings going back to 2019. From what we see in the dues billing versus what shows on the P&L, everything has been billed correctly. The fees that we need to verify is the trail fees. The information we are working with Jonas on is to be able to pull a specific period of time how many trail fee members did we have so we can then reference that and say we had 37 trail fee members; trail fees were \$1,000 and trail fee revenue was \$37,000 to verify everything was billed correctly.

Mr. Warren asked how are we going to account for people who went from the players card to a full membership but didn't get charged for two years? Nothing has changed since you were here two months ago. I know for a fact that a member who played every club championship, for over two years was still being charged as a players club. Your system sounds like it matches up because you had 37 carts and 37 matching, but we had 45 people that were riding around with stickers. We are never going to know how much money that Troon has lost us.

Mr. Zimmer stated the example you gave with someone was billed a players card but moved to a full member and for whatever period of time was not charged to use, we would not be able to pull that information out of the system because it wouldn't have been changed in the system from players card to a member. We couldn't go back and audit that specific situation.

Mr. Warren stated what I need Troon to admit is, I'm sorry I lost your money. You cannot correct this. I know another instance; I got kicked out of the club as a social member before I moved into the neighborhood. Nobody told me and for two more years I was coming up here they gave me social club access. Some of that started before Troon was here but it finished under Troon. This could be a ten year problem before Troon got here but the same person in charge in making sure we were being charged properly was the same person and Troon sounds like they audited to make sure we were charging membership right.

Mr. Zimmer stated to a certain level you are reliant on the person responsible for billing. I'm not sure what that audit would look like, that somebody playing golf had not been changed within the system. We can tell about the trail fee because those people have to come in and get a new cart sticker. That is not an automatic bill. We would be able to tell if there are 45 trail fee

members in the system but only 43 people came in and paid. If you have the specific information, please share with us who those are so we can look into that.

Mr. Warren stated I only know of a few but there are probably more based on being \$16,000 wrong last year that had to be corrected. Someone being charged as a single rather than the family rate over time adds up over time. It sounds like you can't correct that or track that to be able to tell us how much money Troon has lost us by not making sure.

Mr. Zimmer stated we can audit and make sure that within the Jonas point of sale system that the memberships are set up appropriately and when a member joins they are assigned the correct membership categories so when we run the dues at the end of every month those people are billed correctly.

Mr. Warren stated in five years you have never done an audit and you owe Ernie an apology because he has been screamed at because he has had to go to these people to collect and say we didn't charge you right this whole year, you owe us \$1,500, you didn't pay the cart fee and owe us \$1,200. He has done that to the tune of \$16,000. We had members quit because of the disputes. You are not going to figure out what you have lost.

**F. Gym Roof Repair**

Mr. Hahn stated the gym roof repairs have been completed.

**G. Repair to the Greens**

Mr. Warren stated Jon and I rode the course last Wednesday. He has assured me that he is being a little more liberal this time, instead of patching it, doing it right. I asked for quotes and got them and both purveyors said we should wait until the first week of April. The cost is around \$10,000. I don't think they need board approval to do that, but I think as a board we should say we want this done.

**H. Pickleball Gate**

Mr. Hahn stated the pickleball gate has been moved to a better location.

**SIXTH ORDER OF BUSINESS**

**Consideration of Proposals**

**A. Landscape and Irrigation Enhancements on the Island**

Mr. Hahn stated I sent to the board a quote from our landscape company to do the island. We took another soil sample and there is still a lot of ammonia in it and the soil needs to be treated. There is a three-step process to get the island back to where we would like to get it with landscaping. The first step is to treat the island. They want to pull all the wood chips off the island, till the soil, add Sulphur to the soil to neutralize the ammonia. That is \$3,100 to treat the island. Next step is redo the irrigation, the irrigation has not been functional in quite some time and that is about \$3,500. Then the island would be acceptable for planting and the cost of the planting is about \$9,600.

It does not have to be approved tonight because they wouldn't do the work until March, April or May when the weather is nicer.

Mr. Payton stated we can do the first two steps then we can discuss what's going in. You don't need board approval for the first two steps. Just get it going.

**B. Proposal for Light Pole**

Mr. Hahn stated the other proposal I sent to the board is the proposal for the light pole that was damaged. The pole is a standalone unit and the proposal is to replace the entire pole and is about \$16,000.

Mr. Payton stated given the cost of the pole we need to get more quotes.

**SEVENTH ORDER OF BUSINESS**

**Staff Reports**

**A. General Manager - Report**

Mr. Hahn gave an overview of operations report that covered operations of the amenity center, athletic center, tennis facility, golf and clubhouse operations, common areas, retention ponds, landscaping and outlined two proposals to update the lighting on the tennis courts in the total amount of \$12,000 and will place this item on the next agenda for board action.

**B. District Counsel**

There being none, the next item followed.

**C. District Manager**

There being none, the next item followed.



**D. District Engineer**

There being none, the next item followed.

**EIGHTH ORDER OF BUSINESS****Supervisor's Requests**

Additional comments: Surveys in various locations of the club, updates will be sent every two weeks, sound system at cabana bar, inspection of the roof, send reminders for survey, order for pro shop of merchandise and accessories, list of items on walk through of facility, rot/cracks in boards on court 1 and 2, rail on stairwell going up to the gym needs attention, paint closet floor, ball machine, put toiletries in bathroom, put hook on back of bathroom door, brick path by amphitheater to restaurant is in bad shape, competition pool and kids pool need to be cleaned better, cover adult pool at night, rags in weight room, TV in cabana bar not working, continually update Eagle Landing webpage, use of irrigation expenses under capital, filtration system bypassed on reuse water for golf course, junior tees ignored for over a year, sandboxes are better but need to be mowed next to tee markers, various drainage issues on certain holes, bunker on 17, thin pine trees on golf course, tee boxes on 13, 14, 17 & 8, surveys should be private, don't close kitchen early on game nights, have specials on game nights, benefit of pigment on golf course, recreation survey, send restaurant survey to residents, share event list with membership, water fixtures and sinks in on course restrooms have build-up on them, pavers are lifting in places, have contractor deal with root intrusion and reset entire walkway, letter of deficiency went to Troon, long term plan for greens replacement, update on the bird situation, restaurant's identity, club within a club, try to use portion of banquet room for dinners.

**NINTH ORDER OF BUSINESS****Audience Comments**

Additional comments: Start work on the course after April 14<sup>th</sup> golfers from other golf courses will be looking at our club, concerned about the significant amount of underbrush in the forest areas behind homes that pose a fire hazard, several concerns voiced about unacceptable behavior of a member and it not being addressed, the party involved has been suspended while investigation is going on and that will be addressed at the next meeting, process of having a person trespassed by an employee, motorcycles and electric bikes on walking paths, mulch disappearing from playground on Royal Pines due to drainage issue.

**TENTH ORDER OF BUSINESS**

**Financial Reports**

**A. Balance Sheet as of December 31, 2024 and Statement of Revenues and Expenses for the Period Ending December 31, 2024**

The balance sheet and income statement were included as part of the agenda package.

**B. Assessment Receipt Schedule**

The assessment receipt Schedule was included as part of the agenda package.

**C. Approval of Check Register**

On MOTION by Mr. Payton seconded by Mr. Warren with all in favor the check register was approved.

**ELEVENTH ORDER OF BUSINESS**

**Next Meeting Scheduled for Tuesday, March 4, 2025 at 6:30 p.m. at Eagle Landing Residents Club**

Ms. Giles stated the next meeting is scheduled for March 4, 2025 at 6:30 p.m. in the same location.

On MOTION by Mr. Payton seconded by Mr. Warren with all in favor the meeting adjourned at 8:24 p.m.

\_\_\_\_\_  
Secretary/Assistant Secretary

\_\_\_\_\_  
Chairman/Vice Chairman

*FOURTH ORDER OF BUSINESS*

*B.*



MANAGEMENT | DEVELOPMENT | MARKETING

Anne Kaufman  
SVP & Associate General Counsel  
Direct: (480) 477-0420  
akaufman@troon.com

February 24, 2025

South Village Community Development District

Attn: Marilee Giles

475 West Twon Place, Suite 114

St. Augustine, FL 32092

VIA FEDERAL EXPRESS OVERNIGHT AND ELECTRONIC MAIL

Re: Troon's Response to Notice of Performance Deficiencies related to the Management Services Agreement by and between the South Village Community Development District (the "District") and Honours Golf Company, L.L.C. dated July 31, 2018 (the "Agreement")

Dear Ms. Giles,

I am an attorney with Troon Golf, L.L.C., parent company of Honours Golf Company, L.L.C. (collectively, "Troon"). This letter is in response to your Notice of Performance Deficiencies you sent to Troon dated January 30, 2025 regarding the Agreement ("Notice").

As a preliminary matter, Troon takes the satisfaction of the District, community residents, and the members of Eagle Landing Golf Club (the "Club") very seriously and has always strived to meet or exceed our operational standards and the standards expected. We value our relationship with the District, and hope to continue serving the District, community residents, and the Club's members and guests pursuant to our Agreement. We do not believe any of the issues raised in the Notice constitute an Event of Default, as outlined in Section 10 of the Agreement, nor was any such allegation made. We appreciate the opportunity to address the concerns raised in a collaborative manner with the District. We have approached these issues with genuine attention and care, involving several members of our team in the process, including Vice President of Operations, Dan Zimmer. As such, many of the issues included in your Notice have already been remedied or will be remedied in the near future, as discussed below.

**Athletic Center Maintenance**

Issue: "Unreasonable delay in the coordination of repair the Athletic Center's roof, despite the District's request that the Manager secure cost estimates for the District's consideration."

Remedies: Certain roof repairs were completed in the summer of 2024, but unfortunately, they were not effective. As a result, in December 2024, additional vendors were consulted to inspect the roof and provide repair estimates. This process took longer than anticipated due to the holiday season. However, the selected vendor submitted a quote on January 13, 2025, and the necessary roof repairs were successfully completed on January 24, 2025.

Issue: "Failure to perform regular inspections of the Fitness Center's gym equipment to ensure proper functionality and safety; Failure to conduct repairs and maintenance of the Fitness Center's gym equipment or follow manufacturer guidelines to ensure the equipment's performance and longevity."

**Remedies:** Currently, Club employees conduct daily visual inspections of the fitness equipment. A repair log is posted in the fitness area, allowing residents to report any malfunctioning equipment. We address each issue as quickly as possible, and if a repair cannot be completed in-house, we coordinate with our equipment vendor for service. Additionally, the Club has a contract with our fitness equipment company for quarterly preventative maintenance. During these visits, the company inspects all equipment and notifies Troon of any issues requiring further attention.

While we believe this system has been effective, we recognize residents' concerns and are implementing a new Property Checklist for the fitness area. This checklist will require staff to regularly test all equipment to ensure proper functionality and make necessary adjustments or repairs. We are also researching the cost of increasing preventative maintenance visits from quarterly to monthly or bi-monthly. This information will be presented to the Board at the March meeting for consideration.

**Issue:** “Failure to clean and sanitize equipment, floors, and other surfaces as needed using appropriate cleaning agents to maintain a hygienic environment that complies with health and safety regulations.”

**Remedies:** The fitness area is cleaned daily by our cleaning staff, ensuring all equipment, floors, and bathrooms are well-maintained. Additionally, the fitness counter staff assists with equipment cleaning during their routine walk-through inspections. In January, we hired a full-time maintenance person, who has already made a positive impact by addressing necessary repairs, painting, and deep cleaning in the fitness area. This new position will enhance overall cleanliness not only in the fitness area but throughout our operations. To further improve cleanliness standards, our new Property Checklist will include regular cleaning reviews, ensuring consistent maintenance and attention to detail.

### **Aquatic Facilities**

**Issue:** “Failure to repair and/or replace broken lavatories.”

**Remedies:** We address any issues with toilets, urinals, sinks, and drains immediately upon discovery. In the past 4–5 months, we encountered one major issue that required assistance from an external company, which extended the repair timeline; however, the facilities remained operational throughout. All other repairs have been efficiently handled by our in-house staff, ensuring units are reopened as quickly as possible. With the addition of a new full-time maintenance person, repairs will be completed even more swiftly.

**Issue:** “Failure to perform regular pool equipment inspections to ensure proper functionality and safety.”

**Remedies:** Our team conducts daily inspections of the pool systems, ensuring all pumps are functioning optimally and set correctly, cleaning filters, checking chemical pH levels, and verifying that all systems are in proper working order. The Club partners with Poolsure, an external company responsible for delivering chemicals, inspecting chemical equipment and lines, and ensuring the chemical system operates efficiently. Poolsure visits the Club approximately every two weeks. For pool pump concerns beyond our staff's capabilities, we collaborate with a specialized pump company for prompt repairs. As a result, our pump systems rarely experience prolonged downtime. Additionally, health inspections are conducted throughout the year to ensure our pools remain clean and safe.

Each year, we perform preventative maintenance on the slide before the summer season begins. This process includes inspecting and sealing all seams, sanding, recoating, and conducting a comprehensive evaluation to ensure it is in top condition. Painting of the slide stairs is scheduled for the last week of February and the coating and refurbishing of the slide is scheduled for the first week of March.

We are also in the process of hiring a new Recreational Manager with expertise in pool care and maintenance. This position will be filled well before the summer season to further enhance the quality and upkeep of our facilities.

Issue: “Failure to regularly clean pool walls, floor, tile, filters, and other systems as needed.”

Remedies: From May to October, during the busy season, we maintain a full operating staff, including all required lifeguards, every day of the week. During this time, the pools are thoroughly cleaned each morning and again after closing, with additional touch-ups throughout the day due to heavy use by residents and guests.

In the off-season from November to May, staffing is significantly reduced, lifeguards are not on duty, the slide and diving boards are closed, and water temperatures drop, leading to fewer visitors. While our team continues to clean the pools daily, limited staff means that debris may accumulate later in the day. Weather conditions also play a major role in pool cleanliness—during rainy and windy periods, such as those in December and January, pools may be cleaned in the morning but still collect leaves and debris by the afternoon.

Despite these challenges, we undergo regular health inspections year-round, including in winter, and have never received warnings regarding pool maintenance or cleanliness. To further enhance oversight, our new Property Checklist will serve as an additional tool for managing the pool area moving forward.

### **Golf Course**

Issue: “Failure to address deteriorating landscape and greens conditions and implement a golf course turf management plan to improve playability and player satisfaction.”

Remedies: The scope of work for sodding weak areas on the greens has been finalized and was presented to the Board of Supervisors at the February meeting. The project is scheduled for completion in the first week of April 2025, though the timeline may be adjusted based on event schedules or weather conditions. Any changes will be reviewed with Supervisor Warren before approval. Furthermore, the Annual Agronomy Plan for the 2025 growing season is nearing completion and will be shared with Supervisor Warren by February 21st.

Enhancing golf course playability and overall experience remains a priority. In 2024, we received 887 responses to the golfer survey distributed to public players through our EZ-Links Tee Sheet system. The course earned an average rating of 4.5 out of 5, with a 92% recommendation rate.

Issue: “Failure to address stormwater and irrigation issues affecting the golf course, including ensuring sufficient staff availability to address maintenance needs.”

Remedies: As the course has aged, certain low-lying areas have developed drainage issues, retaining water longer due to slower runoff, tree cover, and limited sunlight. Cold weather and prolonged wet conditions over the past few months have further exacerbated these challenges. To address these issues, we have installed additional drainage lines, removed select trees, and applied extra top-dressing and aerification to improve turf conditions. As a result, these areas are now in significantly better shape. However, further improvements are needed, including additional tree removal, enhanced drainage, and leveling of “bird bath” areas on several greens. This work is scheduled for completion by April 30th.

Issue: “Failure to maintain operational equipment.”

Remedies: A full-time mechanic is on staff to maintain the equipment fleet, with no restrictions or limitations on necessary repairs. However, much of the current fleet is six years old with high operating hours, leading to an increased need for repairs. To address this, several new pieces of equipment have been ordered and are scheduled for delivery within the next 60 days. This upgrade will significantly reduce the maintenance workload, allowing the team to shift focus to preventive care, minor repairs, and routine adjustments for the new fleet. Additionally, an equipment repair update will now be included in the Monthly Operations Report to keep the Board informed of any major repairs.

Over the past 30 days, bunker rakes on the course have been replaced, water station containers have undergone deep cleaning, and staff has reviewed procedures for moving sand buckets on par-3 holes. Efforts have also been made to improve the placement of junior tees, with formal tees set to be established once the growing season begins.

Issue: “Failure to implement desired golf operations as requested by the Board and agreed to by various management employees, including golf course starter actions and first tee management.”

Remedies: A new focus for the starter/player assistant role was developed and discussed 45-60 days ago, and has been shared with the Board. This includes updated scripts for members and public players, a daily information sheet, and a new staging location where starters can meet and engage with players. Information about these changes was emailed to members multiple times over the past 45 days, requesting feedback and ensuring that staff is following the new plan. We are also working closely with our staff on effectively managing start times and ensuring proper flow on both the 1st and 10th tees. Several staff meetings and training sessions have been held to implement these new processes. If necessary, adjustments will be made to ensure the plan is followed consistently.

### **Food & Beverage**

Issue: “Failure to clean and sanitize equipment, floors, and other surfaces as needed, including indoor and outdoor spaces where food and beverages are served, using appropriate cleaning agents to maintain a hygienic environment that complies with health and safety regulations.”

Remedies: We believe the cleaning and sanitizing procedures we implement comply with health and safety regulations. Such processes include, but are not limited to:

- A cleaning associate is on staff seven days a week to maintain all areas of the F&B operation, including the bar, bathrooms, patio, seating areas (both bar and back room), and entrance areas.
- Daily checklists are completed for both front and back of house, covering morning, mid-shift, and closing tasks, including cleaning in each area.
- The outside patio area and furniture are pressure washed every Friday, weather and business permitting.
- Regular State Health Inspections are conducted, and reports confirm that we maintain a clean, safe, and sanitized restaurant.
- Ecolab performs monthly preventative inspections of all F&B equipment, including the restaurant, café, and Cabana Bar. They also inspect sanitation, facility care, pest control, and structural issues. Ecolab reports indicate no concerns in any of these areas.
- TWC conducts semi-annual preventative maintenance on all bar coolers, ice machines, and dishwashers.
- A monthly preventive maintenance program is in place for all HVAC units throughout the building.
- A new full-time maintenance associate was hired in February to expedite repairs, assist with cleaning and daily upkeep as needed, and help with any necessary projects.

Issues: “Failure to provide food and beverage of satisfactory quality and variety; Failure to ensure adequate staffing to meet guests needs.”

Remedies: The approved Fiscal Year 2025 budget included adjustments to the F&B operation with the goal of achieving a break-even position. Details of the operational and staffing changes were reviewed with the Board of Supervisors during budget meetings and outlined in the August 23, 2024 Assessment Report by David Plevin, Troon’s Corporate Director of Food & Beverage. The plan was implemented, and feedback on menu options and the overall experience varied. After further discussions with the Board, direction was provided in the December meeting to expand the menu options and return kitchen staffing to previous levels. Additionally, an Assistant F&B Manager position was created to increase managerial



presence in the restaurant and improve the enforcement of community rules and regulations. Below is a summary of what has been implemented so far:

- A guest experience survey for the restaurant, distributed via QR codes in the restaurant and emailed to residents.
- A new appetizer menu launched the week of February 10th.
- A new entrée menu is scheduled to launch by the end of February, with plans for semi-annual reviews and adjustments based on sales volume, seasonality, and guest preferences.
- The new Assistant F&B Manager began in the last week of January.
- The hiring process for part-time kitchen staff is underway and will coincide with the new menu launch.

While the implemented changes are expected to improve the overall experience, we believe further discussions are needed to clearly define the vision for the restaurant. Chairman Payton has requested that all Supervisors provide input on this vision. Once this input is gathered, our recommendation is to schedule a Board workshop meeting, where all ideas can be shared, along with survey data, market analysis, comparable operations, and historical financial data. With a clearer vision, aligning operations will be much more straightforward.

Issue: “Failure to ensure the quality of service by failing to enforce District policies governing the amenity facilities, including prohibiting smoking/vaping, use of profanity, etc.”

Remedies: One of the main reasons for adding the Assistant F&B Manager position is to provide more senior management oversight during restaurant operating hours. This position will primarily work later in the day and into the evening, allowing for swift and professional handling of policy and conduct issues. Any documented and verified reports of unacceptable behavior or actions by residents, members, or guests will result in recommended “facility suspensions” for members/residents and the issuance of a “trespass warrant” for public guests. There will be no exceptions, and prompt action will be taken to address any form of unacceptable behavior.

### **Management Services**

With regards to contents of the Annual Plan as well as our other management duties, Troon will continue to operate the Facility in accordance with the Agreement and please contact Dan Zimmer if you feel that we are not meeting our obligations.

Based on the foregoing, Troon has remedied, or will remedy in the near future, the alleged performance deficiencies. We will continue to communicate with you regarding our progress. As stated previously, Troon appreciates your business and we look forward to continuing to serve the District and the Club. If you have any questions or concerns, please contact me or Dan Zimmer.

Sincerely,



Anne Kaufman  
SVP, Associate General Counsel

cc: Dan Zimmer - VP of Operations  
Matt Hurley - EVP, Managed Properties East  
Jeff Hansen - EVP, General Counsel

*C.*



To: Chris Payton Chairman, and members of the SVCDD Board

CC: Jim Hahn GM Troon, Marilee Giles GMS

From; Joe Halifko, Food and Beverage Director Troon /Eagle Landing Golf Club

Chris it was my plan to add the following to the agenda for the next meeting, but I wasn't able to complete my summary quickly enough. I would like to discuss the direction given in regards to the food and beverage operation.

The discussion surrounding the partial return of the assessment funds redirected to the golf capital fund, the board had agreed to the movement of 50k to recreation, and 100k to the club for additional manager staff and immediate needs, such as the partial restoration of the menu items.

The menu has been updated as directed. The upgrade of the appetizers, and salads. The continuation of the menu restoration will require not only the additional labor, but additional equipment as well.

The issue of labor has escalated this need as well. We have turned-over our most senior line cook. Competition is tough the average compensation for line cooks of the caliber needed is \$20-\$24 dollars per hour in our market. We have fast food counter staff making higher wages than our culinary staff. This is not due to any lack of effort to keep up with the market on our part. The industry has simply been so severely impacted since the pandemic, with the lack of qualified applicants; it has driven the wages much more quickly than we can keep up with the budget restrictions. Additionally we have been asked, not to reduce hours of operation, or menu offerings.

These factors require the request of 100k of the assessments to be added back to the operation. These funds will bring the total to 250k. This will still allow 100k of the assessment to remain in the golf capital fund. The following are the needs we have addressed, and or intend to address with the funds.

- 70-85k in addition labor (2 addition culinary staff, and competitive increases to maintain critical staff, in the culinary department)
- 18-20k in equipment vital to operations and entrée production
- 1-2k catering equipment replacement
- 2-3k storage (modular)
- Replacement and/or additional computer hardware (monitors/printers ect)

I hope we can move forward, so we can continue the implementation of the menu, along with securing the functionality of the operation considering our current needs. I do not wish to imply that this adjustment will have create expedient growth, but will address the wants and needs of the residents, along with additional income that will overtime allow a self sufficient operation.

Regards, Joe

*SIXTH ORDER OF BUSINESS*

*A.*

# Jim Hahn

**From:** Jim Hahn  
**Sent:** Wednesday, January 15, 2025 10:40 AM  
**To:** Jim Hahn  
**Subject:** FW: New Quote from 1000Bulbs.com



**Jim Hahn | General Manager**  
o 904.637.0648 | [jhahn@troon.com](mailto:jhahn@troon.com)



**DISCOVER**  
THE TROON EXPERIENCE



You don't often get email from [nours@1000bulbs.com](mailto:nours@1000bulbs.com). [Learn why this is important](#)



## Sales Proposal

**Quote #:** 7975840    **Date:** 01/14/25    **Date Quote Written:** 01/14/25    **Expiration Date:** 04/14/25

### Salesperson

Nick Ours  
1475 Republic Pkwy Ste 100  
Mesquite, TX 75150  
[nours@1000bulbs.com](mailto:nours@1000bulbs.com)  
p. 972-543-0561  
f. 972-764-5926

### Bill To

Mark Arrowsmith  
Eagle Landing  
Mark Arrowsmith  
3979 Eagle Landing Pkwy  
Orange Park, FL 32065  
9045346440

### Ship To

Mark Arrowsmith  
Eagle Landing  
Mark Arrowsmith  
3979 Eagle Landing Pkwy  
Orange Park, FL 32065  
9045346440

Qty	Product	Price
32	 <b>HALCO-24907</b> 43,200 Lumens - 300 Watt - 5000 Kelvin - LED Flood Light Fixture - 145 Lumens Per Watt - Replaces a 1000 Watt Metal Halide - Slipfitter Mount - 0-10 Volt Dimmable - 120-277 Volt - Halco 24907	\$385.54

**Subtotal** \$12,337.28  
**Dropship** \$0.00  
**Total** \$12,337.28

# LED COURTBLADE (XARL)



## DOE LIGHTING FACTS

Department of Energy has verified representative product test data and results in accordance with its Lighting Facts Program. Visit [www.lightingfacts.com](http://www.lightingfacts.com) for specific catalog strings.

LIGHT OUTPUT - XARL			
		Lumens (Nominal) Type FT	Watts (Nominal)
Cool White	HO	60,145 <sup>1</sup>	547
Neutral White	HO	58,040 <sup>2</sup>	547

LED Chips are frequently updated therefore values may increase.

- 1- Verified by ITL Report  
ITL 86921 (Available upon request)
- 2- Verified by ITL Report  
ITL 86920 (Available upon request)

US patent D726,947 7,828,456 8,002,428 8,177,386 8,434,893 8,567,983 and US & Int'l. patents pending

**SMARTTEC™** - LSI drivers feature integral sensor which reduces drive current, when ambient temperatures exceed rated temperature.

**ENERGY SAVING CONTROL OPTION** - DIM - 0-10 volt dimming enabled with controls by others.

**EXPECTED LIFE** - Minimum 60,000 hours to 100,000 hours depending upon the ambient temperature of the installation location. See LSI web site for specific guidance.

**LEDS** - Select high-brightness LEDs in Cool White (5000K), or Neutral White (4000K) color temperature, 70 CRI.

**DISTRIBUTION/PERFORMANCE** - High performance, multi-faceted, reflector provides uniform Forward Throw (FT) distribution with sharp backlight cutoff. Photometric data is tested in accordance with IESNA guidelines

**HOUSING** - One-piece, die-formed aluminum housing contains factory prewired driver in a gasketed, weather-resistant wiring compartment. Hinged wiring access door (with safety lanyard) located underneath. Fixture is IP65 rated.

**OPTICAL UNIT** - Clear tempered optical-grade flat glass lens permanently sealed to weather-tight aluminum optic frame (includes pressure-stabilizing breather).

**MOUNTING** - The fixture is furnished with installed stainless steel, threaded mounting studs protruding from the rear of the housing. Stainless steel nuts and washers used to secure the fixture to the bracket are also included.

**ELECTRICAL** - Two-stage surge protection (including separate surge protection built into electronic driver) meets IEEE C62.41.2-2002, Location Category C. Available with universal voltage power supply 120-277VAC (50/60Hz input) and 347-480 VAC.

**DRIVER** - Available in HO (High Output) drive current. Components are fully encased in potting material for moisture resistance. Driver complies with FCC standards. Driver and key electronic components can be easily accessed.

**OPERATING TEMPERATURE** - -40°C to +50°C (-40°F to +122°F)

**FINISH** - Fixtures are finished with LSI's DuraGrip® polyester powder coat finishing process. The DuraGrip finish withstands extreme weather changes without cracking or peeling.

**WARRANTY** - LSI LED fixtures carry a limited 5-year warranty.

**PHOTOMETRICS** - Please visit our web site at [www.lsi-industries.com](http://www.lsi-industries.com) for detailed photometric data.

**SHIPPING WEIGHT (in carton)** - 55 lbs./24.9Kg

**LISTING** - UL listed to US and international safety standards. Suitable for wet locations.

This product, or selected versions of this product, meet the standards listed below. Please consult factory for your specific requirements.



Fixtures comply with ANSI C136.31-2010 American National Standard for Roadway Lighting Equipment - Luminaire Vibration 1.5G requirements.

**LSI XARL FT LED HO CW UE SVG DIM-LED FIXTURE**



Project Name \_\_\_\_\_ Fixture Type \_\_\_\_\_  
Catalog # \_\_\_\_\_

11/24/20  
© 2020  
LSI INDUSTRIES INC.

# LED COURTBLADE (XARL)

## LUMINAIRE ORDERING INFORMATION

TYPICAL ORDER EXAMPLE: **XARL FT LED HO CW UE WHT**

Prefix	Distribution	Light Source	Drive Current	Color Temperature	Input Voltage	Finish	Options
XARL	FT - Forward Throw	LED	HO - High Output	CW - Cool White (5000K) NW - Neutral White (4000K)	UE - Universal Voltage (120-277V) 347-480 - Universal Voltage (347-480V)	BLK - Black BRZ - Bronze GPT - Graphite MSV - Metallic Silver PLP - Platinum Plus GRN - Green WHT - White	DIM - 0-10V Dimming (from External Signal)

	Single	1.2
	D180°	2.4
	D70°	1.8
	Q90°	4.3

Note: House Side Shield adds to fixture EPA. Consult Factory.

Description	Order Number
XLCL-FT-HSS RM - External House Side Shield (Black only - rear mounted)	610098BLK <sup>1</sup>
FK120 - Single Fusing (120V)	FK120 <sup>2</sup>
FK277 - Single Fusing (277V)	FK277 <sup>2</sup>
DFK208,240 - Double Fusing (208V, 240V)	DFK208,240 <sup>2</sup>
DFK480 Double Fusing (480V)	DFK480 <sup>2</sup>
FK347 Single Fusing (347V)	FK347 <sup>2</sup>

120V	4.6 amps
208V	2.6 amps
240V	2.3 amps
277V	2.0 amps
347V	1.6 amps
480V	1.2 amps

Bracket Designation	Bracket Type	Bracket Configuration	Length	Bracket Finish
BRKT - Extension Bracket <sup>3</sup>	BO - Bolt On	S - Single	38"	BLK - Black BRZ - Bronze GPT - Graphite MSV - Metallic Silver PLP - Platinum Plus GRN - Green WHT - White
BRKT - Pole Top Hub <sup>4,5</sup>	4ESF - External Slipfitter	S - Single D180 - Double D70 - Double D90 - Double Q90 - Quad Q70 - Quad	*	

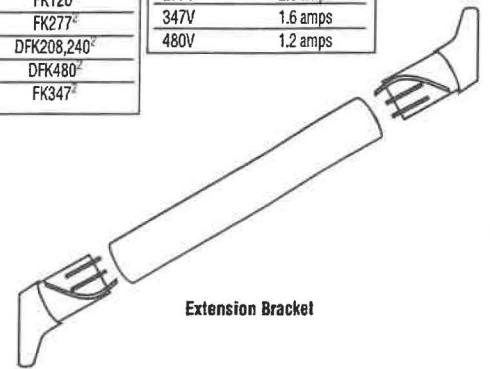

### FOOTNOTES:

- House Side Shields add to fixture EPA. Consult factory.
- Fusing must be located in hand hole of pole.
- One extension bracket is required per fixture.
- Pole top hub will fit over 4" OD pole or 5" OD pole with 4" tenon.
- Cap is included with pole top hub.

### DIMENSIONS

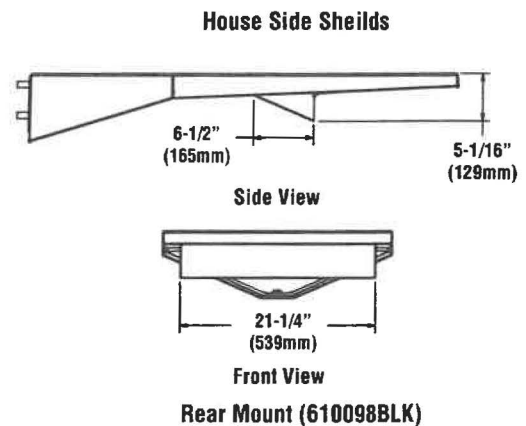
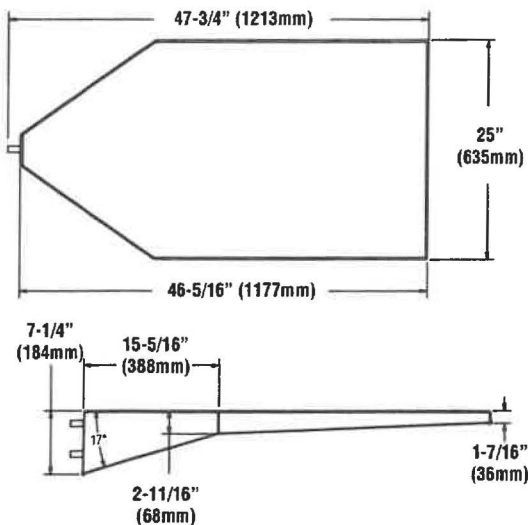

### BUG CHARTS

#### XARL- TYPE FT

Drive Current	Color Temp.*	Lumens	Watts	LPW	BUG Rating
HO	CW	60,145	547	110	B5-U0-G5
	NW	58,040	547	106	B4-U0-G5

\* Color Temperature: NW-4000K, CW-5000K



Project Name \_\_\_\_\_ Fixture Type \_\_\_\_\_  
Catalog # \_\_\_\_\_

11/24/20  
© 2020  
LSI INDUSTRIES INC.





# ORDER/QUOTE FORM

**TECHLIGHT**  
INNOVATION IN ILLUMINATION

Quote

Required Field  
Select One

Order

## SALES PERSON

**BEAU SUMMERSILL**

National Sales Director - Sports Lighting Division

2707 Satsuma Dr. | Dallas, TX 75229  
CELL: 910.358.9775 TOLL: 800.225.0727  
EMAIL: bsummersill@techlight.com

02/21/2025

## CUSTOMER INFO.

NAME	PHONE #	CUSTOMER PO#	CREDIT APPROVED	TERMS
Jim Hahn	847.922.9920	Eagle Landing Retro 4 Courts	<input type="radio"/>	<input type="radio"/>
SOLD TO: Eagle Landing		SHIP TO: Eagle Landing		
BILL TO: Eagle Landing		3989 Eagle Landing Parkway Orange Park FL		
ATTN: Jim		ATTN: Jim		

## FREIGHT OPTIONS

ALLOWED

PREPAID

PP & ADD

QTY	MARK	PART # / DESCRIPTION	UNIT PRICE	TOTAL
32		CTA M C 39L T4 1 BK	\$ 485.00	\$ 15,520.00
32		Custom 4" Round GALV Adapters BK	\$ 105.00	\$ 3,360.00
		Freight Allowed	\$ 0.00	\$ 0.00
		Taxes May Apply	\$ 0.00	\$ 0.00
			\$ 0.00	\$ 0.00
			\$ 0.00	\$ 0.00
			\$ 0.00	\$ 0.00
			\$ 0.00	\$ 0.00
			\$ 0.00	\$ 0.00
			\$ 0.00	\$ 0.00
			\$ 0.00	\$ 0.00
			\$ 0.00	\$ 0.00
			SUBTOTAL	\$ 18,880.00
			FREIGHT	\$ 0.00
			TAX	\$ 0.00
			TOTAL	\$ 18,880.00

ORDER / QUOTE EXPIRATION TIMEFRAME (DAYS):

Required Field:  
**30 Days**



**TECHLIGHT**  
 2707 SATSUMA  
 DALLAS, TX  
 75229

Project:  
**EAGLE  
 LANDING  
 TENNIS**

Notes:

FILE:  
 eagle.agi

Date:  
 1-13-25

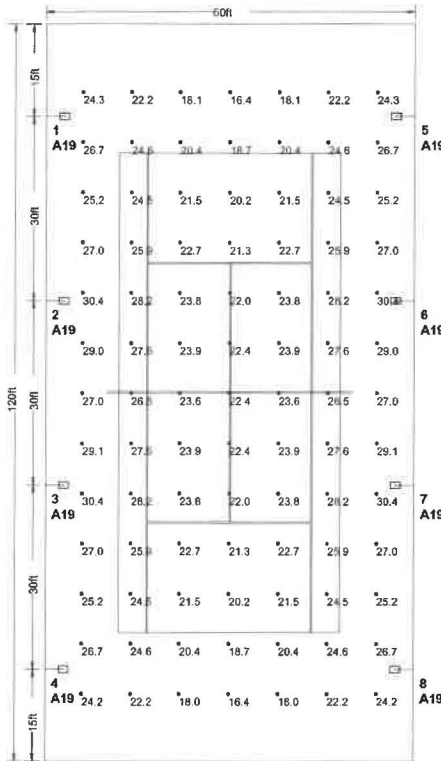

Symbol	Qty	Label	Lumens/Lamp	Arrangement	LLF	Description
[Symbol]	8	A19	N.A.	Single	0.900	CTA M C 39L T4-39,000 LUMEN TYPE 4 LED

Label	CalcType	Units	Avg	Max	Min	Avg/Min	Max/Min
COURT	Illuminance	Fc	24.20	30.4	16.4	1.48	1.85

LumNo	Label	Z-luminaire height	Tilt
1	A19	23	0
2	A19	23	0
3	A19	23	0
4	A19	23	0
5	A19	23	0
6	A19	23	0
7	A19	23	0
8	A19	23	0

- Notes:
1. Calculation 3' AFG.
  2. Based on 23' AFG fixture mounting including 20' poles plus 3' davit arm.
  3. This plan does not compensate for objects that might block light such as wind/privacy screens.

- DUE TO CHANGING LIGHTING ORDINANCES IT IS THE CONTRACTOR'S RESPONSIBILITY TO SUBMIT THE SITE PHOTOMETRICS AND LUMINAIRE SPECS TO THE LOCAL INSPECTOR BEFORE ORDERING TO ENSURE THIS PLAN COMPLIES WITH LOCAL LIGHTING ORDINANCES.  
 - THIS LIGHTING DESIGN IS BASED ON INFORMATION SUPPLIED BY OTHERS. CHANGES IN ELECTRICAL SUPPLY, AREA GEOMETRY AND OBJECTS WITHIN THE LIGHTED AREA MAY PRODUCE ILLUMINATION VALUES DIFFERENT FROM THE PREDICTED RESULTS SHOWN ON THIS LAYOUT.  
 - THIS LAYOUT IS BASED ON .IES FILES THAT WERE LAB TESTED OR COMPUTER GENERATED. ACTUAL RESULTS MAY VARY.



**CUSTOMER APPROVAL**

Drawing is approved, proceed with production

Drawing is not approved, make changes as noted

Customer Signature \_\_\_\_\_ Date \_\_\_\_\_



**Jim Hahn**

**From:** Jim Hahn  
**Sent:** Wednesday, January 15, 2025 10:40 AM  
**To:** Jim Hahn  
**Subject:** FW: New Quote from 1000Bulbs.com



**Jim Hahn | General Manager**  
o 904.637.0648 | [jhahn@troon.com](mailto:jhahn@troon.com)

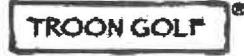

**DISCOVER**  
THE TROON EXPERIENCE



*CORLEAF LEVEL  
1000 BULBS  
COVERS 1+2  
PICKET BALL 2-COURTS  
32 LIGHT TOTAL (S)  
LIGHTS TENNIS RB*

You don't often get email from [nours@1000bulbs.com](mailto:nours@1000bulbs.com). Learn why this is important

**1000Bulbs**<sub>com</sub>

## Sales Proposal

Quote #: 7975840    Date: 01/14/25    Date Quote Written: 01/14/25    Expiration Date: 04/14/25

### Salesperson

Nick Ours  
1475 Republic Pkwy Ste 100  
Mesquite, TX 75150  
[nours@1000bulbs.com](mailto:nours@1000bulbs.com)  
p. 972-543-0561  
f. 972-764-5926

### Bill To

Mark Arrowsmith  
Eagle Landing  
Mark Arrowsmith  
3979 Eagle Landing Pkwy  
Orange Park, FL 32065  
9045346440

### Ship To

Mark Arrowsmith  
Eagle Landing  
Mark Arrowsmith  
3979 Eagle Landing Pkwy  
Orange Park, FL 32065  
9045346440

Qty	Product	Price
32	 <b>HALCO-24907</b> 43,200 Lumens - 300 Watt - 5000 Kelvin - LED Flood Light Fixture - 145 Lumens Per Watt - Replaces a 1000 Watt Metal Halide - Slipfitter Mount - 0-10 Volt Dimmable - 120-277 Volt - Halco 24907	\$385.54
<i>32 x \$385.54</i>		
<i>WE WILL DO INSTALL.</i>		
<b>Subtotal</b>		<b>\$12,337.28</b>
<b>Dropship</b>		<b>\$0.00</b>
<b>Total</b>		<b>\$12,337.28</b>



# ORDER/QUOTE FORM

## TECHLIGHT

INNOVATION IN ILLUMINATION

Quote  Required Field Select One Order

### SALES PERSON

**BEAU SUMMERSILL**  
National Sales Director - Sports Lighting Division

2707 Satsuma Dr. | Dallas, TX 75229  
CELL: 910.358.9775 TOLL: 800.225.0727  
EMAIL: bsummersill@techlight.com

10/07/2024

### CUSTOMER INFO.

NAME	PHONE #	CUSTOMER PD#	CREDIT APPROVED	TERMS
Jim Hahn	904.637.0648	Eagle Retrofit	<input type="radio"/>	<input type="radio"/>
SOLD TO: Eagle Landing		SHIP TO: Eagle Landing 3989 Eagle Landing Pkwy, Orange Park, Florida 32065		
BILL TO: Eagle Landing				
ATTN: Jim		ATTN: Jim		

### FREIGHT OPTIONS

ALLOWED  PREPAID  PP & ADD

QTY	MARK	PART # / DESCRIPTION	UNIT PRICE	TOTAL
8		CTA L C 80L T4T 1 BK	\$ 1,025.00	\$ 8,200.00
8		GALV Custom Adapters	\$ 105.00	\$ 840.00
1		Freight	\$ 275.87	\$ 275.87
			\$ 0.00	\$ 0.00
			\$ 0.00	\$ 0.00
			\$ 0.00	\$ 0.00
			\$ 0.00	\$ 0.00
			\$ 0.00	\$ 0.00
			\$ 0.00	\$ 0.00
			\$ 0.00	\$ 0.00
			\$ 0.00	\$ 0.00
			\$ 0.00	\$ 0.00
			\$ 0.00	\$ 0.00
			\$ 0.00	\$ 0.00
			SUBTOTAL	\$ 9,315.87
			FREIGHT	\$ 0.00
			TAX	\$ 0.00
			TOTAL	\$ 9,315.87

*TOP OF LINE  
TECH LIGHT!*

*IF we DO  
CURTS 1+2  
BOTH Metal Bell  
CURTS*

*4-CURTS TOTAL  
ABOUT \$32K*

Required Field:  
30 Days

ORDER/QUOTE EXPIRATION TIMEFRAME (DAYS):

## Jim Hahn

---

**From:** Beau Summersill <bsummersill@techlight.com>  
**Sent:** Monday, October 7, 2024 12:00 PM  
**To:** Jim Hahn; Scott Swenson  
**Subject:** [EXTERNAL] RE: Techlight  
**Attachments:** nitkowski-b 8 pole 8 CTA.pdf; CA 132596 4 inch Round Adapter.pdf; CA 13189-SSA-LSI COURTSIDER ADPTR.PDF; Eagle Retrofit 10.7.24.pdf; New Account Application No Terms.pdf; USTA TENNIS.PB Light Requirements .pdf

GM Jim,

I hope you and yours are going to be safe through this storm.... Sending positive prayers your way...

I wanted to send this over after our discussion on Friday. The fixture I want to present you with is our New Court Ace fixture( CTA L). As mentioned on our call, you will get your club into Class III lighting of 50+ fc avg and a max/min under 2. Based on the sample study attached, you will achieve a 59.9 FC avg and a tight 1.74 max/min with our 80,000 lumen CTA L tennis fixture.

The mounting is TBD but I would recommend the 4" sleeve adapter that you would need to cut the square plate off the end to slide this over. You can also get the bolt pattern, and we can match up the bolts with a plate like the other option attached( SSA-LSI).

We are offering you 20 days to test out our 8- Court Ace Series fixtures to light your court. All we ask is that you pay for the shipping to get the fixtures and the custom adapters. I forgot that we would have to build these custom adapters and would not be able to sell them in the future if you were to return the demo opportunity..

We would ask for Net 30 terms if you decided to purchase the fixtures or ship back the fixtures within 30 days.



# Tennis Lighting

## Recommended Illumination for Tennis Facilities

Recommended Horizontal Illumination			
Performance Criteria	Class I	Class II	Class III
Average Maintained Horizontal Foot-candles within PPA (1,2,4)	125+ (1250 lux)	75 (750 lux)	50 (500 lux)
Minimum Maintained Horizontal Foot-candles within PPA (2,4)	100 (1000 lux)	60 (600 lux)	40 (400 lux)
Maximum Uniformity Ratio (3)	1.5	1.7	2.0

Recommended Vertical Illumination			
Performance Criteria	Class I	Class II	Class III
Average Maintained Vertical Foot-candles within PPA (1,2,4)	50 (500 lux)	30 (300 lux)	20 (200 lux)
Maximum Uniformity Ratio (3)	2.0	3.0	3.0

### Notes:

- Maintained foot-candles is determined by applying a light loss factor (LLF) to the initial or measured foot-candles. LLF is dependent on fixture type, fixture maintenance and atmospheric conditions. It can vary between .60 and .90. Consult fixture manufacturer for proper LLF values.
- Average maintained and minimum maintained foot-candles should be calculated within the Primary Playing Area (PPA) with the foot-candle values multiplied by the appropriate LLF.
- Uniformity ratio is defined as the ratio of the maximum foot-candles divided by the minimum foot-candles.
- Primary Playing Area (PPA) is defined as the area that includes 6' beyond the sidelines and 10' behind the baseline.

Typical Facility Classifications		
Class I (1)	Class II	Class III
Professional	Satellite (3)	College (4)
International	Challenger (3)	High School
Satellite	College (2)	Tennis Clubs
Challenger	Tennis Clubs	Parks/Recreational
College	Parks/Recreational	Residential
	Residential	

### Notes:

- Class I facilities generally involve broadcast quality television production. These facilities will include permanent spectator accommodations.
- Facilities which host intercollegiate play, but without broadcast television requirements. These facilities may have permanent or temporary seating.
- Professional tennis events without broadcast television requirements.
- Collegiate facilities primarily used for practice or for intramural or recreational play.

Please note that some facility types appear in multiple categories. Illumination levels for a specific facility should be chosen based on the highest skill level, or spectator and television requirements that will take place at the facility. See the descriptions for more detailed information about each class. It is recognized that older players require higher light levels. Facilities with older average player ages should be designed for higher levels of light.



ZONE		REV.	DESCRIPTION	DATE	APPROVED
4	3				

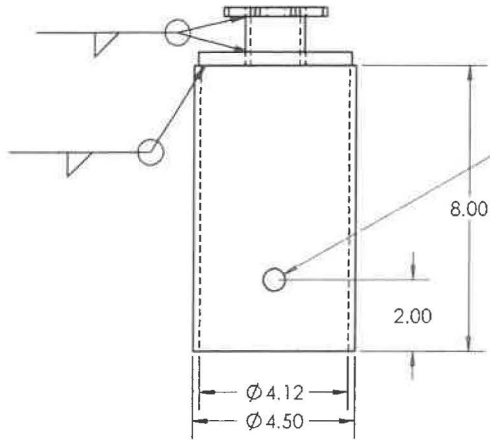
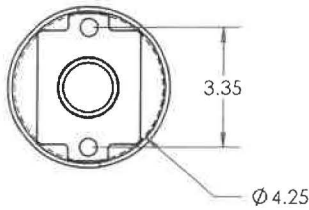

Ø .63 THRU  
FIELD DRILL & THRU BOLT  
BOLTS PROVIDED BY OTHERS

**CUSTOMER APPROVAL**

Drawing is approved, proceed with production

Drawing is not approved, make changes as noted

---

Customer Signature \_\_\_\_\_ Date \_\_\_\_\_

Custom products require the execution of a Techlight NCNR (Non-Cancellable/Non-Returnable) Product Agreement for order processing

ITEM NO.	PART NUMBER	DESCRIPTION	QTY.
1	132596P	4.50OD X .188 TUBE	1
2	132596PLT	PLATE 4.25"RD X 1.69ID X .375 THK	1
3	PDV90TP	PIPE STL 1-1/4 SCH40X1-5/8 CUT	1
4	P2AFPLT	SSA PATTERN FOR 2AF	1

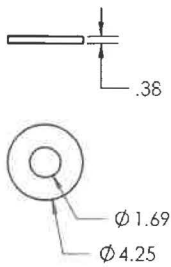

DESIGN	DATE
PRM	2.26.24
DRAWN	DATE
PRM	2.26.24
CHECKED	DATE
APPROVED	DATE

**SOLIDWORKS DRAWING**  
UNLESS OTHERWISE SPECIFIED  
DIMENSIONS ARE IN INCHES

DECIMALS: XX = ±0.050, XXX = ±0.010, XXXX = ±0.005, XXXXX = ±0.0025, FRACTION: 1/32

ANGLE: XX = ±1.0°, XXX = ±0.5°

SURFACE: 125/ FINISH

MATERIAL #: \_\_\_\_\_  
MATERIAL: \_\_\_\_\_  
MATERIAL SIZE: \_\_\_\_\_

**TECHLIGHT®**  
WWW.TECHLIGHT.COM

DESCRIPTION: 132596 SLIPOVER 5"RD SSA ADAPTER

THE INFORMATION CONTAINED IN THIS DRAWING IS THE SOLE PROPERTY OF TECHLIGHT USA. ANY REPRODUCTION IN PART OR WHOLE WITHOUT THE WRITTEN PERMISSION OF TECHLIGHT USA IS PROHIBITED.

MASS PROPERTIES	SURFACE AREA	VOLUME	WEIGHT
DENSITY	sq.in.	sq.in.	cu.in.
AMOUNT OF PAINT	lbs/cu.in.	PART NO.	132596
DO NOT SCALE DRAWING	SCALE 1:4	CAD FILE	132596

SHEET 1 OF 1

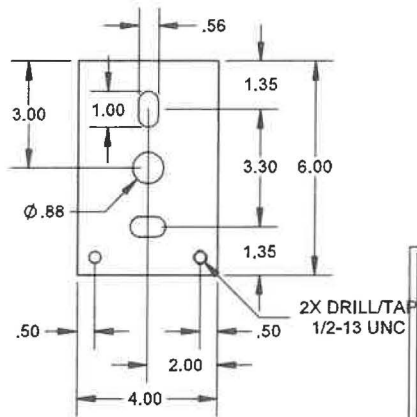
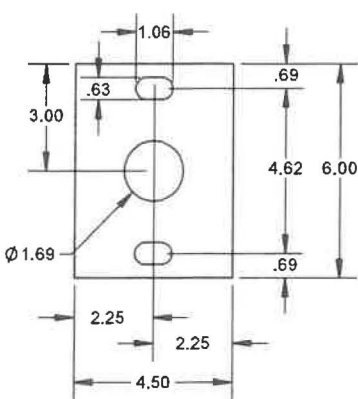
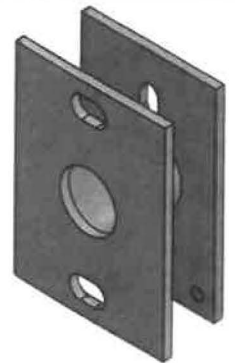
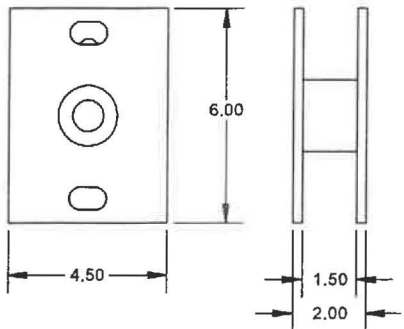

**CUSTOMER APPROVAL**

Drawing is approved, proceed with production.

Drawing is not approved, make changes as noted.

\_\_\_\_\_ Date \_\_\_\_\_

Customer Signature

**PROPRIETARY AND CONFIDENTIAL**  
 ALL INFORMATION CONTAINED  
 HEREIN IS UNCLASSIFIED  
 EXCEPT WHERE SHOWN  
 OTHERWISE BY A CONTROL  
 NUMBER.

REV		DATE		TECHLIGHTUSA.COM
1	PRM	12.20.17		
2X DRILL/TAP 1/2-13 UNC				
MATERIAL <b>STEEL</b>				SSA-LSI COURTSIDER ADPTR 13189
FINISH				
PART NO.				
A	13189			REV

*B.*

# T&M ELECTRIC OF CLAY COUNTY, LLC.

200 College Dr.  
Orange Park, Florida 32065  
State License #EC0001152  
FEIN 59-2052695

Phone: (904) 272-0272

Fax: (904) 276-7689

January 23, 2025

**Proposal Submitted To:**

Scott Swenson

**Job Location:**

3989 Eagle Landing Parkway Orange Park, FL. 32065

Mrs. Swenson,

Thank you for allowing us to provide you with a quote for the electrical service work at 3989 Eagle Landing Parkway. If you have any questions, please feel free to contact me and thank you again for entrusting T&M Electric with your electrical needs.

1. Provide and install (1) matching Sternberg pole light.

\$16,195.00

Price excludes replace or repairs to pole base.

Sincerely,

Thank you,

Jason Bush

T & M Electric of Clay County, LLC.

200 College Drive

Orange Park, FL 32065

Phone (904) 272-0272

[jason@tmelectricinc.com](mailto:jason@tmelectricinc.com)

Project Name \_\_\_\_\_ Qty \_\_\_\_\_  
 Type \_\_\_\_\_ Catalog / Part Number \_\_\_\_\_



1930LED

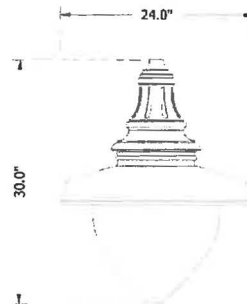

1930LED-RLM24

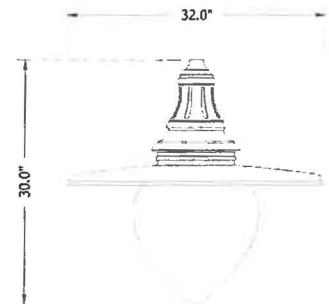

1930LED-RLM32

**Distribution Type**

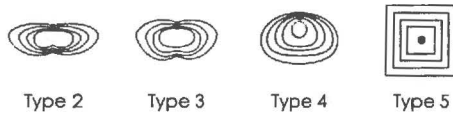

**Description**

The 1930LED series is a large scale decorative pendant luminaire which consists of a decorative cast aluminum fitter, and optional heavy gauge spun aluminum shade with integral lens frame. The optical enclosure is sealed against moisture and dust penetration.

**CCT - Color Temp (K)**

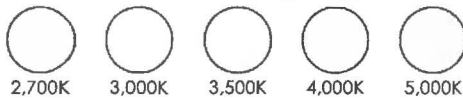

**1930LED** - EPA: .96 (ft²) | WEIGHT: 30 LBS  
**1930LED-RLM24** - EPA: 1.08 (ft²) | WEIGHT: 37 LBS  
**1930LED-RLM32** - EPA: 1.09 (ft²) | WEIGHT: 40 LBS

**Features**

**7 Year Warranty**



**Mounting Configuration**

- 1W:** Wall Mount
- 2A:** 2 Arm Mount @ 180°
- 3A:** 3 Arms @ 120°
- 4A:** 4 Arms @ 90°
- 2AM:** 2 Arm Mid-Mount @180°
- CAT:** Catenary
- 1A:** 1 Arm Mount
- 2A90:** 2 Arm Mount @ 90°
- 3A90:** 3 Arms @ 90°
- 1AM:** 1 Arm Mid-Mount
- SH44:** Stem Hung
- CH44:** Chain Hung

**IP Rating**



**Optional Control Receptacle**

**R7:** 7-Pin control receptacle only

**Optional Control**

- PE:** Twist-Lock Photocontrol (120V-277V)
- PE4:** Twist-Lock Photocontrol (347V-480V)
- SC:** Shorting Cap
- PEC:** Electronic Button Photocontrol (120V-277V)
- PEC4:** Electronic Button Photocontrol (480V)

**Certifications**



**Optional Fuse**

**FHD:** Double Fuse and Holder

**Optional Hangstraight**

- HSHS:** Standard Horizontal Hangstraight, Spike Finial
- HSHN:** Standard Horizontal Hangstraight, No Finial
- HSHB:** Standard Horizontal Hangstraight, Ball Finial
- EZ:** Vertical Hangstraight, Large, "EZ" Mount

**Optional House Side Shield**

**HSS:** 120° House Side Shield

**Optional Fixed Dimming Resistor Board**

**FDRB:** Fixed Dimming Resistor Board

<b>Hardware</b>	Includes Stainless steel hardware. Most finishes will include hardware with a Black Oxide conversion coating. Light finishes will get non-color coated hardware ( <b>Whites and Silvers</b> )
<b>Lens</b>	Clear textured acorn offered in impact resistant DR acrylic or UV stabilized polycarbonate material. An injection molding process adds a textured surface for glare mitigation.
<b>UL Listing</b>	UL listed per UL1598 and CSA 22.2 No. 250.0 for the United States and Canada. Suitable for Wet Locations.
<b>Electronic Driver</b>	The LED driver is UL recognized and will be securely mounted inside the fixture, for optimized performance and longevity. It will be supplied with a quick-disconnect electrical connector on the power supply, providing easy power connections for fixture installation and maintenance. It will have DC voltage output and be a constant current design. It runs at 50/60HZ and will have overload, overheat, and short circuit protection. It will be supplied with a supplemental line-ground, line-neutral and neutral-ground electrical surge protection in accordance with IEEE/ANSI C62.41.2 guidelines. It will be a high efficiency driver with a THD less than 20% and a high-power factor greater than .9. It will be dimming capable using a 0-10V signal, consult factory for more information.
<b>IP Rating</b>	IP66 rated luminaire for enhanced protection against dust and water intrusion.
<b>Finish</b>	Our 6 Stage Polyester Powder coat paint system offers a beautiful high-end finish that holds up to even the most extreme environments. Each part is inspected for quality and consistency before being released for shipment. Our system exceeds AAMA 2604, AAMA 2605, ASTM D523 and ASTM D4214 requirements.
<b>Traditional Finish</b>	Traditional paint finishes are available in Sternberg Lighting's Traditional product line. A range of colors help accent the decorative elements on the product. Finishes are available in textured or smooth. Available finishes include: <b>Black, White, Park Green, Architectural Medium Bronze and Dark Bronze</b>
<b>Sternberg Select Finish</b>	The Sternberg Select antique-inspired palette adds a touch of vintage elegance to modern applications. <b>Old World Gray Textured</b> is a 1 part powder coat with metallic flakes. <b>Verde Green and Swedish Iron</b> is a 2 part finish that includes a powder coat base coat with a hand applied antique top coat. The top coat is unique to each application and changes over time.
<b>Custom Finish</b>	Custom finishes are offered to adapt to any application. <b>Rust, Weathered Brown and Cedar</b> are special 1 part powder coat finishes with a distinctive look. <b>Old Iron and Weathered Black</b> are 2 part finishes that includes a powder coat base coat with a hand applied antique top coat. The top coat is unique to each application and changes over time. <b>Two-Tone and Custom Match</b> options are available to blend sternberg product with the site, consult factory for more information.
<b>Warranty</b>	7-year limited warranty. See Website for Terms and Conditions.
<b>LEDs</b>	The luminaire shall use high output, high brightness LED's, consisting of a two piece assembly complete with Chip on Board (COB) LED component and COB holder frame. The LEDs shall be 100% recyclable; not contain lead, mercury or any other hazardous substances and shall be RoHS compliant. Lumen maintenance shall be determined in accordance with IESNA TM-21, based on LED manufacturer LM-80 test data of no less than 6,000 hours and in-situ testing of the luminaire by an NVLAP accredited Energy Efficient Lighting Products lab. The high-performance white LEDs will have a predicted lumen depreciation of approximately 100,000 hours with greater than 70% of initial output at 25°C. The High Brightness, High Output LED's shall be 4000K (2700K, 3000K, 3500K or 5000K option) correlated color temperature (CCT) with a 70 (minimum) color rendering index (CRI). Consult factory for custom color CCT. The luminaire shall have a minimum _____ (see table) delivered initial lumen rating when operated at steady state with an average ambient temperature of 25°C (77°F). <b>CCT Lumen Derate Values from 4,000K</b> 2,700K (80+ CRI)=.89 3,000K (70+ CRI)=.97 3,500K (80+ CRI)=.93 5,000K (70+ CRI)=1.01 The LED's in this system will be fully shielded in a direct downward position to maximize efficiency.
<b>Optics</b>	The luminaire shall be provided with individual, refractor type optics applied to each LED. The luminaire shall provide Type ____ (2, 3, 4 or 5) light distribution per the IESNA classifications. Testing shall be done in accordance with IESNA LM-79.
<b>Backlight Optical Control</b>	<b>Internal House Side Shield (HSS):</b> An optional <b>INTERNAL</b> 120° House Side Shield helps control backlight. Spun aluminum panel painted to match fixture.

**Hangstraight**

Horizontal Hang-straight's slip fit 4" long by 2-3/8" OD on horizontal tenon



Standard Horizontal Hangstraight, Spike Finial (**HSHS**)



Standard Horizontal Hangstraight, Ball Finial (**HSHB**)



Standard Horizontal Hangstraight, No Finial (**HSHN**)



"EZ" Vertical hangstraight (**EZ**)

**Options**



NEMA Twist-Lock Photocell (**PE or PE4**)



Fixed Dimming Resistor Board (**FDRB**)



Button Photocell (**PEC**)



7-Pin NEMA Twist-Lock Receptacle (**R7**)



Double Fuse Holder & (2) 3A Fuses (**FHD**)

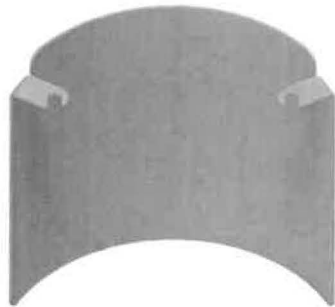

House Side Shield (**HSS**)

How to Order

Mounting Configuration	Overall Drop Length (In Inches) <sup>(2) (3)</sup>	Fixture	Shade <sup>(4)</sup>	LED	CCT - Color Temp (K)	Distribution Type	Driver	Lens
<b>1W</b> Wall Mount  <b>1A</b> 1 Arm Mount  <b>2A</b> 2 Arm Mount @ 180°  <b>2A90</b> 2 Arm Mount @ 90°  <b>3A</b> 3 Arms @ 120°  <b>3A90</b> 3 Arms @ 90°  <b>4A</b> 4 Arms @ 90°  <b>1AM</b> 1 Arm Mid-Mount  <b>2AM</b> 2 Arm Mid-Mount @180°  <b>SH44</b> Stem Hung  <b>CH44</b> Chain Hung  <b>CAT</b> Catenary <sup>(1)</sup>		<b>1930LED</b> Acorn, Large	<b>RLM24</b> 24" RLM Shade, Park Ridge  <b>RLM32</b> 32" RLM Shade, Park Ridge	<b>1L</b> 1 LED  <b>2L</b> 2 LEDs	<b>27</b> 2,700K  <b>30</b> 3,000K  <b>35</b> 3,500K  <b>40</b> 4,000K  <b>50</b> 5,000K	<b>T2</b> Type 2  <b>T3</b> Type 3  <b>T4</b> Type 4  <b>T5</b> Type 5	<b>MDL06</b> 120V-277V, 600mA <sup>(5)</sup>  <b>MDH06</b> 347V-480V, 600mA <sup>(5)</sup>  <b>MDL08</b> 120V-277V, 800mA <sup>(5)</sup>  <b>MDH08</b> 347V-480V, 800mA <sup>(4)</sup>  <b>MDL09</b> 120V-277V, 900mA <sup>(5)</sup>  <b>MDH09</b> 347V-480V, 900mA <sup>(5)</sup>  <b>MDL10</b> 120V-277V, 1000mA <sup>(4)</sup>  <b>MDH10</b> 347V-480V, 1000mA <sup>(4)</sup>  <b>MDL12</b> 120V-277V, 1200mA  <b>MDH12</b> 347V-480V, 1200mA	<b>A</b> Acrylic Clear Teardrop  <b>P</b> Poly Clear Teardrop

Notes:

- 1. Requires EZ hang-straight.
- 2. Required field for Stem or Chain Mounting Configuration.
- 3. Minimum 37" Overall Drop Length.

- 4. Shade is optional
- 5. For 1L only.
- 6. For 2L only.



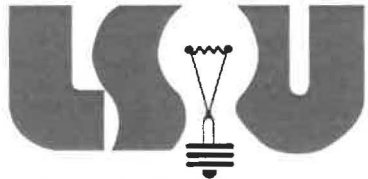

**LAMP SALES UNLIMITED, INC.**

Quoted For: T&M  
Orange Park, FL

# Quote

**Job Name:** Eagle Landing Light Pole Repair  
**Quote #:** 25-57143-0  
**Job Location:** Orange Park, Florida  
**Issue Date:** 1/21/2025  
**Good Through:** 2/20/2025  
**Quoted By:**

Type	Qty	Manufacturer / Brand	Catalog #	Line Comment	Unit \$	Ext \$
	1	Sternberg Lighting	2A-1930LED-1L35T3-MDL12-A-HSHS/CA6/9220ARTF-16FF-RPBP-DSPA-DIS/BK	SIMILAR TO PREVIOUS ORDER 52839 (2005) LED IN LIEU OF HID PLANTER ARMS IN LIEU OF BASKET		
<b>Subtotal</b>						
	1	Sternberg Lighting	2A-1930-175MHP-240-MED-RE3-A/CA6/9220ARTF-16FF-RPBP-DSPA-DIS/BK	SIMILAR TO PREVIOUS ORDER 52839 (2005) PLEASE CONFIRM VOLTAGE PLANTER ARMS IN LIEU OF BASKET		
<b>Subtotal</b>						

**Notes**

- \* All orders must have quotation number referenced
- \* All Finishes Quoted Factory Standards. Verify finishes before ordering.
- \* Verify counts and voltages before ordering.

*SEVENTH ORDER OF BUSINESS*

**REQUISITION FORM**

**SVCDD- Series 2016 -AI/2  
CONSTRUCTION FUND**

The undersigned, an Authorized Officer of South Village Community Development District (the "District") hereby submits the following requisition for disbursement under and pursuant to the terms of the Master Trust Indenture from the District to U.S. Bank National Association, Orlando, Florida, as trustee (the "Trustee"), dated as of January 1, 2005 (the "Master Indenture"), as amended and supplemented by the Second and Third Supplemental Indenture from the District to the Trustee, dated as of June 1, 2016 (the Master Indenture as amended and supplemented is hereinafter referred to as the "Indenture") (all capitalized terms used herein shall have the meaning ascribed to such term in the Indenture):

- (A) Requisition No.: 084**
- (B) Payee: South Village CDD**
- (C) Amount Payable: \$9,410.00**
- (D) Invoice: Inv. 191933 - \$1,210 (Laurel Valley Signage Review, Prep Monument Sign Details)  
Inv. 192125 - \$4,495 (Laurel Valley Signage Review, Prepare Monument sign Details)  
Inv. 192310 - \$2,300 (Laurel Valley Entrance Signage)  
Inv. 192399 - \$1,405 (Final Closeout, Landscape Site Inspection)  
(Reimbursement to South Village from 2016 construction fund for above)**
- (E) Series 2016-AI/2 CONSTRUCTION FUND**

The undersigned hereby certifies that obligations in the stated amount set forth above have been incurred by the District, that each disbursement set forth above is a proper charge against the Districtwide Acquisition and Construction Account and the subaccount, if any, referenced above, that each disbursement set forth above was incurred in connection with the acquisition and construction of the Districtwide Project and each represents a Cost of the Districtwide Project, and has not previously been paid.

The undersigned hereby further certifies that there has not been filed with or served upon the District notice of any lien, right to lien, or attachment upon, or claim affecting the right to receive payment of, any of the moneys payable to the Payee set forth above, which has not been released or will not be released simultaneously with the payment hereof.

The undersigned hereby further certifies that such requisition contains no item representing payment on account of any retained percentage which the District is at the date of such certificate entitled to retain.

If this requisition is for a disbursement from other than the Costs of Issuance Account or for payment of capitalized interest, there shall be attached a resolution of the Governing Body of the District approving this requisition or the approving the specific contract with respect to which disbursements pursuant to this requisition are due and payable.

Attached hereto are originals of the invoice(s) from the vendor of the property acquired or services rendered with respect to which disbursement is hereby requested

**SOUTH VILLAGE COMMUNITY  
DEVELOPMENT DISTRICT**

By: \_\_\_\_\_



Authorized Officer

**CONSULTING ENGINEER'S APPROVAL FOR NON-COST OF ISSUANCE AND  
CAPITALIZED INTEREST REQUESTS ONLY**

If this requisition is for a disbursement from other than Capitalized Interest or Costs of Issuance, the undersigned Consulting Engineer hereby certifies that this disbursement is for a Cost of the Districtwide Project and is consistent with: (i) the applicable acquisition or construction contract; (ii) the plans and specifications for the portion of the Districtwide Project with respect to which such disbursement is being made; and, (ii) the report of the Consulting Engineer attached as an Exhibit to the Second and Third Supplemental Indenture, as such report shall have been amended or modified on the date hereof.

Alex R. Acree



Consulting Engineer

Project Manager Alex Acree

GMS, LLC  
Marilee Giles  
475 West Town Place Suite 114  
St. Augustine, FL 32092



Engineering - Architecture - Planning - Surveying

October 04, 2024  
Invoice # 191933

Project 0000021416.0000 South Village CDD District Engineer

This invoice includes charges for tasks performed for your project, including:

- CDD Conference Call and Meeting
- Laurel Valley Signage Review
- Prepare Monument Sign Details

Please call Alex Acree if you have any questions or concerns regarding your project.  
For billing inquiries, please contact our Accounting Department.

**Professional Services through September 30, 2024**

Phase 0001 Engineering Services

	<b>Hours</b>	<b>Rate</b>	<b>Amount</b>
Sr. Project Manager	1.75	175.00	306.25
Sr. Landscape Architect	2.00	160.00	320.00
Sr. CAD Designer	7.00	125.00	875.00
Project Support	.25	60.00	15.00
<b>Total Labor</b>			<b>1,516.25</b>

**Total Due:** 1,516.25

**Billed to Date**

	<b>Current Due</b>	<b>Prior Billed</b>	<b>Billed to Date</b>
Labor	1,516.25	28,281.25	29,797.50
Expense	0.00	583.80	583.80
Unit	0.00	57.97	57.97
<b>Totals</b>	<b>1,516.25</b>	<b>28,923.02</b>	<b>30,439.27</b>

Project Manager Alex Acree

Governmental Management Services  
Marilee Giles  
475 West Town Place Suite 114  
St. Augustine, FL 32092



Engineering - Architecture - Planning - Surveying

November 08, 2024  
Invoice # 192125

Project 0000021416.0000 South Village CDD District Engineer

This invoice includes charges for tasks performed for your project, including:

- CDD Conference Call and Meeting
- Laurel Valley Signage Review
- Prepare Monument Sign Details

Please call Alex Acree if you have any questions or concerns regarding your project.  
For billing inquiries, please contact our Accounting Department.

**Professional Services through October 31, 2024**

Phase 0001 Engineering Services

	Hours	Rate	Amount
Sr. Project Manager	3.00	175.00	525.00
Sr. Planner	.50	160.00	80.00
Sr. Landscape Architect	4.75	160.00	760.00
Sr. CAD Designer	29.00	125.00	3,625.00
Project Support	.50	60.00	30.00
<b>Total Labor</b>			<b>5,020.00</b>

**Total Due: 5,020.00**

**Billed to Date**

	Current Due	Prior Billed	Billed to Date
Labor	5,020.00	29,797.50	34,817.50
Expense	0.00	583.80	583.80
Unit	0.00	57.97	57.97
<b>Totals</b>	<b>5,020.00</b>	<b>30,439.27</b>	<b>35,459.27</b>

Project Manager Alex Acree

Governmental Management Services  
Marilee Giles  
475 West Town Place Suite 114  
St. Augustine, FL 32092



December 10, 2024  
Invoice # 192399

Project 0000021416.0000 South Village CDD District Engineer

This invoice includes charges for tasks performed for your project, including:

- CDD Conference Call and Meeting
- Final Close Out
- Landscape Site Inspection

Please call Alex Acree if you have any questions or concerns regarding your project. For billing inquiries, please contact our Accounting Department.

**Professional Services through November 30, 2024**

Phase 0001 Engineering Services

	Hours	Rate	Amount	
Sr. Project Manager	2.50	175.00	437.50	
Sr. Landscape Architect	4.00	160.00	640.00	
Sr. CAD Designer	6.00	125.00	750.00	
Project Support	.25	60.00	15.00	
<b>Total Labor</b>				<b>1,842.50</b>
				<b>Total Due: 1,842.50</b>

**Billed to Date**

	Current Due	Prior Billed	Billed to Date
Labor	1,842.50	34,817.50	36,660.00
Expense	0.00	583.80	583.80
Unit	0.00	57.97	57.97
<b>Totals</b>	<b>1,842.50</b>	<b>35,459.27</b>	<b>37,301.77</b>



Project Manager Alex Acree

Governmental Management Services  
Marilee Giles  
475 West Town Place Suite 114  
St. Augustine, FL 32092



Engineering - Architecture - Planning - Surveying

December 09, 2024  
Invoice # 192310

Project 0000021416.0001 South Village CDD District Engineer

This invoice includes charges for tasks performed for your project, including:

- Laurel Valley Entrance Signage Structural Design

Please call Alex Acree if you have any questions or concerns regarding your project.

For billing inquiries, please contact our Accounting Department.

**Professional Services through November 30, 2024**

Phase	0003	Eagle Landing Monument Sign		
<b>Fee</b>				
Total Fee		2,300.00		
Percent Complete	100.00	Total Earned	2,300.00	
		Previous Fee Billing	0.00	
		Current Fee Billing	2,300.00	
		<b>Total Fee</b>		<b>2,300.00</b>
		<b>Total Due:</b>		<b>2,300.00</b>

**Billed to Date**

	Current Due	Prior Billed	Billed to Date
Fee	2,300.00	0.00	2,300.00
Labor	0.00	10,277.50	10,277.50
Unit	0.00	13.88	13.88
<b>Totals</b>	<b>2,300.00</b>	<b>10,291.38</b>	<b>12,591.38</b>



## REQUISITION FORM

### SVCDD- Series 2016 -A1/2 CONSTRUCTION FUND

The undersigned, an Authorized Officer of South Village Community Development District (the "District") hereby submits the following requisition for disbursement under and pursuant to the terms of the Master Trust Indenture from the District to U.S. Bank National Association, Orlando, Florida, as trustee (the "Trustee"), dated as of January 1, 2005 (the "Master Indenture"), as amended and supplemented by the Second and Third Supplemental Indenture from the District to the Trustee, dated as of June 1, 2016 (the Master Indenture as amended and supplemented is hereinafter referred to as the "Indenture") (all capitalized terms used herein shall have the meaning ascribed to such term in the Indenture):

- (A) **Requisition No.:** 085
- (B) **Payee:** Matthews | DCCM  
7 Waldo Street  
St. Augustine, FL 32084
- (C) **Amount Payable:** \$347.50
- (D) **Invoice:** 192613 - (Sign Design and coordination)
- (E) **Series 2016-A1/2 CONSTRUCTION FUND**

The undersigned hereby certifies that obligations in the stated amount set forth above have been incurred by the District, that each disbursement set forth above is a proper charge against the Districtwide Acquisition and Construction Account and the subaccount, if any, referenced above, that each disbursement set forth above was incurred in connection with the acquisition and construction of the Districtwide Project and each represents a Cost of the Districtwide Project, and has not previously been paid.

The undersigned hereby further certifies that there has not been filed with or served upon the District notice of any lien, right to lien, or attachment upon, or claim affecting the right to receive payment of, any of the moneys payable to the Payee set forth above, which has not been released or will not be released simultaneously with the payment hereof.

The undersigned hereby further certifies that such requisition contains no item representing payment on account of any retained percentage which the District is at the date of such certificate entitled to retain.

If this requisition is for a disbursement from other than the Costs of Issuance Account or for payment of capitalized interest, there shall be attached a resolution of the Governing Body of the District approving this requisition or the approving the specific contract with respect to which disbursements pursuant to this requisition are due and payable.

Attached hereto are originals of the invoice(s) from the vendor of the property acquired or services rendered with respect to which disbursement is hereby requested

**SOUTH VILLAGE COMMUNITY  
DEVELOPMENT DISTRICT**

**By:**



Authorized Officer

**CONSULTING ENGINEER'S APPROVAL FOR NON-COST OF ISSUANCE AND  
CAPITALIZED INTEREST REQUESTS ONLY**

If this requisition is for a disbursement from other than Capitalized Interest or Costs of Issuance, the undersigned Consulting Engineer hereby certifies that this disbursement is for a Cost of the Districtwide Project and is consistent with: (i) the applicable acquisition or construction contract; (ii) the plans and specifications for the portion of the Districtwide Project with respect to which such disbursement is being made; and, (ii) the report of the Consulting Engineer attached as an Exhibit to the Second and Third Supplemental Indenture, as such report shall have been amended or modified on the date hereof.

Alex R. Acree



Consulting Engineer

Project Manager Alex Acree

Matthews | **DCCM**

Engineering - Architecture - Planning - Surveying

February 07, 2025

Invoice # 192613

Governmental Management Services  
Marilee Giles  
475 West Town Place Suite 114  
St. Augustine, FL 32092

Project 0000021416.0000 South Village CDD District Engineer

This invoice includes charges for tasks performed for your project, including:

- CDD Coordination
- Additional Monument Sign Revisions
- CDD Meeting and Agenda Call

Please call Alex Acree if you have any questions or concerns regarding your project.  
For billing inquiries, please contact our Accounting Department.

**Professional Services through January 31, 2025**

Phase 0001 Engineering Services

	Hours	Rate	Amount	
Sr. Project Manager	1.50	175.00	262.50	
Sr. Landscape Architect	1.00	160.00	160.00	
Sr. CAD Designer	1.50	125.00	187.50	
Project Support	.50	60.00	30.00	
<b>Total Labor</b>				<b>640.00</b>
				<b>Total Due: 640.00</b>
				<b>Monument Sign 347.50</b>

**Outstanding Invoices**

Number	Date	Balance
192490	1/13/2025	2,156.25
<b>Total</b>		<b>2,156.25</b>

**Billed to Date**

	Current Due	Prior Billed	Billed to Date
Labor	640.00	38,816.25	39,456.25
Expense	0.00	583.80	583.80
Unit	0.00	57.97	57.97
<b>Totals</b>	<b>640.00</b>	<b>39,458.02</b>	<b>40,098.02</b>

*EIGHTH ORDER OF BUSINESS*

*A.*

# South Village Community Development District Operations Report

Date: February 2025  
To: SVCDD, BOARD OF SUPERVISORS  
From: General Manager, Golf, F&B, Rec Facilities, Maintenance, and Community  
Re: Monthly Operations Report

## Aquatic Center/Kids Club/Café:

- a. Putt Putt pond and water falls is in good condition
- b. Frog fountain was cleaned again and all frogs hoses were inspected and fixed
- c. Pressure washing areas around the pool area and Cabana Bar continue
- d. Repaired Kid's Club doors (weren't locking properly)
- e. Paver work completed on poll deck area a few spots.

## Athletic Center:

- a. Touch-up painted the fitness center, painted storage areas, doors all location
- b. Placed hooks in bathrooms for patron's belongings
- c. Created toiletry baskets for bathrooms
- d. Replaced neck pad for Smith machine
- e. Re-labeled weights
- f. Ordered more wipe holders for upstairs gym
- g. Moved drink coolers into pro shop
- h. Ordered more apparel and accessories for pro shop – they are en route
- i. Touch-up painted the fitness center bathrooms
- j. Sent out department surveys for all facilities and sub-departments
- k. Books & Banter on 2/12. We discussed "All the Colors of the Dark" by Chris Whitaker
- l. 8 new resident orientation meetings in February
- m. 4 facility rentals in February

## Community Activities/Communications

- a. Facebook – 5 new likes in February, 12 new followers  
Current followers: 4,176  
12 total posts for February  
Post Reach: 8,485 | Post Engagement: 2,745
- b. Instagram –3 new followers  
1 total posts for February



- c. Website/App Summary 1/22-2/21:  
App Usage (Members) 1,271 logins  
Website Hits – Members 1,677 / Public 10,990
- d. App Downloads – New Devices: 9
- e. Email Summary  
Current number of residents receiving blast: (2/18 What's Happening This Week in Eagle Landing): 2,576  
Open rate of last blast: 48.71%
- f. Text Program: 6 messages sent in February  
273 users signed up

### **Tennis/Pickleball:**

- a. After school tennis programs continue
- b. Staff resurfaced all the tennis courts
- c. Continue to maintain surfaces on several courts
- d. Pickleball programs offered in February and continue to grow
- e. A monthly Pickle ball mixers offered and well attended
- f. Gate was moved and court work also completed
- g. Looking at light replacement for tennis/pickle ball courts, working with Supervisor Osbeck

### **Golf Operations:**

- a. February member/public rounds to date 3,238.
- b. Range sales totaled \$4,905 with 691 users.
- c. Sales in golf shop totaling \$9,894.
- d. Residents continue participating in the weekly complimentary clinics.
- e. Couple's Championship on 15 February: Congratulations to Josh and Shena Roper
- f. Tournament upcoming on March 14th: Glow Golf  
\*Member Only Event\*  
Full field
- g. Tournament upcoming on March 29 & 30  
Match Play  
\*Member Only Event\*
- i. Audit of 2020 to 2023 memberships complete
- j. Retraining of starters and staff on scripts, interaction, attentiveness and better communication with customers has been our number 1 priority. Customers should see an improvement. We ask if you identify a questionable occurrence, to please share, that immediately with Ernie.

### **Clubhouse F&B:**

- a. February weather continues to create challenges with a slower golf play impacting lunch business, but should be near or at the budget target by months end
- b. We were able to conduct a few private events along with our Live Music, and established resident based events, such as Trivia, Live Music, and Karaoke.
- c. The Valentines Dinner garnered rave reviews, as well as the Couples Championship.

- d. We have continued the redevelopment the menu, and you will the menu roll out in phases. The first phase (appetizers) were out the first week of February, with much positive feedback. The second phase (new salads/flatbreads etc.) rolled in week 3, with great feedback as well. Continued revamping of the menu will include the Burger choice adjustment, along with new desserts and so on. We hope to be able to return to dinner menus, and additional dinner nights similar to the valentine's event with the additional funds.
- e. Our new service manager Mike Andrade has begun his transition into his service manager position. And has already begun to make a positive impact on service
- f. Labor is a continued focus, and both front of house and back of house especially during the slower 2<sup>nd</sup> quarter
- g. Looking forward to warmer weather and a busy and successful spring golf season.

### **Golf Course Maintenance:**

- All putting surfaces needle tined and top-dressed
- Wall to wall pre-emergent application completed
- Wall to wall mole cricket application completed
- Irrigation audit for greens and perimeters completed. Tees and fairways to follow immediately
- Quotes being prepared for pump-house repairs and irrigation upgrades
- Warm weather has allowed for new growth to begin across the property
- Updated fertility program for putting surfaces proving to be effective
- Department remains fully staffed as we approach the spring season
- Quarterly soil samples show positive signs for health and resilience moving forward
- Nematode assay shows controllable levels with treatments in yearly agronomic plan.
- 2.7 inches of rainfall.
- One cold weather delay

### **Community Common Areas & Lake Doctor/Retention Ponds:**

1. All lakes have been inspected by the Lake Doctors, minor treatment required.
2. Finalized work between Clay County and Tree Amigos on Signal Light installation. All repairs are completed.
3. No treatment are necessary for most all bad lakes, will pick up as we head into spring.
4. Continue to look for dead trees throughout the community along back of houses

### **Community Landscaping/Tree Amigos:**

- a. Tree Amigos Landscape - Grounds are being maintained per the contract. Maintenance services provided to Eagle Landing by Tree Amigos February 1 to February 28, 2025.
- b. Ongoing maintenance per schedule for mowing and detail operations.



- c. Fertilization, preventative insecticide, and pre-emergent herbicide is scheduled the week of 2/20/25
- d. Main entrance and roadway island Plant replacement was completed coming in nicely
- e. Damaged turf area at main entrance to Eagle Landing due to construction sodded the week of 2/13/25
- f. Pond island enhancement proposal and Pickel Ball court washout prevention proposal sent and we are making final changes. Island Stage 1 &2 is a go. Working on plant layout on island.
- g. We have completed our Winter cut backs starting our winter in-contract limb ups and leaf cleanup

**Misc:**

1. Answered numerous phone calls, emails and visits from residents, contractors, vendors and other persons with inquiries. The subjects included, golf course maintenance, easement encroachments, lake maintenance, repairs, drainage (both County and CDD owned), dead trees, etc
2. Facilities are inspected on a weekly basis
3. The parks and playgrounds are inspected weekly and required repairs are made.
4. Daily trash pickup along parkway, park sites and common areas.
5. Amenity and common area cameras reviewed;
6. New maintenance person hired doing a great job
7. Surveys sent/reviewed for Rec, Golf, F&B

**Questions/Comments:**

Should you have any questions or comments regarding the above information, please feel free to contact Jim Hahn at [jhahn@troon.com](mailto:jhahn@troon.com) 904-637-0648.

*ELEVENTH ORDER OF BUSINESS*

*A.*

***South Village***  
***Community Development District***

***Unaudited Financial Reporting***  
***January 31, 2025***



# Table of Contents

1	<u>Balance Sheet</u>
2-3	<u>General Fund</u>
4-5	<u>Golf Course Enterprise Fund</u>
6	<u>Debt Service Fund Series 2016A1 &amp; A2</u>
7	<u>Debt Service Fund Series 2016A3</u>
8	<u>Debt Service Fund Series 2019A/B</u>
9	<u>Capital Project Fund Series 2016A1 &amp; A2</u>
10-11	<u>Month to Month</u>
12-13	<u>Long Term Debt Report</u>
14	<u>Assessment Receipt Schedule</u>

**South Village**  
**Community Development District**  
**Combined Balance Sheet**  
**January 31, 2025**

	General Fund	Debt Service Fund	Capital Project Fund	Enterprise Fund	Totals Governmental Funds
<b>Assets:</b>					
<b>Cash:</b>					
Operating Account	\$ 171,817	\$ -	\$ -	\$ 2,131,397	\$ 2,303,214
Accounts Receivable	-	-	-	55,890	55,890
Due from General	-	0	-	0	0
Due from Debt Service	-	-	-	-	-
Due from Rec Fund	-	-	-	-	-
Due from Golf Course	-	-	-	-	-
<b>Investments:</b>					
State Board of Administration (SBA)	1,216,552	-	-	-	1,216,552
<b>Series 2016 A1/A2</b>					
Reserve A1	-	540,686	-	-	540,686
Reserve A2	-	192,934	-	-	192,934
Interest A1	-	-	-	-	-
Interest A2	-	-	-	-	-
Revenue A1/A2	-	1,589,574	-	-	1,589,574
Prepayment A1	-	-	-	-	-
Prepayment A2	-	-	-	-	-
Sinking A1	-	-	-	-	-
Sinking A2	-	-	-	-	-
Construction	-	-	1,527	-	1,527
<b>Series 2016 A3</b>					
Reserve A3	-	137,002	-	-	137,002
Revenue A3	-	339,921	-	-	339,921
Prepayment A3	-	-	-	-	-
Interest A3	-	-	-	-	-
<b>Series 2019A/B</b>					
Reserve A	-	62,953	-	-	62,953
Revenue A	-	239,981	-	-	239,981
Interest B	-	1,312	-	-	1,312
Prepayment B	-	1,975	-	-	1,975
Prepaid Expenses	-	-	-	137,164	137,164
Inventory	-	-	-	155,360	155,360
Deposits	-	-	-	15,753	15,753
<b>Non-Current Assets:</b>					
Property & Equipment (Net)	-	-	-	2,367,849	2,367,849
<b>Total Assets</b>	<b>\$ 1,388,369</b>	<b>\$ 3,106,338</b>	<b>\$ 1,527</b>	<b>\$ 4,863,413</b>	<b>\$ 9,359,646</b>
<b>Liabilities:</b>					
Accounts Payable	\$ 58,879	-	\$ -	\$ 50,444	\$ 109,323
Accrued Payroll & PTO	-	-	-	59,011	59,011
Due to Other Funds	0	-	-	-	0
Deferred Revenues	-	-	-	283,472	283,472
<b>Total Liabilities</b>	<b>\$ 58,879</b>	<b>\$ -</b>	<b>\$ -</b>	<b>\$ 392,926</b>	<b>\$ 451,805</b>
<b>Fund Balance:</b>					
<b>Nonspendable:</b>					
Prepaid Items	\$ -	\$ -	\$ -	\$ 137,164	\$ 137,164
Deposits	-	-	-	15,753	15,753
<b>Restricted for:</b>					
Debt Service	-	3,106,338	-	-	3,106,338
Capital Projects	66,000	-	1,527	-	67,527
<b>Assigned for:</b>					
Capital Reserves	-	-	-	-	-
Restricted for Golf Course	-	-	-	4,317,569	4,317,569
Unassigned	1,263,490	-	-	-	1,263,490
<b>Total Fund Balances</b>	<b>\$ 1,329,490</b>	<b>\$ 3,106,338</b>	<b>\$ 1,527</b>	<b>\$ 4,470,486</b>	<b>\$ 8,907,841</b>
<b>Total Liabilities &amp; Fund Balance</b>	<b>\$ 1,388,369</b>	<b>\$ 3,106,338</b>	<b>\$ 1,527</b>	<b>\$ 4,863,413</b>	<b>\$ 9,359,646</b>

**South Village**  
**Community Development District**  
**General Fund**  
**Statement of Revenues, Expenditures, and Changes in Fund Balance**  
**For The Period Ending January 31, 2025**

	Adopted Budget	Prorated Budget Thru 01/31/25	Actual Thru 01/31/25	Variance
<b>Revenues:</b>				
Special Assessments - Tax Roll	\$ 796,099	\$ 768,251	\$ 768,251	\$ -
Interest Income	15,000	5,000	12,252	7,252
<b>Total Revenues</b>	<b>\$ 811,099</b>	<b>\$ 773,251</b>	<b>\$ 780,503</b>	<b>\$ 7,252</b>
<b>Expenditures:</b>				
<b>General &amp; Administrative:</b>				
Supervisor Fees	\$ 13,000	\$ 4,333	\$ 3,800	\$ 533
PR-FICA	995	332	291	41
Engineering	10,000	3,333	9,163	(5,829)
Arbitrage Rebate	1,800	600	-	600
Dissemination Agent	9,551	3,184	3,184	(0)
Assessment Administration	5,955	5,955	5,955	-
Attorney	35,000	11,667	3,555	8,112
Annual Audit	8,500	8,500	-	8,500
Trustee Fees	14,650	4,883	-	4,883
Management Fees	58,427	19,476	19,476	(0)
Information Technology	2,022	674	674	-
Website Admin	1,272	424	424	-
Telephone	1,500	500	383	117
Postage & Delivery	1,000	333	109	224
Insurance General Liability	21,257	21,257	20,676	581
Printing & Binding	2,000	667	381	286
Legal Advertising	4,000	1,333	501	832
Other Current Charges	2,500	833	620	214
Office Supplies	100	33	9	24
Dues, Licenses & Subscriptions	175	175	175	-
Contingency	500	-	-	-
<b>Total General &amp; Administrative</b>	<b>\$ 194,204</b>	<b>\$ 88,493</b>	<b>\$ 69,374</b>	<b>\$ 19,119</b>

**South Village**  
**Community Development District**  
**General Fund**  
**Statement of Revenues, Expenditures, and Changes in Fund Balance**  
**For The Period Ending January 31, 2025**

	Adopted Budget	Prorated Budget Thru 01/31/25	Actual Thru 01/31/25	Variance
<b><i>Operations &amp; Maintenance</i></b>				
<b>Community Appearance</b>				
Security	\$ 52,000	\$ 17,333	\$ 37,188	\$ (19,854)
Utilities	118,233	39,411	14,987	24,424
Interlocal Agreement - MVCDD	36,000	36,000	39,299	(3,299)
Landscape - Contract	295,162	98,387	83,723	14,664
Landscape - Contingency	45,000	15,000	-	15,000
Landscape - Irrigation Repairs	10,500	3,500	-	3,500
Repairs & Maintenance	25,000	8,333	117	8,216
Lake - Contract	35,000	11,667	11,448	219
<b>Subtotal Community Appearance</b>	<b>\$ 616,895</b>	<b>\$ 229,632</b>	<b>\$ 186,761</b>	<b>\$ 42,871</b>
<b>Total Operations &amp; Maintenance</b>	<b>\$ 616,895</b>	<b>\$ 229,632</b>	<b>\$ 186,761</b>	<b>\$ 42,871</b>
<b>Total Expenditures</b>	<b>\$ 811,099</b>	<b>\$ 318,124</b>	<b>\$ 256,135</b>	<b>\$ 61,989</b>
<b>Excess (Deficiency) of Revenues over Expenditures</b>	<b>\$ -</b>	<b>\$ 455,126</b>	<b>\$ 524,368</b>	<b>\$ 69,242</b>
<b>Net Change in Fund Balance</b>	<b>\$ -</b>	<b>\$ 455,126</b>	<b>\$ 524,368</b>	<b>\$ 69,242</b>
<b>Fund Balance - Beginning</b>	<b>\$ -</b>		<b>\$ 805,122</b>	
<b>Fund Balance - Ending</b>	<b>\$ -</b>		<b>\$ 1,329,490</b>	



**South Village**  
**Community Development District**  
**Golf Course Operations**

**Statement of Revenues, Expenditures, and Changes in Net Position**  
**For The Period Ending January 31, 2025**

	Adopted Budget	Prorated Budget Thru 01/31/25	Actual Thru 01/31/25	Variance
<b>Operating Revenues:</b>				
PGA/Cart Fees	\$ -	\$ -	\$ 5,075	\$ 5,075
Raincheck Revenue	-	-	(1,180)	(1,180)
Guest Fees	1,640,200	497,528	388,923	(108,605)
Trail Fees	120,000	40,000	42,852	2,852
Tournament Rounds	-	-	53,231	53,231
Other Golf Revenues	79,800	26,500	14,776	(11,724)
Merchandise	234,270	78,400	69,107	(9,293)
Food & Beverage	2,006,039	601,417	526,097	(75,320)
Swim & Tennis	217,998	45,418	18,235	(27,183)
Room Rental	1,000	200	-	(200)
Member Dues	529,500	173,500	189,002	15,502
Fitness	-	-	4,906	4,906
Misc Revenues	-	-	325	325
<b>Total Operating Revenues</b>	<b>\$ 4,828,807</b>	<b>\$ 1,462,963</b>	<b>\$ 1,311,351</b>	<b>\$ (151,612)</b>
<b>Cost of Goods Sold:</b>				
Cost of Goods Sold	\$ 910,231	274,020	265,187	8,833
<b>Total Gross Margin</b>	<b>\$ 3,918,576</b>	<b>\$ 1,188,943</b>	<b>\$ 1,046,164</b>	<b>\$ (142,779)</b>
<b>Operating Expenses:</b>				
<b>Payroll</b>				
Payroll	\$ 2,590,900	799,840	\$ 741,265	\$ 58,575
Employee Benefits	575,162	177,799	187,187	(9,388)
Employee Expenses	43,037	12,846	14,127	(1,281)
<b>Professional Fees</b>				
Legal Fees	3,000	1,000	-	1,000
Other Professional Fees	-	-	1,200	(1,200)
<b>Marketing</b>				
Marketing	133,700	50,772	54,708	(3,936)
<b>Repairs &amp; Maintenance</b>				
Equipment	82,800	35,500	17,098	18,402
Irrigation	10,850	4,950	8,488	(3,538)
Pool	12,000	4,000	382	3,618
Building	7,000	2,340	4,166	(1,826)
Electrical & Mechanical	-	-	-	-
Tennis Courts	13,500	2,400	3,139	(739)
Carts	3,000	1,000	7,483	(6,483)
Sod	3,500	1,000	14,392	(13,392)
Seed & Mulch	4,000	2,000	1,445	555
Sand & Gravel	8,000	2,500	3,115	(615)
Landscaping	-	-	-	-
Gas, Diesel, Oil & Lube	72,000	24,000	20,851	3,149
Small Tools	1,500	500	123	377
Fertilizers	59,500	19,500	23,653	(4,153)
Chemicals - Herbicides	75,000	16,000	40,259	(24,259)
Chemicals - Other	45,000	15,000	18,032	(3,032)
<b>Utilities</b>				
Electric	148,500	42,900	49,080	(6,180)
Natural Gas	9,832	3,932	765	3,167
Cable TV/Music	31,000	10,344	7,546	2,798
Water	34,250	8,450	-	8,450
Waste Removal	48,840	16,280	2,040	14,240
Telephone	23,000	7,672	7,359	313
Pest Control	6,900	2,300	1,226	1,074

**South Village**  
**Community Development District**  
**Golf Course Operations**

**Statement of Revenues, Expenditures, and Changes in Net Position**  
**For The Period Ending January 31, 2025**

	Adopted Budget	Prorated Budget Thru 01/31/25	Actual Thru 01/31/25	Variance
<b>Operating Expenses</b>				
Cart Leases - Operating	138,000	46,000	-	46,000
EZLinks	10,500	3,500	2,950	550
Employee Uniforms	10,500	2,500	1,239	1,261
Handicap Fees	4,500	-	409	(409)
Equipment Rental	2,700	1,200	2,991	(1,791)
Equipment Leases	79,100	-	47,888	(47,888)
Golf Operating Supplies	19,300	9,200	510	8,690
Course Supplies	2,700	900	-	900
Paper Products	82,200	23,500	16,390	7,110
Office Supplies	24,059	79,999	649	79,350
Flowers & Decorations	6,250	2,650	691	1,959
Operating Supplies - M	34,502	9,100	15,331	(6,231)
Operating Supplies - G	15,600	5,200	3,665	1,535
Linens	18,000	6,000	5,439	561
China, Glass & Utensils	8,800	2,600	1,221	1,379
Tournament Expense	4,600	-	7,074	(7,074)
Postage	3,600	1,200	130	1,070
Computers Related	25,800	8,600	10,004	(1,404)
Printing	5,000	1,740	213	1,527
Credit Card Fees	106,604	32,959	35,637	(2,678)
Cash Over/Short	-	-	45	(45)
Bank Fees	3,027	590	5,431	(4,841)
Dues & Subscriptions	2,850	700	815	(115)
Independent Contractor	33,700	11,100	29,272	(18,172)
Insurance	144,000	48,000	54,971	(6,971)
Property Taxes	42,100	41,300	17,280	24,020
Other Taxes	3,801	-	-	-
Fees, Permits & Licenses	5,358	2,853	(227)	3,080
Base Management Fees	182,000	60,672	65,253	(4,581)
Capital Expenditures	-	-	102,561	(102,561)
<b>Total Operating Expenses:</b>	<b>\$ 5,064,922</b>	<b>\$ 1,666,888</b>	<b>\$ 1,656,961</b>	<b>\$ 9,927</b>
<b>Net Income before Non-Operating Income (Expenses)</b>	<b>\$ (1,146,346)</b>	<b>\$ (477,945)</b>	<b>\$ (610,797)</b>	<b>\$ (132,852)</b>
<b>Non-Operating Income/(Expenses):</b>				
Mandatory Initiation Fees	\$ 12,000	\$ 4,000	\$ 12,500	\$ 8,500
Rec Fund Assessments	1,143,399	1,104,859	1,104,859	-
Cap Reserve Assessments	679,710	657,233	657,233	-
Interest Income	-	-	7,277	7,277
<b>Total Non-Operating Income/(Expenses):</b>	<b>\$ 1,835,109</b>	<b>\$ 1,766,092</b>	<b>\$ 1,781,869</b>	<b>\$ 15,777</b>
<b>Change in Net Position</b>	<b>\$ 688,763</b>	<b>\$ 1,288,147</b>	<b>\$ 1,171,072</b>	<b>\$ (117,075)</b>
<b>Total Net Position - Beginning</b>	<b>\$ -</b>		<b>\$ 3,299,414</b>	
<b>Total Net Position - Ending</b>	<b>\$ 688,763</b>		<b>\$ 4,470,486</b>	

**South Village**  
**Community Development District**  
**Debt Service Fund Series 2016A1/A2**  
**Statement of Revenues, Expenditures, and Changes in Fund Balance**  
**For The Period Ending January 31, 2025**

	Adopted Budget	Prorated Budget Thru 01/31/25	Actual Thru 01/31/25	Variance
<b>Revenues:</b>				
Special Assessments - Tax Roll	\$ 1,477,362	\$ 1,419,554	\$ 1,419,554	-
Prepayments	-	-	-	-
Interest Income	-	-	18,963	18,963
<b>Total Revenues</b>	<b>\$ 1,477,362</b>	<b>\$ 1,419,554</b>	<b>\$ 1,438,517</b>	<b>\$ 18,963</b>
<b>Expenditures:</b>				
<b>Series 2016 A-1 Refunding Bonds</b>				
Interest Expense - 11/1	\$ 148,094	\$ 148,094	\$ 148,094	-
Special Call - 11/1	-	-	35,000	(35,000)
Interest Expense - 5/1	148,094	-	-	-
Principal Expense - 5/1	660,000	-	-	-
<b>Series 2016 A-1 Revenue Bonds</b>				
Interest Expense - 11/1	56,625	56,625	56,625	-
Interest Expense - 5/1	56,625	-	-	-
<b>Series 2016 A-2 Refunding Bonds</b>				
Interest Expense - 11/1	69,951	69,951	69,951	-
Special Call - 11/1	-	-	15,000	(15,000)
Principal Expense - 5/1	205,000	-	-	-
Interest Expense - 5/1	69,951	-	-	-
<b>Series 2016 A-2 Revenue Bonds</b>				
Interest Expense - 11/1	20,750	20,750	20,750	-
Interest Expense - 5/1	20,750	-	-	-
<b>Total Expenditures</b>	<b>\$ 1,455,839</b>	<b>\$ 295,419</b>	<b>\$ 345,419</b>	<b>\$ (50,000)</b>
<b>Excess (Deficiency) of Revenues over Expenditures</b>	<b>\$ 21,523</b>	<b>\$ 1,124,134</b>	<b>\$ 1,093,097</b>	<b>\$ (31,037)</b>
<b>Net Change in Fund Balance</b>	<b>\$ 21,523</b>	<b>\$ 1,124,134</b>	<b>\$ 1,093,097</b>	<b>\$ (31,037)</b>
<b>Fund Balance - Beginning</b>	<b>\$ 369,283</b>		<b>\$ 1,230,097</b>	
<b>Fund Balance - Ending</b>	<b>\$ 390,806</b>		<b>\$ 2,323,194</b>	

# South Village

## Community Development District

### Debt Service Fund Series 2016A3

#### Statement of Revenues, Expenditures, and Changes in Fund Balance

For The Period Ending January 31, 2025

	Adopted	Prorated Budget	Actual	
	Budget	Thru 01/31/25	Thru 01/31/25	Variance
<b>Revenues:</b>				
Special Assessments - Tax Roll	\$ 274,807	\$ 266,141	\$ 266,141	-
Interest Income	-	-	4,405	4,405
<b>Total Revenues</b>	<b>\$ 274,807</b>	<b>\$ 266,141</b>	<b>\$ 270,546</b>	<b>\$ 4,405</b>
<b>Expenditures:</b>				
<b>Series 2016 A-3 Refunding Bonds</b>				
Interest Expense - 11/1	\$ 38,025	\$ 38,025	\$ 38,025	-
Interest Expense - 5/1	38,025	-	-	-
Principal Expense - 5/1	85,000	-	-	-
<b>Series 2016 A-3 Revenue Bonds</b>				
Interest Expense - 11/1	53,500	53,500	53,500	-
Interest Expense - 5/1	53,500	-	-	-
<b>Total Expenditures</b>	<b>\$ 268,050</b>	<b>\$ 91,525</b>	<b>\$ 96,525</b>	<b>\$ (5,000)</b>
<b>Excess (Deficiency) of Revenues over Expenditures</b>	<b>\$ 6,757</b>	<b>\$ 174,616</b>	<b>\$ 174,021</b>	<b>\$ (595)</b>
<b>Total Other Financing Sources/(Uses)</b>	<b>\$ -</b>	<b>\$ -</b>	<b>\$ -</b>	<b>\$ -</b>
<b>Net Change in Fund Balance</b>	<b>\$ 6,757</b>	<b>\$ 174,616</b>	<b>\$ 174,021</b>	<b>\$ (595)</b>
<b>Fund Balance - Beginning</b>	<b>\$ 138,689</b>		<b>\$ 302,901</b>	
<b>Fund Balance - Ending</b>	<b>\$ 145,446</b>		<b>\$ 476,922</b>	

**South Village**  
**Community Development District**  
**Debt Service Fund Series 2019A/B**  
**Statement of Revenues, Expenditures, and Changes in Fund Balance**  
**For The Period Ending January 31, 2025**

	Adopted Budget	Prorated Budget Thru 01/31/25	Actual Thru 01/31/25	Variance
<b>Revenues:</b>				
Special Assessments - Tax Roll	\$ 223,713	\$ 213,504	\$ 213,504	\$ -
Interest Income	-	-	2,436	2,436
<b>Total Revenues</b>	<b>\$ 223,713</b>	<b>\$ 213,504</b>	<b>\$ 215,940</b>	<b>\$ 2,436</b>
<b>Expenditures:</b>				
<b>Series 2019A</b>				
Interest Expense - 11/1	\$ 80,793	\$ 80,793	\$ 80,793	\$ -
Interest Expense - 5/1	80,793	-	-	-
Principal Expense - 5/1	60,000	-	-	-
<b>Total Expenditures</b>	<b>\$ 221,585</b>	<b>\$ 80,793</b>	<b>\$ 80,793</b>	<b>\$ -</b>
<b>Excess (Deficiency) of Revenues over Expenditures</b>	<b>\$ 2,128</b>	<b>\$ 132,711</b>	<b>\$ 135,147</b>	<b>\$ 2,436</b>
<b>Total Other Financing Sources/(Uses)</b>	<b>\$ -</b>	<b>\$ -</b>	<b>\$ -</b>	<b>\$ -</b>
<b>Net Change in Fund Balance</b>	<b>\$ 2,128</b>	<b>\$ 132,711</b>	<b>\$ 135,147</b>	<b>\$ 2,436</b>
<b>Fund Balance - Beginning</b>	<b>\$ 100,032</b>		<b>\$ 171,073</b>	
<b>Fund Balance - Ending</b>	<b>\$ 102,160</b>		<b>\$ 306,221</b>	

**South Village**  
**Community Development District**  
**Capital Projects Fund Series 2016A1/A2**  
**Statement of Revenues, Expenditures, and Changes in Fund Balance**  
**For The Period Ending January 31, 2025**

	Adopted Budget	Prorated Budget Thru 01/31/25	Actual Thru 01/31/25	Variance
<b>Revenues</b>				
Developer Contributions	\$ -	\$ -	\$ 160	\$ 160
Interest Income	-	-	-	-
<b>Total Revenues</b>	<b>\$ -</b>	<b>\$ -</b>	<b>\$ 160</b>	<b>\$ 160</b>
<b>Expenditures:</b>				
Improvements	\$ -	\$ -	\$ 9,410	\$ (9,410)
<b>Total Expenditures</b>	<b>\$ -</b>	<b>\$ -</b>	<b>\$ 9,410</b>	<b>\$ (9,410)</b>
<b>Excess (Deficiency) of Revenues over Expenditures</b>	<b>\$ -</b>	<b>\$ -</b>	<b>\$ (9,250)</b>	<b>\$ (9,250)</b>
<b>Net Change in Fund Balance</b>	<b>\$ -</b>	<b>\$ -</b>	<b>\$ (9,250)</b>	
<b>Fund Balance - Beginning</b>	<b>\$ -</b>		<b>\$ 10,776</b>	
<b>Fund Balance - Ending</b>	<b>\$ -</b>		<b>\$ 1,527</b>	

**South Village**  
**Community Development District**  
**Month to Month**

	Adopted Budget	Oct	Nov	Dec	Jan	Feb	March	April	May	June	July	Aug	Sept	Total
<b>Revenues:</b>														
Special Assessments - Tax Roll	\$ 796,099	\$ -	\$ 63,485	\$ 693,524	\$ 11,242	\$ -	\$ -	\$ -	\$ -	\$ -	\$ -	\$ -	\$ -	\$ 768,251
Special Assessments - Direct	-	-	-	-	-	-	-	-	-	-	-	-	-	-
Interest Income	15,000	3,195	2,518	2,436	4,104	-	-	-	-	-	-	-	-	12,252
<b>Total Revenues</b>	<b>\$ 811,099</b>	<b>\$ 3,195</b>	<b>\$ 66,003</b>	<b>\$ 695,959</b>	<b>\$ 15,346</b>	<b>\$ -</b>	<b>\$ -</b>	<b>\$ -</b>	<b>\$ -</b>	<b>\$ -</b>	<b>\$ -</b>	<b>\$ -</b>	<b>\$ -</b>	<b>\$ 780,503</b>
<b>Expenditures:</b>														
<b>General &amp; Administrative:</b>														
Supervisor Fees	\$ 13,000	\$ 800	\$ 1,600	\$ 600	\$ 800	\$ -	\$ -	\$ -	\$ -	\$ -	\$ -	\$ -	\$ -	\$ 3,800
PR-FICA	995	61	122	46	61	-	-	-	-	-	-	-	-	291
Engineering	10,000	5,020	4,143	-	-	-	-	-	-	-	-	-	-	9,163
Attorney	35,000	-	3,555	-	-	-	-	-	-	-	-	-	-	3,555
Annual Audit	8,500	-	-	-	-	-	-	-	-	-	-	-	-	-
Assessment Administration	5,955	5,955	-	-	-	-	-	-	-	-	-	-	-	5,955
Arbitrage Rebate	1,800	-	-	-	-	-	-	-	-	-	-	-	-	-
Dissemination Agent	9,551	796	796	796	796	-	-	-	-	-	-	-	-	3,184
Trustee Fees	14,650	-	-	-	-	-	-	-	-	-	-	-	-	-
Management Fees	58,427	4,869	4,869	4,869	4,869	-	-	-	-	-	-	-	-	19,476
Information Technology	2,022	169	169	169	169	-	-	-	-	-	-	-	-	674
Website Admin	1,272	106	106	106	106	-	-	-	-	-	-	-	-	424
Telephone	1,500	50	60	90	183	-	-	-	-	-	-	-	-	383
Postage & Delivery	1,000	67	40	1	1	-	-	-	-	-	-	-	-	109
Insurance General Liability	21,257	20,676	-	-	-	-	-	-	-	-	-	-	-	20,676
Printing & Binding	2,000	147	131	80	23	-	-	-	-	-	-	-	-	381
Legal Advertising	4,000	-	457	44	-	-	-	-	-	-	-	-	-	501
Other Current Charges	2,500	110	50	460	-	-	-	-	-	-	-	-	-	620
Office Supplies	100	0	0	0	9	-	-	-	-	-	-	-	-	9
Dues, Licenses & Subscriptions	175	175	-	-	-	-	-	-	-	-	-	-	-	175
Contingency	500	-	-	-	-	-	-	-	-	-	-	-	-	-
<b>Total General &amp; Administrative</b>	<b>\$ 194,204</b>	<b>\$ 39,000</b>	<b>\$ 16,097</b>	<b>\$ 7,260</b>	<b>\$ 7,016</b>	<b>\$ -</b>	<b>\$ -</b>	<b>\$ -</b>	<b>\$ -</b>	<b>\$ -</b>	<b>\$ -</b>	<b>\$ -</b>	<b>\$ -</b>	<b>\$ 69,374</b>

**South Village**  
**Community Development District**  
**Month to Month**

	Adopted Budget	Oct	Nov	Dec	Jan	Feb	March	April	May	June	July	Aug	Sept	Total
<b>Operations &amp; Maintenance</b>														
<b>Community Appearance</b>														
Security	\$ 52,000	\$ 10,625	\$ 10,625	\$ 7,969	\$ 7,969	\$ -	\$ -	\$ -	\$ -	\$ -	\$ -	\$ -	\$ -	\$ 37,188
Utilities	118,233	7,466	5,042	2,479	-	-	-	-	-	-	-	-	-	14,987
Interlocal Agreement - MVCDD	36,000	-	-	-	39,299	-	-	-	-	-	-	-	-	39,299
Landscape - Contract	295,162	19,580	19,580	19,580	19,580	-	-	-	-	-	-	-	-	78,321
Landscape - Contingency	45,000	-	-	5,402	-	-	-	-	-	-	-	-	-	5,402
Landscape - Irrigation Repairs	10,500	-	-	-	-	-	-	-	-	-	-	-	-	-
Phase 5&6 Maintenance	-	-	-	-	-	-	-	-	-	-	-	-	-	-
Repairs & Maintenance	25,000	-	117	-	-	-	-	-	-	-	-	-	-	117
Lake - Contract	35,000	2,862	2,862	2,862	2,862	-	-	-	-	-	-	-	-	11,448
<b>Subtotal Community Appearance</b>	<b>\$ 616,895</b>	<b>\$ 40,533</b>	<b>\$ 38,227</b>	<b>\$ 38,292</b>	<b>\$ 69,710</b>	<b>\$ -</b>	<b>\$ -</b>	<b>\$ -</b>	<b>\$ -</b>	<b>\$ -</b>	<b>\$ -</b>	<b>\$ -</b>	<b>\$ -</b>	<b>\$ 186,761</b>
<b>Total Operations &amp; Maintenance</b>	<b>\$ 616,895</b>	<b>\$ 40,533</b>	<b>\$ 38,227</b>	<b>\$ 38,292</b>	<b>\$ 69,710</b>	<b>\$ -</b>	<b>\$ -</b>	<b>\$ -</b>	<b>\$ -</b>	<b>\$ -</b>	<b>\$ -</b>	<b>\$ -</b>	<b>\$ -</b>	<b>\$ 186,761</b>
<b>Total Expenditures</b>	<b>\$ 79,533</b>	<b>\$ 54,324</b>	<b>\$ 45,552</b>	<b>\$ 76,726</b>	<b>\$ -</b>	<b>\$ -</b>	<b>\$ -</b>	<b>\$ -</b>	<b>\$ -</b>	<b>\$ -</b>	<b>\$ -</b>	<b>\$ -</b>	<b>\$ -</b>	<b>\$ 256,135</b>
<b>Excess (Deficiency) of Revenues over Expenditures</b>	<b>\$ (76,338)</b>	<b>\$ 11,679</b>	<b>\$ 650,407</b>	<b>\$ (61,379)</b>	<b>\$ -</b>	<b>\$ -</b>	<b>\$ -</b>	<b>\$ -</b>	<b>\$ -</b>	<b>\$ -</b>	<b>\$ -</b>	<b>\$ -</b>	<b>\$ -</b>	<b>\$ 524,368</b>
<b>Net Change in Fund Balance</b>	<b>\$ (76,338)</b>	<b>\$ 11,679</b>	<b>\$ 650,407</b>	<b>\$ (61,379)</b>	<b>\$ -</b>	<b>\$ -</b>	<b>\$ -</b>	<b>\$ -</b>	<b>\$ -</b>	<b>\$ -</b>	<b>\$ -</b>	<b>\$ -</b>	<b>\$ -</b>	<b>\$ 524,368</b>



**South Village**  
**Community Development District**  
**Long Term Debt Report**

**Series 2016A1/A2/A3 Capital Improvement Revenue and Refunding Bonds**

Original Issue Amount: \$28,085,000  
Interest Rate: 2.0% - 5.0%  
Maturity Date: 05/01/46

Bonds outstanding	06/23/16	\$28,085,000	\$17,075,000	\$5,480,000	\$5,530,000
Less:	11/01/16 A1	(\$30,000)	(\$30,000)		
	11/01/16 A2	(\$10,000)		(\$10,000)	
	05/01/17 A1	(\$595,000)	(\$595,000)		
	05/01/17 A2	(\$165,000)		(\$165,000)	
	05/01/17 A3	(\$100,000)			(\$100,000)
	11/01/17 A1	(\$10,000)	(\$10,000)		
	11/01/17 A2	(\$5,000)		(\$5,000)	
	11/01/17 A3	(\$55,000)			(\$55,000)
	05/01/18 A1	(\$600,000)	(\$600,000)		
	05/01/18 A2	(\$205,000)		(\$205,000)	
	05/01/18 A3	(\$190,000)			(\$190,000)
	08/01/18 A3	(\$35,000)			(\$35,000)
	11/01/18 A1	(\$25,000)	(\$25,000)		
	11/01/18 A2	(\$10,000)		(\$10,000)	
	11/01/18 A3	(\$155,000)			(\$155,000)
	02/01/19 A3	(\$40,000)			(\$40,000)
	05/01/19 A1	(\$655,000)	(\$655,000)		
	05/01/19 A2	(\$190,000)		(\$190,000)	
	05/01/19 A3	(\$175,000)			(\$175,000)
	08/01/19 A3	(\$65,000)			(\$65,000)
	11/01/19 A1	(\$10,000)	(\$10,000)		
	11/01/19 A2	(\$5,000)		(\$5,000)	
	11/01/19 A3	(\$100,000)			(\$100,000)
	02/01/20 A3	(\$45,000)			(\$45,000)
	05/01/20 A1	(\$630,000)	(\$630,000)		
	05/01/20 A2	(\$180,000)		(\$180,000)	
	05/01/20 A3	(\$130,000)			(\$130,000)
	08/01/20 A3	(\$30,000)			(\$30,000)
	11/01/20 A1	(\$15,000)	(\$15,000)		
	11/01/20 A2	(\$5,000)		(\$5,000)	
	11/01/20 A3	(\$130,000)			(\$130,000)
	02/01/21 A3	(\$110,000)			(\$110,000)
	05/01/21 A1	(\$865,000)	(\$865,000)		
	05/01/21 A2	(\$265,000)		(\$265,000)	
	05/01/21 A3	(\$180,000)			(\$180,000)
	08/01/21 A3	(\$95,000)			(\$95,000)
	11/01/21 A1	(\$25,000)	(\$25,000)		
	11/01/21 A2	(\$10,000)		(\$10,000)	
	11/01/21 A3	(\$40,000)			(\$40,000)
	02/01/22 A3	(\$45,000)			(\$45,000)
	05/01/22 A1	(\$620,000)	(\$620,000)		
	05/01/22 A2	(\$255,000)		(\$255,000)	
	05/01/22 A3	(\$180,000)			(\$180,000)
	08/01/22 A2	(\$35,000)		(\$35,000)	
	08/01/22 A3	(\$35,000)			(\$35,000)
	11/01/22 A1	(\$5,000)	(\$5,000)		
	11/01/22 A2	(\$5,000)		(\$5,000)	
	05/01/23 A1	(\$635,000)	(\$635,000)		
	05/01/23 A2	(\$210,000)		(\$210,000)	
	05/01/23 A3	(\$85,000)			(\$85,000)
	11/01/23 A1	(\$25,000)	(\$25,000)		
	11/01/23 A2	(\$10,000)		(\$10,000)	
	05/01/24 A1	(\$655,000)	(\$655,000)		
	05/01/24 A2	(\$205,000)		(\$205,000)	
	05/01/24 A3	(\$80,000)			(\$80,000)
	11/01/24 A1	(\$35,000)	(\$35,000)		
	11/01/24 A2	(\$15,000)		(\$15,000)	
	11/01/24 A3	(\$5,000)			(\$5,000)
<b>Current Bonds Outstanding:</b>		<b>\$18,760,000</b>	<b>\$11,640,000</b>	<b>\$3,695,000</b>	<b>\$3,425,000</b>

**South Village**  
**Community Development District**  
**Long Term Debt Report**

**Series 2019A/B Capital Improvement Revenue Bonds**

Original Issue Amount: \$4,955,000  
Interest Rate: 4.75% - 5.6%  
Maturity Date: 05/01/49

Reserve Fund Requirement: 25% of MADS

		Total	A	B
Bonds outstanding	02/28/19	\$4,955,000	\$3,255,000	\$1,700,000
Less:	11/01/19	B (\$60,000)		(\$60,000)
	02/01/20	B (\$190,000)		(\$190,000)
	05/01/20	A (\$45,000)	(\$45,000)	
	08/01/20	B (\$190,000)		(\$190,000)
	11/01/20	B (\$125,000)		(\$125,000)
	02/01/21	B (\$145,000)		(\$145,000)
	05/01/21	A (\$45,000)	(\$45,000)	
	05/01/21	B (\$150,000)		(\$150,000)
	08/01/21	B (\$170,000)		(\$170,000)
	11/01/21	B (\$165,000)		(\$165,000)
	02/01/22	B (\$190,000)		(\$190,000)
	05/01/22	B (\$210,000)		(\$210,000)
	08/01/22	B (\$65,000)		(\$65,000)
	11/01/22	B (\$40,000)		(\$40,000)
	05/01/23	A (\$95,000)	(\$95,000)	
	05/01/24	A (\$55,000)	(\$55,000)	
<b>Current Bonds Outstanding:</b>		<b>\$3,015,000</b>	<b>\$3,015,000</b>	<b>\$0</b>

*B.*

**SOUTH VILLAGE COMMUNITY DEVELOPMENT DISTRICT**

**Fiscal Year 2025 Assessment Receipt Summary**

ASSESSED	# UNITS ASSESSED	SERIES 2016A1-2 DEBT SERVICE ASSESSED	SERIES 2016A-3 DEBT SERVICE ASSESSED	SERIES 2019A DEBT SERVICE ASSESSED	FY25 O&M ASSESSED	TOTAL ASSESSED
NET TAX ROLL ASSESSED	1,495	1,469,070.62	275,424.61	220,951.14	2,618,606.37	4,584,052.74
<b>TOTAL ASSESSED</b>	<b>1,495</b>	<b>1,469,070.62</b>	<b>275,424.61</b>	<b>220,951.14</b>	<b>2,618,606.37</b>	<b>4,584,052.74</b>

DUE / RECEIVED		SERIES 2016A1-2 DEBT SERVICE PAID	SERIES 2016A-3 DEBT SERVICE PAID	SERIES 2019A DEBT SERVICE PAID	O&M PAID	TOTAL PAID
TAX ROLL RECEIVED		1,432,105.15	268,494.24	215,391.46	2,552,715.72	4,468,706.57
<b>BALANCE DUE</b>		<b>36,965.47</b>	<b>6,930.37</b>	<b>5,559.68</b>	<b>65,890.65</b>	<b>115,346.17</b>

SUMMARY OF TAX ROLL RECEIPTS						
CLAY COUNTY DISTRIBUTION	DATE RECEIVED	SERIES 2016A1-2 DEBT RECEIPTS	SERIES 2016A-3 DEBT RECEIPTS	SERIES 2019A DEBT RECEIPTS	O&M RECEIPTS	TOTAL RECEIVED
1	11/7/2024	7,280.88	1,365.04	1,095.06	12,978.10	22,719.08
2	11/13/2024	45,772.95	8,581.61	6,884.34	81,589.93	142,828.83
3	11/26/2024	64,251.89	12,046.09	9,663.61	114,528.48	200,490.07
4	12/6/2024	1,231,998.10	230,977.73	185,294.96	2,196,026.53	3,844,297.32
5	12/19/2024	49,476.58	9,275.98	7,441.38	88,191.60	154,385.54
6	1/27/2025	20,773.35	3,894.63	3,124.35	37,028.32	64,820.65
7	2/6/2025	12,551.40	2,353.16	1,887.76	22,372.76	39,165.08
		-	-	-	-	
		-	-	-	-	
		-	-	-	-	
		-	-	-	-	
		-	-	-	-	
		-	-	-	-	
		-	-	-	-	
		-	-	-	-	
		-	-	-	-	
<b>TOTAL RECEIVED TAX ROLL</b>		<b>1,432,105.15</b>	<b>268,494.24</b>	<b>215,391.46</b>	<b>2,552,715.72</b>	<b>4,468,706.57</b>

PERCENT COLLECTED	SERIES 2016A1-2	SERIES 2016A-3	SERIES 2019A	O&M	TOTAL
<b>% COLLECTED TAX ROLL</b>	<b>97.48%</b>	<b>97.48%</b>	<b>97.48%</b>	<b>97.48%</b>	<b>97.48%</b>

*C.*

**South Village**  
**COMMUNITY DEVELOPMENT DISTRICT**

**Fiscal Year 2025**  
**Check Register**

<i>Fund</i>	<i>Date</i>	<i>check #'s</i>	<i>Amount</i>
<i>General Fund</i>	1/1-1/31	3592-3596	\$36,755.00
	<i>ACH</i>	<i>80020-80021</i>	\$2,478.59
<i>Rec Fund</i>	1/1-1/31	21594-21604	\$18,656.52
	<i>ACH</i>		\$2,805.14
<i>Golf Fund</i>	1/1-1/31	15661-15732	\$82,356.32
	<i>ACH</i>		\$68,238.49
<i>Cap Reserve</i>	1/1-1/31	1266-1271	\$27,043.58
<b>TOTAL</b>			<b>\$238,333.64</b>

CHECK DATE	VEND#	.....INVOICE..... DATE INVOICE	...EXPENSED TO... YRMO DPT ACCT# SUB SUBCLASS	VENDOR NAME	STATUS	AMOUNT	....CHECK..... AMOUNT #
1/24/25	00060	12/26/24	2024-290 202412 310-51300-48000	NOTICE OF MEETING CLAY TODAY NEWSPAPER	*	44.10	44.10 003592
1/24/25	00127	10/16/24	28 202410 310-51300-49000	AMORT SCHED SR16A-2 40K	*	250.00	
		10/16/24	28 202410 310-51300-49000	AMORT SCHED SR16A-1 15K	*	100.00	
		10/16/24	28 202410 310-51300-49000	AMORT SCHED SR16A-2 5K	*	100.00	
				DISCLOSURE SERVICES, LLC			450.00 003593
1/24/25	00018	1/01/25	318 202501 310-51300-34000	JAN 25 - MGMT FEES	*	4,868.92	
		1/01/25	318 202501 310-51300-35100	JAN 25 - IT	*	168.50	
		1/01/25	318 202501 310-51300-31300	JAN 25 - DISSEMINATION	*	795.92	
		1/01/25	318 202501 310-51300-49500	JAN 25 - WEBSITE ADMIN	*	106.00	
		1/01/25	318 202501 310-51300-51000	JAN 25 - OFFICE SUPPLIES	*	8.72	
		1/01/25	318 202501 310-51300-42000	JAN 25 - POSTAGE	*	.69	
		1/01/25	318 202501 310-51300-42500	JAN 25 - COPIES	*	22.80	
		1/01/25	318 202501 310-51300-41000	JAN 25 - TELEPHONE	*	183.10	
				GOVERNMENTAL MANAGEMENT SERVICES			6,154.65 003594
1/24/25	00063	12/16/24	232798B 202412 320-57200-46800	DEC 24 - LAKE CONTRACT	*	2,862.00	
		1/02/25	240044B 202501 320-57200-46800	JAN 25 - LAKE CONTRACT	*	2,862.00	
				THE LAKE DOCTORS, INC.			5,724.00 003595
1/24/25	00182	12/13/24	688968 202412 320-57200-46200	INST FLOWER BED SOIL	*	1,025.00	
		12/13/24	688969 202412 320-57200-46200	INST WINTER FLOWERS	*	1,550.00	
		12/23/24	689551 202412 320-57200-46200	INST ST. AUGUSTINE SOD	*	1,922.00	
		12/31/24	690512 202412 320-57200-46200	DEC 24 LANDSCAPE CONTRACT	*	19,580.25	
		12/31/24	691617 202412 320-57200-46200	REPAIRD MAINLINE	*	305.00	
				RUPPERT COMPANIES, LLC			24,382.25 003596
				TOTAL FOR BANK A		36,755.00	
				SVIL SOUTH VILLAGE PPOWERS			

# CLAY TODAY

A Division of Osteen Media Group

Clay Today  
3513 US Hwy 17  
Fleming Island, FL 32003  
904-264-3200

**BILL TO**  
Sarah Sweeting  
South Village CDD c/o GMS LLC  
475 W TOWN PL  
#114  
ST AUGUSTINE, FL 32092

## INVOICE

Invoice Number: 2024-290951  
Invoice Date: 12/26/2024  
Due Date: 1/23/2025

Advertiser  
South Village CDD c/o GMS LLC

Customer ID  
20081

Invoice Notes	PO #	Pub.	Issue	Year	Ad Title	Ad Size	Color	Ad Inch	Net
Legal # 132791	Notice of Meeting January 7, 2025	CT - Clay Today	Dec 26	2024		Column Inch	Black & White	4.2000	\$44.10
<b>Total:</b>									<b>\$44.10</b>

**Please mail payments to:**  
**Osteen Media Group**  
**3513 US Hwy 17**  
**Fleming Island Florida 32003**

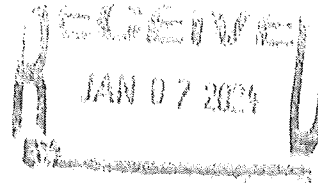

Affidavit attached to this invoice.

Please call the office at 904-264-3200 if you would like to pay by credit card.

Please pay from this invoice. Email for inquiries or questions - [legal@claytodayonline.com](mailto:legal@claytodayonline.com). Thank you for your business.



# CLAY TODAY

## PUBLISHER AFFIDAVIT

PUBLISHER AFFIDAVIT  
CLAY TODAY  
Published Weekly  
Fleming Island, Florida

STATE OF FLORIDA  
COUNTY OF CLAY:

Before the undersigned authority personally appeared Hugh Osteen, who on oath says that he is the publisher of the "Clay Today" a newspaper published weekly at Fleming Island in Clay County, Florida; that the attached copy of advertisement  
Being a Notice of Meeting

In the matter of January 7, 2025

LEGAL: 132791

Was published in said newspaper in the issues:

12/26/2024

Affiant further says that said "Clay Today" is a newspaper published at Fleming Island, in said Clay County, Florida, and that the said newspaper has heretofore been continuously published in said Clay County, Florida, Weekly, and has been entered as Periodical material matter at the post Office in Orange Park, in said Clay County, Florida, for period of one year next proceeding the first publication of the attached copy of advertisement; and affiant further says that he has neither paid nor promised any person, firm or corporation any discount, rebate, commission or refund for the purpose of securing this advertisement for publication in the said newspaper.



Sworn to me and subscribed before me 12/26/2024

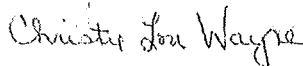

NOTARY PUBLIC, STATE OF FLORIDA

3513 US HWY 17 Fleming Island FL 32003  
Telephone (904) 264-3200  
FAX (904) 264-3285  
E-Mail: legal@claytodayonline.com  
Christie Wayne christie@osteenmediagroup.com

## Notice of Meeting South Village Community Development District

The regular meeting of the Board of Supervisors of the South Village Community Development District will be held on Tuesday, January 7, 2025 at 6:30 p.m. at the Eagle Landing Residents Club, 3975 Eagle Landing Parkway, Orange Park, Florida 32065. The meeting is open to the public and will be conducted in accordance with the provisions of Florida Law for Community Development Districts. A copy of the agenda for this meeting may be obtained from the District Manager, at 475 West Town Place, Suite 114, St. Augustine, FL 32092 (and phone (904) 940-5850). This meeting may be continued to a date, time, and place to be specified on the record at the meeting.

Any person requiring special accommodations at this meeting because of a disability or physical impairment should contact the District Office at (904) 940-5850 at least two calendar days prior to the meeting. If you are hearing or speech impaired, please contact the Florida Relay Service at 1-800-955-8770, for aid in contacting the District Office.

Each person who decides to appeal any action taken at these meetings is advised that person will need a record of the proceedings and that accordingly, the person may need to ensure that a verbatim record of the proceedings is made, including the testimony and evidence upon which such appeal is to be based.

Marilee Giles  
District Manager  
Legal 132791 Published 12/26/2024 in Clay County's Clay Today newspaper

Disclosure Services LLC

1005 Bradford Way  
Kingston, TN 37763

# Invoice

Date	Invoice #
10/16/2024	28

Bill To
South Village CDD c/o GMS, LLC

Terms	Due Date
Net 30	11/15/2024

Description	Amount
Amortization Schedule Series 2016A-1 11-1-24 Prepay \$40,000	250.00
Amortization Schedule Series 2016A-2 11-1-24 Prepay \$15,000	100.00
Amortization Schedule Series 2016-3 11-1-24 Prepay \$5,000	100.00

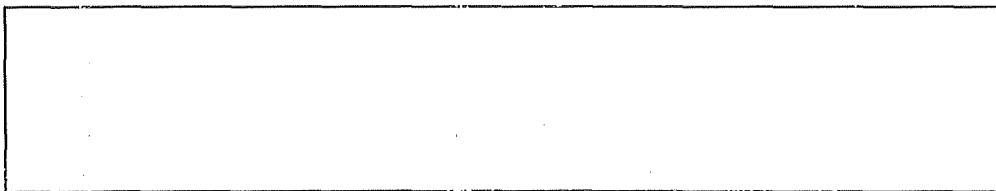

<b>Total</b>	\$450.00
<b>Payments/Credits</b>	\$0.00
<b>Balance Due</b>	\$450.00

Phone #
865-717-0976

E-mail
tcarter@disclosureservices.info

**Governmental Management Services, LLC**

475 West Town Place, Suite 114  
St. Augustine, FL 32092

**Invoice**

Invoice #: 318

Invoice Date: 1/1/25

Due Date: 1/1/25

Case:

P.O. Number:



**Bill To:**

South Village CDD  
475 West Town Place  
Suite 114  
St. Augustine, FL 32092

Description	Hours/Qty	Rate	Amount
Management Fees -January 2025	340	4,868.92	4,868.92
Information Technology -January 2025	351	168.50	168.50
Dissemination Agent Services -January 2025	313	795.92	795.92
Website Administration -January 2025	485	106.00	106.00
Office Supplies	510	8.72	8.72
Postage	420	0.69	0.69
Copies	415	22.80	22.80
Telephone	410	183.10	183.10
<b>Total</b>			<b>\$6,154.65</b>
<b>Payments/Credits</b>			<b>\$0.00</b>
<b>Balance Due</b>			<b>\$6,154.65</b>

 **The Lake Doctors, Inc.**  
Aquatic Management Services  
Post Office Box 20122  
Tampa, FL 33622-0122  
(904) 262-5500

**RETURN SERVICE REQUESTED**

PLEASE FILL OUT BELOW IF PAYING BY CREDIT CARD	
	
CARD NUMBER	EXP. DATE
SIGNATURE	AMOUNT PAID

**ADDRESSEE**

Please check if address below is incorrect and indicate change on return slip

12.1.3858 1 AB 0.588 44453S11 3858 3888 001/001 1



SOUTH VILLAGE CDD  
JAMES HAHN  
3989 EAGLE LANDING PKWY  
ORANGE PARK FL 32065-2641

ACCOUNT NUMBER	DATE	BALANCE
719371	12/16/2024	\$2,862.00

The Lake Doctors  
Post Office Box 20122  
Tampa, FL 33622-0122

00000000756950010000002327980000028620014

Please Return this portion with your payment and notify us of any changes to your contact informat

Invoice Due Date	12/12/2024	Invoice	232798B	PO #
------------------	------------	---------	---------	------

Date	Description	Quantity	Amount	Tax	Total
<b>Eagle Landing Parkway, Orange Park, FL Orange Park, FL 32065</b>					
12/2/2024	Water Management - Zone 1,Water Management - Zone 2,Water Management - Zone 3		\$954.00	\$0.00	\$954.00
			\$954.00	\$0.00	\$954.00
			\$954.00	\$0.00	\$954.00

# REPRINT OF OUTSTANDING INVOICE

*Handwritten notes:*  
\$2,862  
LAKELAND CONTACT  
1/3/25

Please provide remittance information when submitting payments, otherwise payments will be applied to the oldest outstanding invoices.

Credits	\$0.00
Adjustment	\$0.00

AMOUNT DUE

<b>Total Account Balance including this invoice:</b>	\$2862.00	<b>This Invoice Total:</b>	\$2862.00
--	-----------	----------------------------	-----------

To submit payment by ACH: Ameris Bank // Routing # 061201754 // Account # 2049360148

<b>Customer Account #:</b> 719371	<b>Corporate Address</b>
<b>Portal Registration #:</b> 2A40879A	4651 Salisbury Rd, Suite 155
	Jacksonville, FL 32256

**Customer Portal Link:** [www.lakedoctors.com/contact-us/](http://www.lakedoctors.com/contact-us/)

at Up Customer Portal to pay invoices online, set up recurring payments, view payment history, and edit contact information



MAKE CHECK PAYABLE TO:

PLEASE FILL OUT BELOW IF PAYING BY CREDIT CARD



Post Office Box 20122  
Tampa, FL 33622-0122  
(904) 262-5500

VISA		AMERICAN EXPRESS	
CARD NUMBER	EXP. DATE		
SIGNATURE		AMOUNT PAID	

ADDRESSEE

Please check if address below is incorrect and indicate change on reverse side

SOUTH VILLAGE CDD  
JAMES HAHN  
3989 Eagle Landing Pkwy  
Orange Park, FL 32065

ACCOUNT NUMBER	DATE	BALANCE
719371	1/2/2025	\$2,862.00

The Lake Doctors  
Post Office Box 20122  
Tampa, FL 33622-0122

000000007569500100000002400440000028620014

Please Return this invoice with your payment and notify us of any changes to your contact information.

<b>SOUTH VILLAGE CDD</b>	<b>Eagle Landing Parkway, Orange Park, FL</b>	<b>Orange Park, FL 32065</b>
<b>Invoice Due Date 1/11/2025</b>	<b>Invoice 240044B</b>	<b>PO #</b>

Invoice Date	Description	Quantity	Amount	Tax	Total
1/1/2025	Water Management - Zone 1, Water Management - Zone 2, Water Management - Zone 3		\$954.00	\$0.00	\$954.00
			\$954.00	\$0.00	\$954.00
			\$954.00	\$0.00	\$954.00

Please remit payment for this month's invoice.

*Handwritten notes:*  
 \$2,862.00  
 1/3/25  
 Lake Management Contact  
 General Fund

Please provide remittance information when submitting payments, otherwise payments will be applied to the oldest outstanding invoices.	<b>Credits</b>	\$0.00
	<b>Adjustment</b>	\$0.00
	<b>AMOUNT DUE</b>	

<b>Total Account Balance including this invoice:</b>	\$5724.00	<b>This Invoice Total:</b>	\$2862.00
--	-----------	----------------------------	-----------

Click the "Pay Now" link to submit payment by ACH

<b>Customer #:</b> 719371	<b>Corporate Address</b>
<b>Portal Registration #:</b> 2A40879A	4651 Salisbury Rd, Suite 155
<b>Customer E-mail(s):</b> JAMES.HAHN@HONOURSGOLF.COM, scott.swenson@honourgolf.com	Jacksonville, FL 32256
<b>Customer Portal Link:</b> www.lakedoctors.com/contact-us/	

Set Up Customer Portal to pay invoices online, set up recurring payments, view payment history, and edit contact information



**INVOICE**

Please Remit Payment to:  
 23601 Laytonville Road  
 Laytonville, MD 20882

Date	Invoice #
Dec 23, 2024	689551

James Hahn  
 South Village CDD  
 3989 Eagle Landing Parkway  
 Orange Park, FL 32065

Agreement with:  
 South Village CDD  
 3989 Eagle Landing Parkway  
 Orange Park, FL 32065

Property Name	Terms	Due Date	Order Number
Eagle Landing (261088)	Net 30 Days	Jan 23, 2025	4032724

QTY	Description	Price	Total
1	Install 3 Pallets of St. Augustine to repair area due to mainline break.  (3) pallets St. Augustine Sod Irrigation retro fitting for proper coverage of area  <i>Greater High Landscape</i> <i>\$1,922.00</i>  <i>[Signature]</i> <i>12/23/24</i>	\$1,922.00	\$1,922.00

For billing questions contact Tel: 904-778-1030

For customer service contact Kyle Carasea Tel: 813-293-0587

**Thank you for your business!**

<b>Subtotal:</b>	\$1,922.00
<b>Sales Tax:</b>	\$0.00
<b>Amount Due:</b>	\$1,922.00

Payment by Check or ACH is preferred. Banking details supplied by request. Invoices paid by Credit Card will be subject to a 3% processing fee to cover incurred charges.



**INVOICE**

Please Remit Payment to:  
 23601 Laytonsville Road  
 Laytonsville, MD 20882

Date	Invoice #
Dec 13, 2024	688968

**James Hahn**  
 South Village CDD  
 3989 Eagle Landing Parkway  
 Orange Park, FL 32065

**Agreement with:**  
 South Village CDD  
 3989 Eagle Landing Parkway  
 Orange Park, FL 32065

Property Name	Terms	Due Date	Order Number
Eagle Landing (261088)	Net 30 Days	Jan 12 2025	4026715

QTY	Description	Price	Total
1	Install (8) yards of flower bed soil to existing flower beds due to soil erosion to help with the overall growth and health of the flowers for Winter.  (8 yards Soil Amendment)	\$1,025.00	\$1,025.00

*Landscaping removal fee*  
*\$ 1,025*  
*SH*  
*12/23/24*

For billing questions contact Tel: 904-778-1030

For customer service contact Kyle Carasea Tel: 813-293-0587

<b>Subtotal:</b>	\$1,025.00
<b>Sales Tax:</b>	\$0.00
<b>Amount Due:</b>	\$1,025.00

**Thank you for your business!**



**INVOICE**

Please Remit Payment to:  
 23601 Laytonsville Road  
 Laytonsville, MD 20882

Date	Invoice #
Dec 13, 2024	688969

**James Hahn**  
 South Village CDD  
 3989 Eagle Landing Parkway  
 Orange Park, FL 32065

**Agreement with:**  
 South Village CDD  
 3989 Eagle Landing Parkway  
 Orange Park, FL 32065

Property Name	Terms	Due Date	Order Number
Eagle Landing (261088)	Net 30 Days	Jan 12, 2025	4028354

QTY	Description	Price	Total
1	Install Winter Flowers in 32 Planters Retro Fit Irrigation in Planters  (220) 4 or 4.5 Inch Winter Flowers Irrigation retro fitting emitters  <i>"Landscape General fund"</i> <i>\$1,550</i> <i>06</i> <i>12/23/24</i>	\$1,550.00	\$1,550.00

For billing questions contact Tel: 904-778-1030

For customer service contact Kyle Carasea Tel: 813-293-0587

<b>Subtotal:</b>	\$1,550.00
<b>Sales Tax:</b>	\$0.00
<b>Amount Due:</b>	\$1,550.00

**Thank you for your business!**





**INVOICE**

Date	Invoice#
Dec 31, 2024	690512

**Please Remit Payment to:**  
**23601 Laytonville Road**  
**Laytonville, MD 20882**

**James Hahn**  
**South Village CDD**  
**3989 Eagle Landing Parkway**  
**Orange Park, FL 32065**

**Agreement with:**  
**South Village CDD**  
**3989 Eagle Landing Parkway**  
**Orange Park, FL 32065**

Property Name	Terms	Due Date	Order Number
Eagle Landing (261088)	Net 30 Days	Jan 30, 2025	

Description	Price	Total
Landscape Management For December As Per Contract, Due Jan 30, 2025 Landscaping Maintenance Services SVCLD \$13,478.21 Landscaping Maintenance Services EL PH5 & 6 \$6,102.04	\$19,580.25	\$19,580.25

Landscape Contract  
 of  
 [Signature]  
 1/3/25  
 \$19,580.25

For billing questions contact Tel: 904-778-1030  
 For customer service contact Kyle Carasea Tel: 813-293-0597

**Thank you for your business!**

<b>Subtotal:</b>	<b>\$19,580.25</b>
<b>Sales Tax:</b>	<b>\$0.00</b>
<b>Amount Due:</b>	<b>\$19,580.25</b>

Payment by Check or ACH is preferred. Banking details supplied by request. Invoices paid by Credit Card will be subject to a 3% processing fee to cover incurred charges.



Please Remit Payment to:  
23601 Laytonsville Road  
Laytonsville, MD 20882

Date	Invoice #
Dec 31,2024	691617

**James Hahn**  
South Village CDD  
3989 Eagle Landing Parkway  
Orange Park, FL 32065

**Agreement with:**  
South Village CDD  
3989 Eagle Landing Parkway  
Orange Park, FL 32065

Property Name	Terms	Due Date	Order Number
Eagle Landing (261088)	Net 30 Days	Jan 30,2025	4047345

QTY	Description	Price	Total
1	Repaired 1" Mainline by pond in the area that the county did a repair, and replaced (2) Rotors.  (1) 1" Mainline (2) Rotors Labor	\$305.00	\$305.00

*Landscaping Contract*  
*1/14/25*  
*\$305.00*  
*[Signature]*

For billing questions contact Tel: 904-778-1030

For customer service contact Matthew D McNulty Tel: 999-999-9999

Subtotal:	\$305.00
Sales Tax:	\$0.00
Amount Due:	\$305.00

**Thank you for your business!**

Payment by Check or ACH is preferred. Banking details supplied by request. Invoices paid by Credit Card will be subject to a 3% processing fee to cover incurred charges.

CHECK DATE	VEND#	.....INVOICE..... DATE INVOICE	...EXPENSED TO... YRMO DPT ACCT# SUB SUBCLASS	VENDOR NAME	STATUS	AMOUNT	....CHECK..... AMOUNT #
1/31/25	00031	10/31/24 OCT 24 8966956 - 886 OAKLEAF	202410 320-57200-43000	CLAY ELECTRIC COOPERATIVE, INC.	*	201.86	201.86 080020
1/31/25	00231	11/30/24 NOV 24 NOV 24 - ELECTRIC	202411 320-57200-43000		*	1,710.34	
		11/30/24 NOV 24 NOV 24 - ELECTRIC	202411 320-57200-46600	CLAY ELECTRIC COOP (AUTOPAY)	*	566.39	2,276.73 080021
TOTAL FOR BANK Z						2,478.59	
TOTAL FOR REGISTER						39,233.59	

9I - South Village CDD dba Eagle Landing      Pg 1  
 A/P R - ACCOUNTS PAYABLE REC  
 Check Register for Jan 1/25 thru Jan 31/25  
 Regular Checks

Check	Issued to:	Date	Check Amount	Note
21594	CLAY ELECTRIC COOPERATIVE	Jan 3/25	4,067.00	
21595	DISCOVERY SERVICES LLC	Jan 9/25	195.00	
21596	SHARP ENERGY	Jan 9/25	764.93	
21597	10-S TENNIS SUPPLY	Jan 16/25	1,099.50	
21598	HOME DEPOT CREDIT SERVICES	Jan 16/25	1,467.14	
21599	POOLSURE	Jan 16/25	3,889.59	
21600	BOB S BACKFLOW & PLUMBING SERVICES	Jan 23/25	180.00	
21601	CLAY ELECTRIC COOPERATIVE	Jan 23/25	3,821.35	
21602	POOLSURE	Jan 23/25	89.42	
21603	SYSCO JACKSONVILLE INC	Jan 23/25	1,325.98	
21604	HOME DEPOT CREDIT SERVICES	Jan 30/25	1,756.61	
Total Regular Checks Issued			18,656.52	

===== End of Report =====

Member Name EAST WEST PARTNERS  
 Account # 6588982  
 Trustee District: 06  
 Statement Date: 12/08/2024  
 Current Bill Due Date: 12/27/2024

**Important Messages**

Miss your due date? Switch to to Auto Pay now - it's one and done. Monthly payments are automatically made with your bank account or credit card, and you'll still receive a monthly statement. Quick, easy and worry-free.

Total  
Amount Due

\$901.00

Due Date:  
12/27/2024

Previous Balance \$815.00  
 Payment Received 11/18/24 -\$815.00  
**Balance Forward \$0.00**  
 Current Charges Due 12/27/24 **\$901.00**

Service Address: 3965 EAGLE LANDING PKWY POOL PUMP HOUSE

Rate Schedule Description	Meter No.	Reading Dates		Readings		Multiplier	kWh Usage
		From	To	Previous	Present		
GENERAL SERVICE-NON DEMAND	152192769	11/04/24	12/05/24	14626	14816	40	7,600

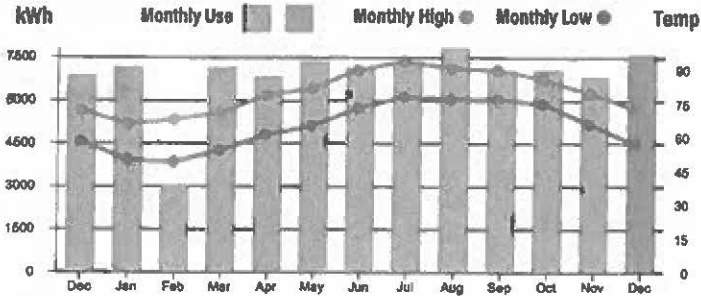

**Current Service Detail**

Access Charge		\$34.00
Energy Charge	7,600 kWh @ 0.0833	\$633.08
Power Cost Adjustment	7,600 kWh @ 0.0160	\$121.60
FLA Gross Receipts Tax		\$20.21
Florida State Sales Tax		\$58.22
Clay County Sales Tax		\$12.13
Clay Co Public Ser Utility Tax		\$22.96
Operation Round Up		\$0.80
<b>Total Current Charges for this Location</b>		<b>\$901.00</b>

2023 Please visit MyClayElectric for detailed usage history 2024

**This Month**    **Last Month**    **This Month Last Year**    **Avg Daily High**

7,600 kWh  
31 days  
Avg kWh 245

6,840 kWh  
31 days  
Avg kWh 221

6,880 kWh  
31 days  
Avg kWh 222

73°F

550-7200  
 [Signature]  
 12/23/24

**KEEP SEND** By accepting service from Clay Electric, you acknowledge that you have reviewed and accepted all of Clay Electric's Bylaws, Board policies and standards of service and agree to abide by them. Billing not paid in full will incur a late charge of \$5.00 or 6% of the delinquent amount (whichever is greater) that will be added to your account.

PO Box 308  
 Keystone Heights, FL 32656-0308

**PAY YOUR BILL 24/7**  
 ONLINE: Check or credit/debit card at ClayElectric.com or download the mobile app.



992 0 AV 0.545  
 EAST WEST PARTNERS  
 3989 EAGLE LANDING PKWY  
 ORANGE PARK FL 32065-2641

5 992  
 C-4

Account Number	6588982
Current Charges Due 12/27/24	\$901.00
<b>Total Amount Due</b>	<b>\$901.00</b>

Checks must be in U.S. funds and drawn on a U.S. bank.



**CLAY ELECTRIC COOPERATIVE**  
 PO BOX 308  
 KEYSTONE HEIGHTS, FL 32656-0308



06588982 0000901009

YYNY



Visit us online at ClayElectric.com  
Toll Free: (800)-224-4917

Member Name EAST WEST PARTNERS  
 Account # 6588990  
 Trustee District: 06  
 Statement Date: 12/06/2024  
 Current Bill Due Date: 12/27/2024

---

Previous Balance \$2,003.00  
 Payment Received 11/18/24 -\$2,003.00  
 Balance Forward \$0.00  
 Current Charges Due 12/27/24 \$1,443.00

### Important Messages

Miss your due date? Switch to to Auto Pay now - it's one and done. Monthly payments are automatically made with your bank account or credit card, and you'll still receive a monthly statement. Quick, easy and worry-free.

Total Amount Due

# \$1,443.00

Due Date:  
12/27/2024

Service Address: 3975 EAGLE LANDING PKWY RESIDENTS CLUB

Rate Schedule Description	Meter No.	Reading Dates		Readings		Multiplier	kWh Usage
		From	To	Previous	Present		
GENERAL SERVICE DEMAND	152192770	11/04/24	12/05/24	17176	17344	80	13,440

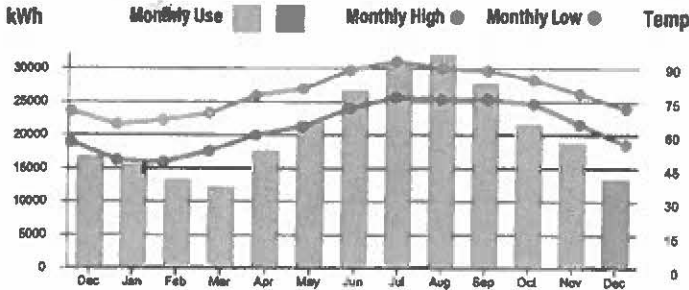

### Current Service Detail

Access Charge		\$80.00
Energy Charge	13,440 kWh @ 0.0600	\$806.40
Power Cost Adjustment	13,440 kWh @ 0.0160	\$215.04
Demand Charge	37.600 KW @ 4.3500	\$163.56
FLA Gross Receipts Tax		\$32.42
Florida State Sales Tax		\$90.17
Clay County Sales Tax		\$19.46
Clay Co Public Ser Utility Tax		\$35.41
Operation Round Up		\$0.54
<b>Total Current Charges for this Location</b>		<b>\$1,443.00</b>

2023 Please visit MyClayElectric for detailed usage history 2024

This Month      Last Month      This Month Last Year      Avg Daily High

13,440 kWh  
31 days  
Avg kWh 434

18,880 kWh  
31 days  
Avg kWh 609

16,800 kWh  
31 days  
Avg kWh 542

73°F

550-7800

APR 12/23/24

**KEEP SEND** By accepting service from Clay Electric, you acknowledge that you have reviewed and accepted all of Clay Electric's Bylaws, Board policies and standards of service and agree to abide by them. Billing not paid in full will incur a late charge of \$5.00 or 5% of the delinquent amount (whichever is greater) that will be added to your account.



PO Box 308  
Keystone Heights, FL 32656-0308

**PAY YOUR BILL 24/7**  
ONLINE: Check or credit/debit card at ClayElectric.com or download the mobile app.



EAST WEST PARTNERS  
3989 EAGLE LANDING PKWY  
ORANGE PARK FL 32065-0000

Account Number	6588990
Current Charges Due 12/27/24	\$1,443.00
Total Amount Due	\$1,443.00

Checks must be in U.S. funds and drawn on a U.S. bank.



CLAY ELECTRIC COOPERATIVE  
PO BOX 308  
KEYSTONE HEIGHTS, FL 32656-0308



06588990 0001443001

Member Name EAST WEST PARTNERS  
 Account # 6589006  
 Trustee District: 06  
 Statement Date: 12/06/2024  
 Current Bill Due Date: 12/27/2024

**Important Messages**

Miss your due date? Switch to Auto Pay now - it's one and done. Monthly payments are automatically made with your bank account or credit card, and you'll still receive a monthly statement. Quick, easy and worry-free.

Total Amount Due

\$1,723.00

Due Date:  
12/27/2024

Previous Balance \$2,010.00  
 Payment Received 11/18/24 -\$2,010.00  
 Balance Forward \$0.00  
 Current Charges Due 12/27/24 \$1,723.00

Service Address: 3979 EAGLE LANDING PKWY ATHLETIC CLUB

Rate Schedule Description	Meter No.	Reading Dates		Readings		Multiplier	kWh Usage
		From	To	Previous	Present		
GENERAL SERVICE DEMAND	152192772	11/04/24	12/05/24	13641	13803	80	12,960

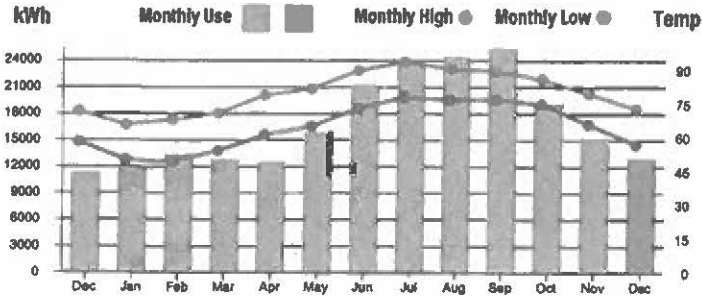

**Current Service Detail**

Access Charge		\$80.00
Energy Charge	12,960 kWh @ 0.0600	\$777.60
Power Cost Adjustment	12,960 kWh @ 0.0160	\$207.36
Demand Charge	101.760 KW @ 4.3500	\$442.68
FLA Gross Receipts Tax		\$38.63
Florida State Sales Tax		\$107.46
Clay County Sales Tax		\$23.19
Clay Co Public Ser Utility Tax		\$45.66
Operation Round Up		\$0.44
<b>Total Current Charges for this Location</b>		<b>\$1,723.00</b>

**This Month**      **Last Month**      **This Month Last Year**      **Avg Daily High**

12,960 kWh  
 31 days  
 Avg kWh  
 418

15,280 kWh  
 31 days  
 Avg kWh  
 493

11,360 kWh  
 31 days  
 Avg kWh  
 366

73°F

*low temp  
 85  
 12/23/24*

**KEEP SEND** By accepting service from Clay Electric, you acknowledge that you have reviewed and accepted all of Clay Electric's Bylaws, Board policies and standards of service and agree to abide by them. Billings not paid in full will incur a late charge of \$5.00 or 6% of the delinquent amount (whichever is greater) that will be added to your account.

PO Box 308  
 Keystone Heights, FL 32656-0308

**PAY YOUR BILL 24/7**  
 ONLINE: Check or credit/debit card at [ClayElectric.com](http://ClayElectric.com) or download the mobile app.



EAST WEST PARTNERS  
 3989 EAGLE LANDING PKWY  
 ORANGE PARK FL 32065-0000

Account Number	6589006
Current Charges Due 12/27/24	\$1,723.00
<b>Total Amount Due</b>	<b>\$1,723.00</b>

Checks must be in U.S. funds and drawn on a U.S. bank.



CLAY ELECTRIC COOPERATIVE  
 PO BOX 308  
 KEYSTONE HEIGHTS, FL 32656-0308





**DISCOVERY**  
**Services, LLC**  
 PO Box 1122  
 Middleburg, FL 32050

Discovery Services, LLC  
 PO Box 1122  
 Middleburg, FL 32050  
 904-695-8894

Invoice # 38398	
Invoice Date:	01/01/2025 Wednesday
Time:	12:00 PM
Bill-To:	102298
Location:	104034

South Village CDD - Master Account  
 3973 Eagle Landing Pkwy  
 Orange Park, FL 32065-2641

South Village CDD - Kids Club  
 3977 Eagle Landing Pkwy  
 Orange Park, FL 32065

Service Description	Quantity	Price
---------------------	----------	-------

Commercial Termite Bond Renewal	1.00	\$195.00
---------------------------------	------	----------

<b>SUBTOTAL</b>	<b>\$195.00</b>
<b>TAX</b>	<b>\$0.00</b>
<b>AMT PAID</b>	<b>\$0.00</b>
<b>TOTAL</b>	<b>\$195.00</b>
<b>PRIOR BAL</b>	<b>\$0.00</b>
<b>AMOUNT DUE</b>	<b>\$195.00</b>

*90-7440*  
*APR*  
*1/2/25*

Payment Receipt. Please Return with Payment Remittance

Bill-To: South Village CDD - Master Account  
 3973 Eagle Landing Pkwy  
 Orange Park, FL 32065-2641

Account #: 102298	Date: 01/01/2025
PO Number:	Invoice #: 38398
Terms: DUE ON RECEIPT	
Amount Paid:	_____
Check No.:	_____

Remit-To: Discovery Services, LLC  
 PO Box 1122  
 Middleburg, FL 32050  
 904-695-8894





REC

4613 Philips Hwy 208B Jacksonville, FL 32207  
(904)661-7590



Important Messages



Stay informed about the latest scams targeting consumers, get specific tips to recognize scammers and important guidelines that will help you act accordingly.

Go to [myaccountsharpenergy.com](http://myaccountsharpenergy.com) for more information on Propane Safety & Scam Awareness.

Safety Tip

If you are a will-call customer, remember to refill your propane tank before it reaches 25% capacity. If you are an automatic customer, your propane delivery will be scheduled as usual.

JOIN OUR ONLINE CUSTOMER PORTAL  
Payment Options Request Service Online  
24/7 Account Access Order Propane  
[myaccountsharpenergy.com](http://myaccountsharpenergy.com)

Invoice Information

Customer Name: EAGLE LANDING- POOL  
Account Number: 2036045  
Current Balance: \$764.93  
Invoice Date: 12/30/24  
Due Date: Upon Receipt  
Amount Due: \$1,815.33

Finance charge of 1.5% per month assessed on balances over 30 days  
Sharpgas, Inc. Fed# 51-0255314

Summary of Transactions

DATE	REF #	DESCRIPTION	AMOUNT
		PREVIOUS BALANCE	\$1,050.40
12/26/24	96416	BULK PROPANE JACKSONVILLE 245.6GALS@\$2.9657	\$728.38
12/26/24	96416	COUNTY UTILITY TAX	\$20.69
12/26/24	96416	FUEL SURCHARGE	\$3.90
12/26/24	96416	HAZMAT FEE /3973 EAGLE LANDING PARKWAY Y//ORANGE PARK FL 32065	\$11.96

Summary of Amount Due

Previous Balance	\$1,050.40
Current Transactions	\$764.93
<b>Amount Due:</b>	<b>\$1,815.33</b>

WARNING: (1) Over time, propane could experience odor fade. For your added safety, we recommend you consider purchasing and installing a propane detector. These can be found at most retail hardware stores. (2) Please be aware that there are unaffiliated bill pay websites that may represent themselves as Sharp Energy. To securely pay your bill online, please visit our website at [SharpEnergy.com](http://SharpEnergy.com).

Please bring entire invoice when paying in person.

Please detach and return this portion with your payment. Please do not staple, clip or attach check to the remittance payment coupon.

4613 Philips Hwy 208B  
Jacksonville, FL 32207  
Return Service Requested

550-7805  
APW  
1/7/25

\*\*INVOICE\*\*

2268000008 PRESORT PBPS001 <8>  
EAGLE LANDING- POOL  
ATTN: MATT BIAGETTI  
3973 EAGLE LANDING PKWY  
ORANGE PARK FL 32065-2641

Remittance Section

Account Number: 2036045  
Invoice Date: 12/30/24  
Due Date: Upon Receipt  
Amount Due: \$1,815.33  
Amount Paid: \$ \_\_\_\_\_

Please do not staple, clip or attach check to the remittance payment coupon. Make check payable to: Sharp Energy, Inc. Write your account number on your check. Save a stamp! Pay online at [www.SharpEnergy.com](http://www.SharpEnergy.com) Thank you!

SHARP ENERGY JACKSONVILLE  
PO BOX 829981  
PHILADELPHIA, PA 19182-9981





10-S Tennis Supply & Dinkshot Pickleball  
 1400 NW 13th Avenue  
 Pompano Beach, FL 33069  
 Toll-Free: (800) 247-3907  
 Local: (954) 969-5440  
 www.10-S.com / www.dinkshot.com

# Invoice

#167297

Date: 12/24/2024

**Bill To**  
 Tennis Center  
 Eagle Landing (Orange Park)  
 3979 Eagle Landing Pkwy  
 Orange Park FL 32065  
 United States

**Ship To**  
 Tennis Center  
 Eagle Landing (Orange Park)  
 3979 Eagle Landing Pkwy  
 Orange Park FL 32065  
 United States

Terms	Due Date	PO #	Sales Rep	Ship Via
Net 30	1/23/2025	Scott	Wendy Whaler	Best Way

Quantity	Item	Options	Customer Description	Rate	Amount
10	KW1004 Wilson US Open Reg Duty / Clay Court - Case of 72 balls			\$109.95	\$1,099.50

Subtotal	\$1,099.50
Shipping Costs (Best Way)	\$0.00
Tax (0%)	\$0.00
<b>Total</b>	<b>\$1,099.50</b>
Amount Paid	\$0.00
<b>Amount Due</b>	<b>\$1,099.50</b>

60-7681  
8

1/7/25  
1/14/25



167297



Commercial Account



Remit payment and make checks payable to:  
HOME DEPOT CREDIT SERVICES  
DEPT. 32 - 2639293211  
PO BOX 9001043  
LOUISVILLE, KY 40290-1043

# INVOICE DETAIL

**BILL TO:**  
Acct: 6035 3225 3929 3211  
SOUTH VILLAGE CDD

<b>Amount Due:</b>	<b>Trans Date:</b>	<b>DUE DATE:</b>	<b>Invoice #:</b>
\$67.86	12/06/24	02/28/25	6014289
<b>PO: GOLF</b>		<b>Store: 6935, MIDDLEBURG, FL</b>	

PRODUCT	SKU #	QUANTITY	UNIT PRICE	TOTAL PRICE
8 OUTLET PWR STRIP 4' RT ANGLE	00003358840000300005	1.0000 EA	\$7.88	\$7.88
7 FT. CANDY	10111843930001200072	1.0000 EA	\$79.00	\$79.00
DISCOUNT	00000000000000000005	1.0000 EA	-\$19.02	-\$19.02

Purchased by: SWENSON SCOTT  
Customer #: 00002

<b>SUBTOTAL</b>	\$67.86
<b>TAX</b>	\$0.00
<b>TOTAL</b>	\$67.86

**BILL TO:**  
Acct: 6035 3225 3929 3211  
SOUTH VILLAGE CDD

<b>Amount Due:</b>	<b>Trans Date:</b>	<b>DUE DATE:</b>	<b>Invoice #:</b>
\$72.97	12/10/24	02/28/25	2013358
<b>PO: GYM</b>		<b>Store: 6890, JACKSONVILLE, FL</b>	

PRODUCT	SKU #	QUANTITY	UNIT PRICE	TOTAL PRICE
ANGLE SLD STL 48X1 1/2X3/16	00004778740000400002	1.0000 EA	\$35.47	\$35.47
GREY FLECK RUBBER GYM FLOOR 26 IN X3	10059356030000200026	1.0000 LF	\$6.25	\$6.25
GREY FLECK RUBBER GYM FLOOR 26 IN X3	10059358030000200026	4.0000 LF	\$6.25	\$25.00
GREY FLECK RUBBER GYM FLOOR 26 IN X3	10059356030000200026	1.0000 LF	\$6.25	\$6.25

Purchased by: SWENSON SCOTT  
Customer #: 00002

<b>SUBTOTAL</b>	\$72.97
<b>TAX</b>	\$0.00
<b>TOTAL</b>	\$72.97

60112E





Commercial Account



Remit payment and make checks payable to: HOME DEPOT CREDIT SERVICES DEPT. 32 - 2539293211 PO BOX 9001049 LOUISVILLE, KY 40290-1043

# INVOICE DETAIL

**BILL TO:**  
Acct: 6035 3225 3929 3211  
SOUTH VILLAGE CDD

<b>Amount Due:</b>	<b>Trans Date:</b>	<b>DUE DATE:</b>	<b>Invoice #:</b>
\$309.00	11/18/24	01/31/25	4022049
<b>PO: TENNIS</b>		<b>Store: 6935, MIDDLEBURG, FL</b>	

PRODUCT	SKU #	QUANTITY	UNIT PRICE	TOTAL PRICE
HDX 27 GALLON TOUGH TOTE	00002075850001800002	1.0000 EA	\$9.98	\$9.98
HDX 27 GALLON TOUGH TOTE	00002075850001800002	1.0000 EA	\$9.98	\$9.98
HDX 27 GALLON TOUGH TOTE	00002075850001800002	1.0000 EA	\$9.98	\$9.98
6.5 FT FESTIVE PINE T2	10071244410001200010	1.0000 EA	\$49.98	\$49.98
6.5 FT FESTIVE PINE T2	10071244410001200010	1.0000 EA	\$49.98	\$49.98
HDX 27 GALLON TOUGH TOTE	00002075850001800002	1.0000 EA	\$9.98	\$9.98
6.5 FT FESTIVE PINE T2	10071244410001200010	1.0000 EA	\$49.98	\$49.98
DISCOUNT	00000000000000000005	1.0000 EA	-\$0.10	-\$0.10
6.5 FT FESTIVE PINE T2	10071244410001200010	1.0000 EA	\$49.98	\$49.98
UNB (60W) A19 SMT DL 16PK NDIM	10067779580000100035	1.0000 PK	\$19.97	\$19.97
UNB (60W) A19 SMT DL 16PK NDIM	10067779580000100035	1.0000 PK	\$19.97	\$19.97
MKE SHOCKWAVE 1/8"X3-1/2 CARBIDE BIT	10053983860000700008	1.0000 EA	\$4.67	\$4.67
MKE SHOCKWAVE 1/8"X3-1/2 CARBIDE BIT	10053983860000700008	1.0000 EA	\$4.67	\$4.67
ASOTV OVER LITE ULTRA	10044442020000100025	1.0000 EA	\$19.98	\$19.98

**Purchased by:** SWENSON SCOTT  
**Customer #:** 00002

<b>SUBTOTAL</b>	\$309.00
<b>TAX</b>	\$0.00
<b>TOTAL</b>	\$309.00

60-7452  
8  
APC

**BILL TO:**  
Acct: 6035 3225 3929 3211  
SOUTH VILLAGE CDD

<b>Amount Due:</b>	<b>Trans Date:</b>	<b>DUE DATE:</b>	<b>Invoice #:</b>
\$184.40	11/19/24	01/31/25	3011665
<b>PO: TANSTONE</b>		<b>Store: 6890, JACKSONVILLE, FL</b>	

PRODUCT	SKU #	QUANTITY	UNIT PRICE	TOTAL PRICE
SHELF BRACKET_LD_5" X 6" WH	00007086050000400014	1.0000 EA	\$1.93	\$1.93
SHELF BRACKET_LD_5" X 6" WH	00007086050000400014	1.0000 EA	\$1.93	\$1.93
SHELF BRACKET_LD_5" X 6" WH	00007086050000400014	1.0000 EA	\$1.93	\$1.93
SHELF BRACKET_LD_5" X 8" WH	00007086050000400014	1.0000 EA	\$1.93	\$1.93
22' MULTI POSITION LADDER 300LB DUTY	10048876070000800008	1.0000 EA	\$239.00	\$239.00
SHELF BRACKET_LD_5" X 6" WH	00007086050000400014	1.0000 EA	\$1.93	\$1.93
DISCOUNT	00000000000000000005	1.0000 EA	-\$90.00	-\$90.00
SHELF BRACKET_LD_5" X 6" WH	00007086050000400014	1.0000 EA	\$1.93	\$1.93
USG AP LIGHT DUST CONTROL 3.5QT PAIL	10013821510001200003	1.0000 EA	\$10.88	\$10.88
MD 81" VYL CLAD REPL WS-BGE	00005974830000400009	1.0000 EA	\$6.47	\$6.47
MD 81" VYL CLAD REPL WS-BGE	00005974830000400009	1.0000 EA	\$6.47	\$6.47

**Purchased by:** SWENSON SCOTT  
**Customer #:** 00002

<b>SUBTOTAL</b>	\$184.40
<b>TAX</b>	\$0.00
<b>TOTAL</b>	\$184.40

60-7452  
8  
APC

**BILL TO:**  
Acct: 6035 3225 3929 3211  
SOUTH VILLAGE CDD

<b>Amount Due:</b>	<b>Trans Date:</b>	<b>DUE DATE:</b>	<b>Invoice #:</b>
\$227.09	11/19/24	01/31/25	3012490
<b>PO: GOLF</b>		<b>Store: 6935, MIDDLEBURG, FL</b>	

PRODUCT	SKU #	QUANTITY	UNIT PRICE	TOTAL PRICE
6-1/2" STEEL T-POST 1.25	00001756440001300004	1.0000 EA	\$8.21	\$8.21
#036 SS CLAMP 1-3/4"X2-3/4" DIA	00001004940000600024	1.0000 EA	\$3.18	\$3.18
#036 SS CLAMP 1-3/4"X2-3/4" DIA	00001004940000600024	1.0000 EA	\$3.18	\$3.18
#036 SS CLAMP 1-3/4"X2-3/4" DIA	00001004940000600024	1.0000 EA	\$3.18	\$3.18
1X10 PIPE	00003013370000100006	1.0000 EA	\$35.51	\$35.51
1X10 PIPE	00003013370000100006	1.0000 EA	\$35.51	\$35.51

continued →





Commercial Account



Remit payment and make checks payable to: HOME DEPOT CREDIT SERVICES DEPT. 32 - 2539293211 PO BOX 9001043 LOUISVILLE, KY 40290-1043

# INVOICE DETAIL

BILL TO:  
Acct: 6035 3225 3929 3211  
SOUTH VILLAGE CDD

Amount Due:	Trans Date:	DUE DATE:	Invoice #:
\$287.85	11/26/24	01/31/25	6012265
PO: TENECE		Store: 6890, JACKSONVILLE, FL	

PRODUCT	SKU #	QUANTITY	UNIT PRICE	TOTAL PRICE
CE 8" NATURAL CABLE TIE 100PK	00002956480001100005	1.0000 BG	\$10.98	\$10.98
1.5 CF MG ORGANIC NATURAL MULCH	10103623750001900003	1.0000 BG	\$3.97	\$3.97
1.5 CF MG ORGANIC NATURAL MULCH	10103623750001900003	1.0000 BG	\$3.97	\$3.97
1.5 CF MG ORGANIC NATURAL MULCH	10103623750001900003	1.0000 BG	\$3.97	\$3.97
CUTTER BACKWOODS AEROS TWIN PK 6OZ	00001648290000100025	1.0000 EA	\$9.97	\$9.97
3/4ODX1/2IDX10" BR VINYL TUBE	00002046980000100028	1.0000 EA	\$17.98	\$17.98
RYB 18V HP BL PET STICK VACUUM KIT	10074736010001600005	1.0000 EA	\$249.00	\$249.00
1/2" BARB X 3/4" MIP ADAPTER NYLON	00008915310000100025	1.0000 EA	\$2.85	\$2.85
DISCOUNT	00000000000000000005	1.0000 EA	-\$50.00	-\$50.00
1/2" BARB X 3/4" MIP ADAPTER NYLON	00008915310000100025	1.0000 EA	\$2.85	\$2.85
VIGORO ANCHORING SPIKES - 8PK	10000237280002300010	1.0000 EA	\$6.47	\$6.47
93MASTERKEY	00005337480000500003	1.0000 EA	\$3.97	\$3.97
93MASTERKEY	00005337480000500003	1.0000 EA	\$3.97	\$3.97
93MASTERKEY	00005337480000500003	1.0000 EA	\$3.97	\$3.97
93MASTERKEY	00005337480000500003	1.0000 EA	\$3.97	\$3.97
HDX 15FT 16/3 EXTENSION CORD WHT	10013760940000300003	1.0000 EA	\$9.98	\$9.98

Purchased by: SWENSON SCOTT  
Customer #: 00002

SUBTOTAL	\$287.85
TAX	\$0.00
TOTAL	\$287.85

*Handwritten initials and scribbles over the invoice items.*

201107E

BILL TO:  
Acct: 6035 3225 3929 3211  
SOUTH VILLAGE CDD

Amount Due:	Trans Date:	DUE DATE:	Invoice #:
\$341.59	12/03/24	02/28/25	9013952
PO: GYM		Store: 6935, MIDDLEBURG, FL	

PRODUCT	SKU #	QUANTITY	UNIT PRICE	TOTAL PRICE
LAVENDER SCE	10075235660000400011	1.0000 EA	\$14.97	\$14.97
ENERGIZER MAX AAA 30-PACK	10025808830003600002	1.0000 EA	\$20.87	\$20.87
OUTTIME15AMP	10078126510003100003	1.0000 EA	\$11.98	\$11.98
OUTTIME15AMP	10078126510003100003	1.0000 EA	\$11.98	\$11.98
TWIST AND SEAL CORD PROTECT GREEN	10018445950000300009	1.0000 EA	\$5.97	\$5.97
TWIST AND SEAL CORD PROTECT GREEN	10018445950000300009	1.0000 EA	\$5.97	\$5.97
15FT 16/3 WORKSHOP EXT CORD BLK	10013636880000300003	1.0000 EA	\$9.98	\$9.98
SWIFFER DUSTER 180 RFL UNSCNT 18CT	10027766190000400011	1.0000 EA	\$15.97	\$15.97
15FT 16/3 WORKSHOP EXT CORD BLK	10013636880000300003	1.0000 EA	\$9.98	\$9.98
DISCOUNT	00000000000000000005	1.0000 EA	-\$30.00	-\$30.00
ONE+ 18-VOLT	10081423180001600005	1.0000 EA	\$149.00	\$149.00
HDX 2FT. 14/3 BL FAN TAP ADAPTER	10091271440000300003	1.0000 EA	\$9.98	\$9.98
HDX 15FT 16/3 EXTENSION CORD WHT	10013760940000300003	1.0000 EA	\$9.98	\$9.98
HDX 15FT 16/3 EXTENSION CORD WHT	10013760940000300003	1.0000 EA	\$9.98	\$9.98
RYOBI 18V 8IN POLE SAW TOOL ONLY	10074719630003200023	1.0000 EA	\$129.00	\$129.00
FABULOSO ANTIBAC LAV 169OZ	10077915190000400004	1.0000 EA	\$11.98	\$11.98
DISCOUNT	00000000000000000005	1.0000 EA	-\$6.00	-\$6.00

continued →





Commercial Account



Remit payment and make checks payable to:  
HOME DEPOT CREDIT SERVICES  
DEPT. 32 - 2539293211  
PO BOX 9001043  
LOUISVILLE, KY 40290-1043

# INVOICE DETAIL

Invoice #:  
**9013952**  
continued

PRODUCT	SKU #	QUANTITY	UNIT PRICE	TOTAL PRICE
DISCOUNT	00000000000000000000	1.0000 EA	-\$50.00	-\$50.00

Purchased by: SWENSON SCOTT  
Customer #: 00002

<b>SUBTOTAL</b>	\$341.59
<b>TAX</b>	\$0.00
<b>TOTAL</b>	<b>\$341.59</b>

BILL TO:  
Acct: 6035 3225 3929 3211  
SOUTH VILLAGE CDD

<b>Amount Due:</b>	<b>Trans Date:</b>	<b>DUE DATE:</b>	<b>Invoice #:</b>
\$271.33	12/04/24	02/28/25	<b>8014079</b>
<b>PO: GOLF</b>		<b>Store: 6935, MIDDLEBURG, FL</b>	

PRODUCT	SKU #	QUANTITY	UNIT PRICE	TOTAL PRICE
1 PVC CPLG	00001880850000100003	1.0000 EA	\$0.87	\$0.87
1 PVC CPLG	00001880850000100003	1.0000 EA	\$0.87	\$0.87
36" WATER METER VALVE KEY	10050483790000700009	1.0000 EA	\$19.98	\$19.98
1 PVC CPLG	00001880850000100003	1.0000 EA	\$0.87	\$0.87
1 PVC CPLG	00001880850000100003	1.0000 EA	\$0.87	\$0.87
AMERIGAS PROPANE EXCHANGE	00006003720002200004	7.0000 EA	\$21.98	\$153.86
GREAT STUFF GAPS & CRACKS	00001381420000400005	1.0000 EA	\$4.38	\$4.38
12OZ				
1"X 10' PVC40 PE PIPE	00001937650000100002	1.0000 EA	\$8.48	\$8.48
PLC 59W 8FT T8 COOL WHITE 1PK	00004003480000100036	1.0000 EA	\$16.98	\$16.98
PLC 59W 8FT T8 COOL WHITE 1PK	00004003480000100036	1.0000 EA	\$16.98	\$16.98
PLC 59W 8FT T8 COOL WHITE 1PK	00004003480000100036	1.0000 EA	\$16.98	\$16.98
PLC 59W 8FT T8 COOL WHITE 1PK	00004003480000100036	1.0000 EA	\$16.98	\$16.98
8 OZ. RAIN R SHINE PURPLE PRIMER	10046627370000100021	1.0000 EA	\$13.23	\$13.23
HAN				

Purchased by: SWENSON SCOTT  
Customer #: 00002

<b>SUBTOTAL</b>	\$271.33
<b>TAX</b>	\$0.00
<b>TOTAL</b>	<b>\$271.33</b>

BILL TO:  
Acct: 6035 3225 3929 3211 1460-000 -200  
SOUTH VILLAGE CDD 1470-000 200

<b>Amount Due:</b>	<b>Trans Date:</b>	<b>DUE DATE:</b>	<b>Invoice #:</b>
\$343.48	12/06/24	02/28/25	<b>6014288</b>
<b>PO: GOLF</b>		<b>Store: 6935, MIDDLEBURG, FL</b>	

PRODUCT	SKU #	QUANTITY	UNIT PRICE	TOTAL PRICE
BRASS 69 KEY MASTER PADLOCK	00005333450000500003	1.0000 EA	\$3.97	\$3.97
BRASS 69 KEY MASTER PADLOCK	00005333450000500003	1.0000 EA	\$3.97	\$3.97
BRASS 69 KEY MASTER PADLOCK	00005333450000500003	1.0000 EA	\$3.97	\$3.97
BRASS 69 KEY MASTER PADLOCK	00005333450000500003	1.0000 EA	\$3.97	\$3.97
AMERIGAS PROPANE EXCHANGE	00006003720002200004	6.0000 EA	\$21.98	\$131.88
BRASS 69 KEY MASTER PADLOCK	00005333450000500003	1.0000 EA	\$3.97	\$3.97
1X2X8 FVRR	00001609540000500011	10.0000 EA	\$1.57	\$15.70
BRASS 69 KEY MASTER PADLOCK	00005333450000500003	1.0000 EA	\$3.97	\$3.97
TEKS LATH SHARP PT SCREW 8X1	00001851750000300008	1.0000 EA	\$12.77	\$12.77
170PK				
WISE GRIP LEVER DIVERTER	00003442830000700002	1.0000 EA	\$9.37	\$9.37
HANDLE				
CE WALL PACK LIGHT 1450L	10111852650001800036	1.0000 EA	\$49.97	\$49.97
FEIT 5" LED LS D2D WALL PK 5CCT	10111852650001800036	1.0000 EA	\$99.97	\$99.97
BZ				

Purchased by: SWENSON SCOTT  
Customer #: 00002

<b>SUBTOTAL</b>	\$343.48
<b>TAX</b>	\$0.00
<b>TOTAL</b>	<b>\$343.48</b>

901108







# Invoice

Date Invoice#

1/1/2025  
131295626443

1707 Townhurst Dr.  
Houston TX 77043  
(800) 858-POOL (7665)  
www.poolsure.com

Terms	Net 30
Due Date	1/31/2025
PO #	

<b>Bill To</b>
Honours Golf 3989 Eagle Landing Parkway Orange Park FL 32065

<b>Ship To</b>
South Village CDD 3975 Eagle Landing Pkwy Orange Park FL 32065

Save in 2025 by prepaying your annual amount. Customers who prepay for 2025 by 12/31/2024 will receive a 5% discount on their annual rate. Contact ar@poolsure.com and request your 2025 annual invoice.

LATE FEE: This constitutes notice under the truth in lending act that any accounts remaining unpaid after the due date are subject to 1 1/2% per month late charge and attorney fees

Item	Description	Qty	Units	Amount
	Water Management Flat Billing Rate	1	ea	\$3,889.59

Subtotal	\$3,889.59
Tax	\$0.00
<b>Total</b>	<b>\$3,889.59</b>
Amount Paid/Credit Applied	\$0.00
<b>Balance Due</b>	<b>\$3,889.59</b>

550-7785  
to  
[Signature]  
1/1/25



131295626443

**Bob's Backflow & Plumbing Services**

4640 Subchaser Ct., Ste 113  
 Jacksonville, FL 32244

Phone # (904) 268-8009

Fax # (904) 292-4403

**INVOICE**

18637

Invoice Date

1/6/2025

<b>Bill To</b>
Eagle Landing HOA c/o GMS/Governmental Mgmt Svcs Inc 475 West Town Place Suite 114 St Augustine, FL 32092

<b>Job Location</b>
Eagle Landing HOA Various addresses Orange Park, Fl. 32065



P.O. Number	Terms	Due Date
	Net 30	2/5/2025

Serviced	Description	Quantity	Price Each	Amount
1/3/2025	4045-2 Eagle Landing Pkwy			
	1" Apollo RPLF4A Serial# 812845 Labor to flush and clean #1 check assembly, and restore service	2	90.00	180.00

900-7440  
 S  
 PK  
 1/7/25

**Thank you for your business. We appreciate your prompt payment.**  
 Please make checks payable to Bob's Backflow and include your invoice number.

<b>Total</b>	\$180.00
<b>Payments/Credits</b>	\$0.00
<b>Balance Due</b>	\$180.00





Visit us online at [ClayElectric.com](http://ClayElectric.com)  
Toll Free: (800)-224-4917

**Member Name** EAST WEST PARTNERS  
**Account #** 6588982  
**Trustee District:** 06  
**Statement Date:** 01/08/2025  
**Current Bill Due Date:** 01/29/2025

**Important Messages**

With the cold weather, your electric bill this month may reflect higher than normal energy usage. Setting your thermostat to 68 degrees or lower is recommended for the winter months. You can track your energy use, set usage alerts and more in your MyClayElectric account.



Previous Balance	\$901.00
Payment Received 01/06/25	-\$901.00
Late Charge	\$45.05
<b>Past Due Balance</b>	<b>\$45.05</b>
<b>Current Charges Due 01/29/25</b>	<b>\$836.00</b>

7800-550 836.00  
7581-800 45.05

**Service Address: 3965 EAGLE LANDING PKWY POOL PUMP HOUSE**

Rate Schedule Description	Meter No.	Reading Dates		Readings		Multiplier	kWh Usage
		From	To	Previous	Present		
GENERAL SERVICE-NON DEMAND	152192769	12/05/24	01/04/25	14816	14992	40	7,040

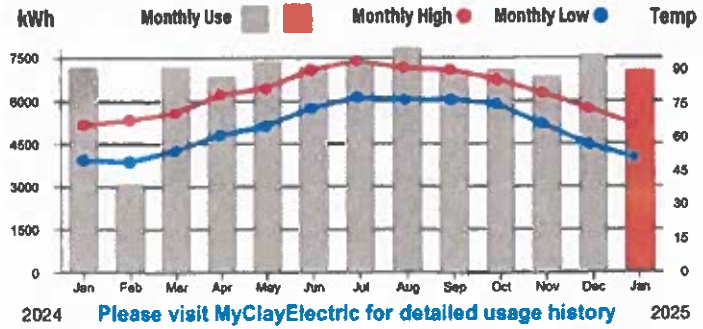

**Current Service Detail**

Access Charge		\$34.00
Energy Charge	7,040 kWh @ 0.0833	\$586.43
Power Cost Adjustment	7,040 kWh @ 0.0160	\$112.84
FLA Gross Receipts Tax		\$18.79
Florida State Sales Tax		\$52.25
Clay County Sales Tax		\$11.28
Clay Co Public Ser Utility Tax		\$20.18
Operation Round Up		\$0.43
<b>Total Current Charges for this Location</b>		<b>\$836.00</b>

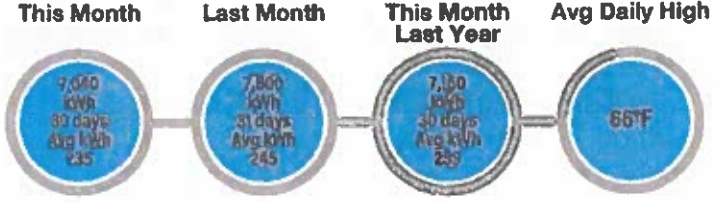

**KEEP SEND** By accepting service from Clay Electric, you acknowledge that you have reviewed and accepted all of Clay Electric's Bylaws, Board policies and standards of service and agree to abide by them. Billings not paid in full will incur a late charge of \$5.00 or 5% of the delinquent amount (whichever is greater) that will be added to your account.



<b>Account Number</b>	<b>6588982</b>
<b>Past Due Balance</b>	<b>\$45.05</b>
<b>Current Charges Due 01/29/25</b>	<b>\$836.00</b>
<b>Total Amount Due</b>	<b>\$881.05</b>

Checks must be in U.S. funds and drawn on a U.S. bank.



**CLAY ELECTRIC COOPERATIVE**  
PO BOX 308  
KEYSTONE HEIGHTS, FL 32656-0308



987 0 AV 0.545  
EAST WEST PARTNERS  
3989 EAGLE LANDING PKWY  
ORANGE PARK FL 32065-2641

5 987  
C-4



06588982 0000881052

**Member Name** EAST WEST PARTNERS  
**Account #** 6588990  
**Trustee District:** 06  
**Statement Date:** 01/08/2025  
**Current Bill Due Date:** 01/29/2025

**Important Messages**

With the cold weather, your electric bill this month may reflect higher than normal energy usage. Setting your thermostat to 68 degrees or lower is recommended for the winter months. You can track your energy use, set usage alerts and more in your MyClayElectric account.

Total Amount Due

# \$1,473.15

Due Date: 01/29/2025

Previous Balance \$1,443.00  
 Payment Received 01/06/25 -\$1,443.00  
 Late Charge \$72.15

**Past Due Balance \$72.15**

**Current Charges Due 01/29/25 \$1,401.00**

**Past Due Balance of \$72.15 is subject to late fee, disconnection, and/or deposit if not paid by 01/17/2025.**

7800-550 1,401.00  
 7581-800 72.15

**Service Address: 3975 EAGLE LANDING PKWY RESIDENTS CLUB**

Rate Schedule Description	Meter No.	Reading Dates		Readings		Multiplier	kWh Usage
		From	To	Previous	Present		
GENERAL SERVICE DEMAND	152192770	12/05/24	01/04/25	17344	17508	80	13,120

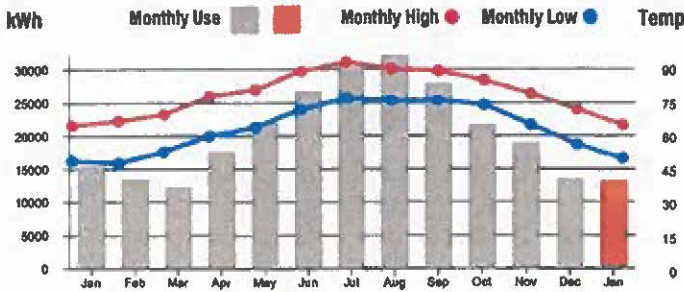

Access Charge		\$80.00
Energy Charge	13,120 kWh @ 0.0600	\$787.20
Power Cost Adjustment	13,120 kWh @ 0.0160	\$209.92
Demand Charge	35.200 KW @ 4.3500	\$153.12
FLA Gross Receipts Tax		\$31.53
Florida State Sales Tax		\$87.69
Clay County Sales Tax		\$18.93
Clay Co Public Ser Utility Tax		\$32.17
Operation Round Up		\$0.44
<b>Total Current Charges for this Location</b>		<b>\$1,401.00</b>

2024 Please visit MyClayElectric for detailed usage history 2025

This Month	Last Month	This Month Last Year	Avg Daily High
13,120 kWh 30 days Avg kWh 437	13,440 kWh 31 days Avg kWh 434	16,600 kWh 30 days Avg kWh 553	66°F

**KEEP SEND**  
 By accepting service from Clay Electric, you acknowledge that you have reviewed and accepted all of Clay Electric's Bylaws, Board policies and standards of service and agree to abide by them. Billings not paid in full will incur a late charge of \$5.00 or 5% of the delinquent amount (whichever is greater) that will be added to your account.

PO Box 308  
 Keystone Heights, FL 32656-0308

**PAY YOUR BILL 24/7**  
**ONLINE:** Check or credit/debit card at ClayElectric.com or download the mobile app.



<b>Account Number</b>	6588990
<b>Past Due Balance</b>	\$72.15
<b>Current Charges Due 01/29/25</b>	\$1,401.00
<b>Total Amount Due</b>	\$1,473.15

Checks must be in U.S. funds and drawn on a U.S. bank.



**CLAY ELECTRIC COOPERATIVE**  
 PO BOX 308  
 KEYSTONE HEIGHTS, FL 32656-0308



**EAST WEST PARTNERS**  
 3989 EAGLE LANDING PKWY  
 ORANGE PARK FL 32065-0000



**Member Name** EAST WEST PARTNERS  
**Account #** 6589006  
**Trustee District:** 06  
**Statement Date:** 01/08/2025  
**Current Bill Due Date:** 01/29/2025

**Important Messages**

With the cold weather, your electric bill this month may reflect higher than normal energy usage. Setting your thermostat to 68 degrees or lower is recommended for the winter months. You can track your energy use, set usage alerts and more in your MyClayElectric account.

**Total Amount Due**  
\$1,467.15  
**Due Date:**  
 01/29/2025

Previous Balance \$1,723.00  
 Payment Received 01/06/25 -\$1,723.00  
 Late Charge \$86.15  
**Past Due Balance \$86.15**

**Current Charges Due 01/29/25 \$1,381.00**

**Past Due Balance of \$86.15 is subject to late fee, disconnection, and/or deposit if not paid by 01/17/2025.**

7800-600 1,381.00  
 7581-800 86.15

**Service Address: 3979 EAGLE LANDING PKWY ATHLETIC CLUB**

Rate Schedule Description	Meter No.	Reading Dates		Readings		Multiplier	kWh Usage
		From	To	Previous	Present		
GENERAL SERVICE DEMAND	152192772	12/05/24	01/04/25	13803	13925	80	9,760

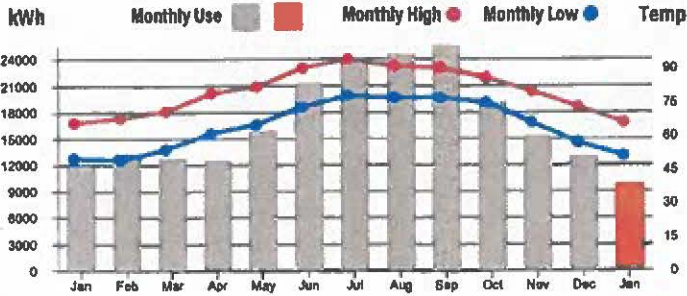

**Current Service Detail**

Access Charge		\$80.00
Energy Charge	9,760 kWh @ 0.0600	\$585.60
Power Cost Adjustment	9,760 kWh @ 0.0160	\$156.16
Demand Charge	89.120 KW @ 4.3500	\$387.67
FLA Gross Receipts Tax		\$31.00
Florida State Sales Tax		\$86.21
Clay County Sales Tax		\$18.61
Clay Co Public Ser Utility Tax		\$35.70
Operation Round Up		\$0.05
<b>Total Current Charges for this Location</b>		<b>\$1,381.00</b>

2024 [Please visit MyClayElectric for detailed usage history](#) 2025

**This Month**    **Last Month**    **This Month Last Year**    **Avg Daily High**

9,760 kWh  
 30 days  
 Avg kWh  
 325

12,980 kWh  
 31 days  
 Avg kWh  
 418

11,750 kWh  
 30 days  
 Avg kWh  
 392

66°F

**KEEP SEND** By accepting service from Clay Electric, you acknowledge that you have reviewed and accepted all of Clay Electric's Bylaws, Board policies and standards of service and agree to abide by them. Billing not paid in full will incur a late charge of \$5.00 or 6% of the delinquent amount (whichever is greater) that will be added to your account.

PO Box 308  
 Keystone Heights, FL 32656-0308

**PAY YOUR BILL 24/7**  
 ONLINE: Check or credit/debit card at ClayElectric.com or download the mobile app.



EAST WEST PARTNERS  
 3989 EAGLE LANDING PKWY  
 ORANGE PARK FL 32065-0000

<b>Account Number</b>	<b>6589006</b>
<b>Past Due Balance</b>	<b>\$86.15</b>
<b>Current Charges Due 01/29/25</b>	<b>\$1,381.00</b>
<b>Total Amount Due</b>	<b>\$1,467.15</b>

Checks must be in U.S. funds and drawn on a U.S. bank.



**CLAY ELECTRIC COOPERATIVE**  
 PO BOX 308  
 KEYSTONE HEIGHTS, FL 32656-0308





# Statement

Date

1/1/2025

7581-800

**Bill To**

Honours Golf  
 3989 Eagle Landing Parkway  
 Orange Park FL 32065

Date	Due Date	Description	Bill To / Location	Amount	Credit/Pymt	Open Amt	Balance												
5/31/2020	12/31/2099	Finance Charge #131295593082		29.48		29.48	29.48												
6/30/2020	12/31/2099	Finance Charge #131295593868		29.48		29.48	58.96												
7/31/2020	12/31/2099	Finance Charge #131295594550		30.46		30.46	89.42												
12/1/2024	12/31/2024	Invoice #131295626074	Eagle's Landing / South Village C...	3,704.37		3,704.37	3,793.79												
1/1/2025	1/31/2025	Invoice #131295626443	Eagle's Landing / South Village C...	3,889.59		3,889.59	7,683.38												
<table border="1"> <thead> <tr> <th>Current</th> <th>1-30 Days</th> <th>31-60 Days</th> <th>61-90 Days</th> <th>Over 90 Days</th> <th>Amount Due</th> </tr> </thead> <tbody> <tr> <td>3,889.59</td> <td>0.00</td> <td>3,704.37</td> <td>0.00</td> <td>89.42</td> <td>\$7,683.38</td> </tr> </tbody> </table>								Current	1-30 Days	31-60 Days	61-90 Days	Over 90 Days	Amount Due	3,889.59	0.00	3,704.37	0.00	89.42	\$7,683.38
Current	1-30 Days	31-60 Days	61-90 Days	Over 90 Days	Amount Due														
3,889.59	0.00	3,704.37	0.00	89.42	\$7,683.38														



REC

CUSTOMER'S ORIGINAL INVOICE CONFIDENTIAL PROPERTY OF SYSCO

EAGLE LANDING SWIM TENNIS  
3975 EAGLE LANDING PKWY  
ORANGE PARK FL 32065



SYSCO JACKSONVILLE, INC.  
1501 LEWIS INDUSTRIAL DRIVE  
JACKSONVILLE, FL 32254  
1-800-797-2627 (1-800 SYSCO CS

904-291-4343

EAGLE LANDING GOLF CLUB  
3989 EAGLE LANDING PKWY  
ORANGE PARK FL 32065 -2641

DELIV. DATE	CUSTOMER	INVOICE NUMBER	PAGE
1/04/25			
TRUCK STOP	496745	583034925	3 2
621/003			
ROUTE	PURCHASE ORDER		
6637	TERMS -PAST DUE BALANCES ARE SUBJECT TO SERVICE CHARGE		
	Net 30		
	MANIFEST# 1276541 NORMAL DELIVERY		
	MA: TVADC SCARLETT BAYLESS		

DRIVER:

QTY	PACK	SIZE	ITEM DESCRIPTION	ITEM CODE	UNIT PRICE	UNIT TAX AMOUNT	EXTENDED PRICE	TAX	INVOICE ADJUSTMENTS		
									CODE	QTY	
D 3	CS	2420 OZ	GATRADE DRINK ORANGE WIDEMOUT 10052000328674	7468556	29.84		89.52				
D 3	CS	2420 OZ	GATRADE DRINK RASP COOL BLUE 10052000324812	7468531	29.84		89.52				
D 1	CS	2410 OZ	SCHWEPP SODA CLUB 1660-51472	4381158	22.21		22.21				
D 2	CS	2412 OZ	COCACOL SODA COCA COLA CLS 49000012781	2786127	18.71		37.42				
D 3	CS	2412 OZ	COCACOL SODA COKE DIET 49000010633	4187357	18.71		56.13				
D 1	CS	2412 OZ	MTN DEW SODA MOUNTAIN DEW 44358	4743621	16.40		16.40				
D 3	CS	2412 OZ	PEPSI SODA PEPSI 00017	4146379	16.40		49.20				
D 3	CS	2412 OZ	SPRITE SODA SPRITE CANS 49000001310	5360359	18.71		56.13				
D 1	CS	2410 OZ	SCHWEPP SODA TONIC WATER 50570	4099891	22.16		22.16				
D 6	CS	4016.90Z	NIAGARA WATER BOTTLED DRINKING NDW05L40PDR	9901029	13.19		79.14				
							GROUP TOTAL****	1052.03			
							***PAPER & DISP***				
D 1	CS	1557 CT	SYS REL CUP PLAS TRANS HIPS 12 OZ YE12SYSA	7064580	38.21		38.21				
D 2	CS	10100 CTS	SYS CLS GLOVE NITRILE FDSRV PF BLU 304363283	2306775	56.45		112.90				
							GROUP TOTAL****	151.11			
MISC CHARGES							ALLOWANCE FOR DROP SIZE	13.34-			
							CHGS FOR FUEL SURCHARGE	6.00			
ORDER SUMMARY							: 2750597				

*Handwritten signature and initials*

*200-5500 = 1287.77  
200-7450 = 38.21  
Total = 1325.98*

CASES	SPLIT	TOT. PCS	CUBE	GROSS WT.	OPEN: 7:00 AM	CLOSE: 5:00 PM	REMIT TO	SUB TOTAL		
29		29	23.1	836			SYSCO JACKSONVILLE 1501 LEWIS INDUSTRIAL DR. JACKSONVILLE, FL 32254	1325.98		
45	4	49	39.5	1305				TAX TOTAL		
DRIVER'S SIGN							NO. PCS DELVD.	CUST. SIGNED INVOICE EVIDENCE OF ALL ITEMS SIGN <b>X</b>	NO. PCS REC.	INVOICE TOTAL
IMPORTANT FACT PROVISION: THE PERISHABLE AGRICULTURAL COMMODITIES LISTED ON THIS INVOICE ARE SUBJECT TO THE STATUTORY TRUST AUTHORIZED BY SECTION 5 (C) OF THE PERISHABLE AGRICULTURAL COMMODITIES ACT 1930 (U.S.C. 495(C)). THE SELLER OF THIS COMMODITY RECEIVES A TRUST CLAIM OVER THESE COMMODITIES, ALL INVENTORIES OF FOOD OR OTHER PRODUCTS DERIVED FROM THESE COMMODITIES AND ANY RECEIVABLES OR PROCEEDS FROM THE SALE OF THESE COMMODITIES UNTIL FULL PAYMENT IS RECEIVED. FURTHER, YOU AGREE WITH RESPECT TO ANY DISPUTE ARISING OUT OF YOUR RECEIPT OF THESE PRODUCTS/SERVICES: YOU ARE GIVING UP YOUR RIGHT TO SERVE IN ANY REPRESENTATIVE CAPACITY OR TO PARTICIPATE AS A MEMBER OF A CLASS OF CLAIMANTS, IN ANY LAWSUIT INVOLVING ANY SUCH DISPUTE.							PAYABLE ON OR BEFORE		TOTAL	
							2/03/25	1325.98	LAST PAGE	

EQUAL OPPORTUNITY AND AFFIRMATIVE ACTION CLAUSES OF 41 CFR 60-1.4, 60-250.4 AND 60-714.4 ARE INCORPORATED HEREIN BY REFERENCE





EAGLE LANDING SWIM TENNIS  
3975 EAGLE LANDING PKWY  
ORANGE PARK FL 32065



SYSCO JACKSONVILLE, INC.  
1501 LEWIS INDUSTRIAL DRIVE  
JACKSONVILLE, FL 32254  
1-800-797-2627 (1-800 SYSCO CS)

904-291-4343

EAGLE LANDING GOLF CLUB  
3989 EAGLE LANDING PKWY  
ORANGE PARK FL 32065 -2641

CUSTOMER'S ORIGINAL INVOICE CONFIDENTIAL PROPERTY OF SYSCO

DELV. DATE	CUSTOMER	INVOICE NUMBER	PAGE
1/04/25			
TRUCK STOP	496745	583034925	3 1
621/003			
ROUTE	PURCHASE ORDER		
6637	TERMS -PAST DUE BALANCES ARE SUBJECT TO SERVICE CHARGE		
	Net 30		
	MANIFEST# 1276541 NORMAL DELIVERY		
	MA: TVADC SCARLETT BAYLESS		

DRIVER:

DOC	QTY	PACK	SIZE	ITEM DESCRIPTION	ITEM CODE	UNIT PRICE	UNIT TAX AMOUNT	EXTENDED PRICE	INVOICE ADJUSTMENTS	
									CODE QTY	
				FOOD SAFETY REMINDER: NOTHING IS MORE IMPORTANT TO SYSCO THAN DELIVERING SAFE PRODUCTS. PLEASE VERIFY EACH ORDER UPON RECEIPT BECAUSE COOLER ITEMS CANNOT BE RETURNED LATER.						
				SALTWATER FISH LIC WD-4511	FRESHWATER FISH LIC FWD-303				SHELLFISH CERT NUMBER 182 SS	
				***DAIRY***						
F	1	CS	13GAL	BLU BNY ICE CREAM BIRTHDAY CA 10070640050502	7971849	41.35		41.35		
F	1	CS	13 GAL	TILAMOK ICE CREAM CHOCLTY CHP 00072830630665	3608694	34.07		34.07		
F	1	CS	13 GAL	WHLFCLS ICE CREAM STWBRY 1026398	9188624	24.03		24.03		
F	1	CS	13 GAL	WHLFIMP ICE CREAM VANILLA 1047606	1921089	30.73		30.73		
				GROUP TOTAL****				130.18		
				***CANNED & DRY***						
C	1S	ONLY36 CT		HERSHEY CANDY BAR CHOC MILK 3400024000	5488366	37.83		37.83		
C	1S	ONLY36 CT		HERSHEY CANDY BAR KIT KAT 1.5 OZ 3400024600	4599775	37.83		37.83		
C	1S	ONLY36 CT		MARS CANDY BAR 3 MUSKETEER 42208	1760531	37.83		37.83		
C	1S	ONLY36 CT		M&M CANDY M&M PLAIN 1.69 OZ 317489	4055945	50.45		50.45		
D	1	CS	160 CT	LAYS CHIP VARIETY FRITO LA 00028400318310	6586721	42.02		42.02		
D	1	CS	2420 OZ	GATRADE DRINK CHERRY GLACIER 10052000042143	7071108	29.84		29.84		
D	2	CS	2420 OZ	GATRADE DRINK FROST RIPTIDE R 10052000324881	8399529	29.84		59.68		
D	2	CS	2420 OZ	GATRADE DRINK FRUIT PUNCH G2 10052000204053	6508978	29.84		59.68		
D	2	CS	2420 OZ	GATRADE DRINK FRUIT PUNCH WID 10052000328667	7468515	29.84		59.68		
D	2	CS	2420 OZ	GATRADE DRINK LEMON LIME G ZE 10052000042129	9901694	29.84		59.68		
D	2	CS	2420 OZ	GATRADE DRINK LMN/LM WIDEMOUT 10052000328681	7468507	29.84		59.68		

CASES	SPLIT	TOT. PCS	CUBE	GROSS WT.	OPEN: 7:00 AM	CLOSE: 5:00 PM	REMIT TO
16	4	20	16.4	469			SYSCO JACKSONVILLE 1501 LEWIS INDUSTRIAL DR JACKSONVILLE, FL 32254
DRIVER'S SIGN							NO. PCS DELVD.
CUST. SIGNED INVOICE EVIDENCE OF ALL ITEMS							NO. PCS REC.
							TAX TOTAL
							INVOICE TOTAL
							TOTAL 664.38

IMPORTANT NOTICE: THE PERISHABLE AGRICULTURAL COMMODITIES LISTED ON THIS INVOICE ARE SUBJECT TO THE STATUTORY TRUST AUTHORIZED BY SECTION 5 (C) OF THE PERISHABLE AGRICULTURAL COMMODITIES ACT 1930 (U.S.C. 495(C)). THE SELLER OF THIS COMMODITY RETAINS A TRUST CLAIM OVER THESE COMMODITIES. ALL INVENTORIES OF FOOD OR OTHER PRODUCTS DERIVED FROM THESE COMMODITIES AND ANY RECEIVABLES OR PROCEEDS FROM THE SALE OF THESE COMMODITIES UNTIL FULL PAYMENT IS RECEIVED. FURTHER, YOU AGREE WITH RESPECT TO ANY DISPUTE ARISING OUT OF YOUR RECEIPT OF THESE PRODUCTS/SERVICES: YOU ARE GIVING UP YOUR RIGHT TO SERVE IN ANY REPRESENTATIVE CAPACITY, OR TO PARTICIPATE AS A MEMBER OF A CLASS OF CLAIMANTS, IN ANY LITIGATION INVOLVING ANY SUCH DISPUTE.

PAYABLE ON OR BEFORE

CONT. ON PAGE 2

EQUAL OPPORTUNITY AND AFFIRMATIVE ACTION CLAUSES OF 41 CFR 60-1.4, 60-250.4 AND 60-714.4 ARE INCORPORATED HEREIN BY REFERENCE



# ACCOUNT ACTIVITY STATEMENT

RETURN MAIL ADDRESS  
 PO BOX 790420  
 ST. LOUIS, MO 63179

**Commercial Account:** 6035 3225 3929 3211  
**Statement Date:** 01/13/25  
**Credit Line:** \$12,000  
**Credit Available:** \$8,115

SOUTH VILLAGE ODD  
 3989 EAGLE LANDING PKWY  
 ORANGE PARK, FL 32065-2641

<b>Account Balance</b>	<b>\$3,884.22</b>
------------------------	-------------------

## Account Information

Please see Payment Page(s) for Amount Due and Payment Due Date(s)

Current Payments and Unapplied Payments	-\$1,919.51
Current Purchases and Debits	\$1,756.61
Current Returns, Exchanges and Adjustments	\$0.00
Previously Billed Invoices	\$2,127.61

### PAST DUE INVOICES

1-29 Days	30-59 Days	60-89 Days	90-119 Days	120-149 Days	150-179 Days	180+ Days
\$0.00	\$0.00	\$0.00	\$0.00	\$0.00	\$0.00	\$0.00

201123

**PATH TO PRO NETWORK**

**POST JOBS. FIND LABOR. HIRE FASTER.**

Hire for Your Crew in the Path to Pro Network  
[homedepot.com/network](http://homedepot.com/network)

Any contact related to fraud on your The Home Depot Commercial Account should be handled urgently. Citi Retail Services will never call or text you asking for the card number (even partial), or security code on the back of your card. Confirm communications claiming to be from Citi Retail Services by terminating any suspect interactions and calling us at the number on the back of your card.

### CURRENT PAYMENTS AND UNAPPLIED PAYMENTS

Payments received since the last statement period.  
 Please contact us with your instructions on how to apply to specific invoices.

Date	Amount
01/06/25	-\$1,919.51
<b>Total</b>	<b>-\$1,919.51</b>

### CURRENT PURCHASES AND DEBITS

Date	Purchase Location/Description	Invoice #	Purchase Order/Job Name	Customer Agreement #	Amount	Due Date
12/13/24	THE HOME DEPOT JACKSONVILLE, FL	9013565	TENNIS		\$132.91	02/28/25
12/13/24	THE HOME DEPOT JACKSONVILLE, FL	9013614	TENNIS		\$249.35	02/28/25
12/17/24	THE HOME DEPOT JACKSONVILLE, FL	5013989	GOLF		\$50.19	02/28/25
12/20/24	THE HOME DEPOT MIDDLEBURG, FL	2015828	GOLF		\$138.57	02/28/25
12/26/24	THE HOME DEPOT JACKSONVILLE, FL	6014557	GOLF		\$42.98	02/28/25
12/30/24	THE HOME DEPOT MIDDLEBURG, FL	2010477	GOLF		\$250.14	02/28/25

<b>Questions About Your Account</b> ACCT MGR DANIEL TOSCANO EXT 5222876 PHONE 1-800-494-1946 (TTY: 711) FAX 1-877-969-6282 EMAIL DANIEL.TOSCANO@CITI.COM	Send Billing Inquiries to: HOME DEPOT CREDIT SERVICES PO Box 790340 St. Louis, MO 63179-0340	Send a SECURE MESSAGE right now to a customer service professional online at <a href="http://myhomedepotaccount.com">myhomedepotaccount.com</a>
--	---	---



**Other Account and Payment Information**

**WHEN YOUR PAYMENT WILL BE CREDITED:** For payments by regular mail, please allow 5-7 days for your payment to reach us. Payment must be received in proper form at our processing facility by 5 p.m. local time there to be credited as of that day. All payments received at the processing facility in proper form after that hour will be credited as of the following day. There may be a delay of up to 5 days in crediting a payment sent by mail if it is not in the proper form or is addressed to a location other than the address listed on the return envelope or on the front of the payment coupon, or, for courier or express mail payments, to the Express Mail address set forth in the Express Mail section.

**PROPER FORM** for payments sent by mail or courier.

**For a payment to be in proper form, you should:**

- **ENCLOSE** your check or money order. No cash, gift cards, or foreign currency please.
- **INCLUDE** the last four digits of your account number and name.

**COPY FEE.** We charge \$5 for each copy of a billing statement that dates back 3 months or more. We add the fee to a balance of our choosing. We reserve the right to add this fee to balances subject to a higher annual percentage rate. We waive the fee if your request for the copy relates to a billing error or disputed purchase.

**PAYMENT OTHER THAN BY MAIL:**

- **Online Payments.** Go to the URL on Page 1 of your statement to make a payment. For security reasons, you may not be able to pay your entire New Balance the first time you make a payment online. The payment cutoff time for Online Bill Payments is 5 p.m. Eastern time. Payments received after 5 p.m. Eastern time will be credited as of the next day.

- **Phone.** Call the phone number on Page 1 of your statement to make a payment. We may process your payment electronically after we verify your identity. There is no fee for this service. The payment cutoff time for Phone Payments is 5 p.m. Eastern time. Payments received after 5 p.m. Eastern time will be credited as of the next day.

- **Express Payments.** Send payment by courier or express mail to: Attn: Prox Payment Dept, 6716 Grade Lane, Building 9, Suite 910, Louisville, KY, 40213. Payment must be received in proper form, at the proper address, by 5 p.m. Eastern time in order to be credited as of that day. All payments received in proper form, at the proper address, after 5 p.m. Eastern time will be credited as of the next day.

- **In-Store Payments.** For your added convenience, payments can be made at The Home Depot® stores, with no service fee. Any payment in proper form accepted in-store will be credited as of that day. However, credit availability may be subject to verification of funds.

**If you send an eligible check with this payment coupon you authorize us to complete your payment by electronic debit. If we do the checking account will be debited in the amount on the check. We may do this as soon as the day we receive the check. Also the check will be destroyed.**

**REPORT A LOST, STOLEN OR NEVER RECEIVED CARD**

**IMMEDIATELY:** Customer Service is available 24 hours a day, 7 days a week.

**CUSTOMER SERVICE WRITTEN INQUIRY ADDRESS:**

Home Depot Credit Services, P.O. Box 790340, St. Louis, MO 63179



**CURRENT PURCHASES AND DEBITS, cont.**

Date	Purchase Location/Description	Invoice #	Purchase Order/Job Name	Customer Agreement #	Amount	Due Date
12/31/24	THE HOME DEPOT JACKSONVILLE, FL	1014968	TENNIS		\$78.06	03/31/25
01/07/25	THE HOME DEPOT MIDDLEBURG, FL	4011204	GOLF		\$224.09	03/31/25
01/09/25	THE HOME DEPOT JACKSONVILLE, FL	2010606	DOLPHK		\$82.11	03/31/25
01/09/25	THE HOME DEPOT JACKSONVILLE, FL	2010607	DOLPHK		\$12.94	03/31/25
01/09/25	THE HOME DEPOT JACKSONVILLE, FL	2010643	GOLFM		\$270.05	03/31/25
01/10/25	THE HOME DEPOT MIDDLEBURG, FL	1011544	TENNIS		\$225.22	03/31/25
<b>TOTAL</b>					<b>\$1,756.61</b>	

**PREVIOUSLY BILLED INVOICES**

Please submit payment for all past due amounts.

Date	Purchase Location/Description	Invoice #	Purchase Order/Job Name	Customer Agreement #	Amount	Due Date
11/18/24	THE HOME DEPOT MIDDLEBURG, FL	4022049	TENNIS		\$309.00	01/31/25
11/19/24	THE HOME DEPOT JACKSONVILLE, FL	3011865	TANSTONE		\$184.40	01/31/25
11/19/24	THE HOME DEPOT MIDDLEBURG, FL	3012490	GOLF		\$227.09	01/31/25
11/20/24	THE HOME DEPOT MIDDLEBURG, FL	2012586	POOL		\$108.37	01/31/25
11/20/24	THE HOME DEPOT MIDDLEBURG, FL	2112552	Return:		-\$86.33	01/31/25
11/26/24	THE HOME DEPOT JACKSONVILLE, FL	6012265	TENECE		\$287.85	01/31/25
12/03/24	THE HOME DEPOT MIDDLEBURG, FL	9013952	GYM		\$341.59	02/28/25
12/04/24	THE HOME DEPOT MIDDLEBURG, FL	8014079	GOLF		\$271.33	02/28/25
12/06/24	THE HOME DEPOT MIDDLEBURG, FL	6014288	GOLF		\$343.48	02/28/25
12/06/24	THE HOME DEPOT MIDDLEBURG, FL	6014289	GOLF		\$67.86	02/28/25
12/10/24	THE HOME DEPOT JACKSONVILLE, FL	2013358	GYM		\$72.97	02/28/25
<b>TOTAL</b>					<b>\$2,127.61</b>	

**PURCHASE HISTORY**

Year to Date	\$892.47
Life to Date	\$107,835.28

321103

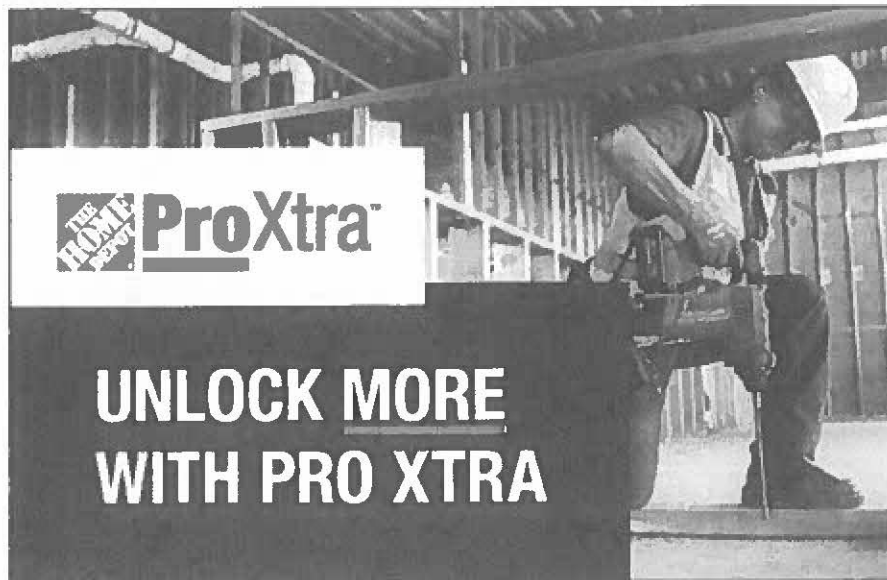

**THE HOME DEPOT ProXtra**

**UNLOCK MORE WITH PRO XTRA**

**Make the Most of Your Membership**

**Scan your app every time you check out to track your spend and earn toward Perks.**

312



# DOORS FOR EVERY STYLE: YOUR PROJECT STARTS HERE

- Get interior and exterior doors, hardware and more all in one supply drop
- Find the quantities you need for any size job
- Available for job-site delivery as soon as next day



Shop the  
Whole Job



314

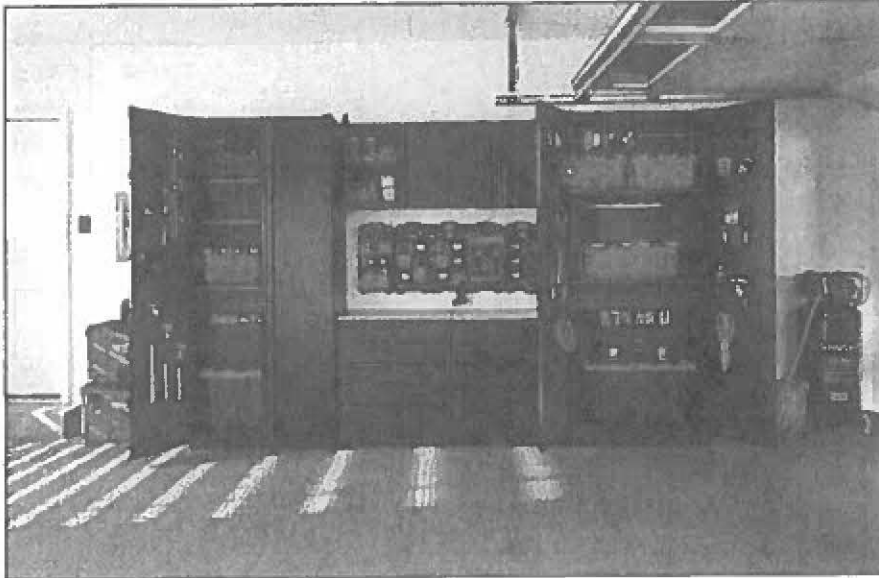

## SAVE ON SELECT STORAGE AND ORGANIZATION



318

53931026.1 01774309 9-2

EDUR2E

EDUR402A 5019 36 20250114 PG 3 OF 9

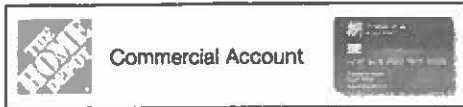

Remit payment and make checks payable to:  
 HOME DEPOT CREDIT SERVICES  
 DEPT. 32 - 2539293211  
 PO BOX 9001043  
 LOUISVILLE, KY 40290-1043

# PAYMENT PAGE

Commercial Account 6035 3225 3929 3211  
 Statement Date 01/13/25  
 View, manage and pay your account online at  
 myhomedepotaccount.com

**Invoices to Be Paid**      **IMPORTANT:**

To ensure accurate posting of your payment, please indicate which invoices you are paying by checking the appropriate box below. To apply a credit to an invoice, write in the invoice number of the debit transaction that you would like to have applied to, in the "Invoice Number" column next to the credit. Please remit entire Payment Page(s) when sending payment.

### CREDITS

Transaction Date	Invoice #	Original Invoice Amount	Credit Amount	Apply to Invoice #	Invoice Number (Enter invoice number in which to apply credit)
11/20/24	2112552	-\$86.33	-\$86.33		

### CURRENT ACTIVITY

Transaction Date	Invoice #	Original Invoice Amount	Amount Due	Payment Due Date	Check If Paying	Payment Amount (if less than Amount Due)
12/13/24	9013565	\$132.91	\$132.91	02/28/25	<input type="checkbox"/>	\$
12/13/24	9013614	\$249.35	\$249.35	02/28/25	<input type="checkbox"/>	\$
12/17/24	5013989	\$50.19	\$50.19	02/28/25	<input type="checkbox"/>	\$
12/20/24	2015828	\$138.57	\$138.57	02/28/25	<input type="checkbox"/>	\$
12/26/24	6014557	\$42.98	\$42.98	02/28/25	<input type="checkbox"/>	\$
12/30/24	2010477	\$250.14	\$250.14	02/28/25	<input type="checkbox"/>	\$
12/31/24	1014968	\$78.06	\$78.06	03/31/25	<input type="checkbox"/>	\$
01/07/25	4011204	\$224.09	\$224.09	03/31/25	<input type="checkbox"/>	\$
01/09/25	2010806	\$82.11	\$82.11	03/31/25	<input type="checkbox"/>	\$
01/09/25	2010607	\$12.94	\$12.94	03/31/25	<input type="checkbox"/>	\$
01/09/25	2010843	\$270.05	\$270.05	03/31/25	<input type="checkbox"/>	\$
01/10/25	1011544	\$225.22	\$225.22	03/31/25	<input type="checkbox"/>	\$

### PREVIOUSLY BILLED OPEN ITEMS

Transaction Date	Invoice #	Original Invoice Amount	Amount Due	Payment Due Date	Check if Paying	Payment Amount (if less than Amount Due)
11/18/24	4022049	\$309.00	\$309.00	01/31/25	<input type="checkbox"/>	\$
11/19/24	3011665	\$184.40	\$184.40	01/31/25	<input type="checkbox"/>	\$

continued on next page



P.O. Box 790420  
 St. Louis, MO 63179

Your Account Number is 6035 3225 3929 3211



Statement Date 01/13/25  
 Account Balance \$3,884.22  
 Check here if paying all invoices

For proper credit, please write  
 6035 3225 3929 3211  
 on your check and enclose  
 with this payment coupon.

Statement Enclosed

Amount Enclosed: \$

Please see reverse side to change your address.  
 Make Checks Payable to ▼

SOUTH VILLAGE CDD  
 3989 EAGLE LANDING PKWY  
 ORANGE PARK, FL 32065-2641

HOME DEPOT CREDIT SERVICES  
 DEPT. 32 - 2539293211  
 PO BOX 9001043  
 LOUISVILLE, KY 40290-1043



**PREVIOUSLY BILLED OPEN ITEMS, cont.**

Transaction Date	Invoice #	Original Invoice Amount	Amount Due	Payment Due Date	Check If Paying	Payment Amount (If less than Amount Due)
11/19/24	3012490	\$227.09	\$227.09	01/31/25	<input type="checkbox"/>	\$
11/20/24	2012588	\$108.37	\$108.37	01/31/25	<input type="checkbox"/>	\$
11/26/24	6012265	\$287.85	\$287.85	01/31/25	<input type="checkbox"/>	\$
12/03/24	9013952	\$341.59	\$341.59	02/28/25	<input type="checkbox"/>	\$
12/04/24	8014079	\$271.33	\$271.33	02/28/25	<input type="checkbox"/>	\$
12/06/24	6014288	\$343.48	\$343.48	02/28/25	<input type="checkbox"/>	\$
12/06/24	6014289	\$67.86	\$67.86	02/28/25	<input type="checkbox"/>	\$
12/10/24	2013358	\$72.97	\$72.97	02/28/25	<input type="checkbox"/>	\$

55951826.1 01774389 0-2

hottze

EOLR402A 5819 36 20250114 PG 4 OF 9

**Easily manage your contact information**

It's important we have your current contact information, so if anything changes (including your email or mailing address or phone number), please do one of the following to easily update your information:

- You can update your contact information by logging into your online account via the URL located in the **Questions About Your Account** section on the front of your statement, or
- Call the phone number located in the **Questions About Your Account** section on the front of your statement

**Shop Quality Paint & Supplies from the Brands Pros Trust**



Sign up for the Pro Xtra Paint Rewards program at [homedepot.com/propaint](http://homedepot.com/propaint)





Commercial Account



Remit payment and make checks payable to: HOME DEPOT CREDIT SERVICES DEPT. 32 - 2539293211 PO BOX 9001043 LOUISVILLE, KY 40290-1043

# INVOICE DETAIL

BILL TO:  
Acct: 6035 3225 3929 3211  
SOUTH VILLAGE CDD

Amount Due:	Trans Date:	DUE DATE:	Invoice #:
\$132.91	12/13/24	02/28/25	9013565
PO: TENNIS		Store: 6890, JACKSONVILLE, FL	

PRODUCT	SKU #	QUANTITY	UNIT PRICE	TOTAL PRICE
12.2G SWING TOP TRASH CAN, BLACK	10082928370000400002	1.0000 EA	\$20.97	\$20.97
HOOVER UPRIGHT WINDTUNNEL BAGLESS	10066854250001600002	1.0000 EA	\$139.00	\$139.00
BERNZOMATIC PROPANE FUEL 16.4OZ 2PK	00008113040001500011	1.0000 EA	\$10.98	\$10.98
DISCOUNT	00000000000000000005	1.0000 EA	-\$60.00	-\$60.00
BERNZOMATIC PROPANE FUEL 16.4OZ 2PK	00008113040001500011	1.0000 EA	\$10.98	\$10.98
BERNZOMATIC PROPANE FUEL 16.4OZ 2PK	00008113040001500011	1.0000 EA	\$10.98	\$10.98

Purchased by: SWENSON SCOTT  
Customer #: 00002

SUBTOTAL	\$132.91
TAX	\$0.00
TOTAL	\$132.91

*600-7450  
8  
1/28/25*

BILL TO:  
Acct: 6035 3225 3929 3211  
SOUTH VILLAGE CDD

Amount Due:	Trans Date:	DUE DATE:	Invoice #:
\$249.35	12/13/24	02/28/25	9013614
PO: TENNIS		Store: 6890, JACKSONVILLE, FL	

PRODUCT	SKU #	QUANTITY	UNIT PRICE	TOTAL PRICE
SWIFFER HD DRY 32 CT PET	10078630680000400011	1.0000 EA	\$14.97	\$14.97
LOCTITE POWER GRAB ULT CLEAR 9 OZ	10040889200000100010	1.0000 EA	\$12.98	\$12.98
EASYWRING RINSECLEAN DEEP CLEAN BIN	10110532300000400016	1.0000 EA	\$18.97	\$18.97
MCEOR6	10041446230000400020	1.0000 EA	\$5.67	\$5.67
HDX MICROFIBER DUSTER	00004624580000400021	1.0000 EA	\$5.97	\$5.97
ANVIL 10 IN TOOL BAG 3 PACK	10114651870001100014	1.0000 EA	\$12.98	\$12.98
UNGER COB WEB & CORNER DUSTER	10065950000000400005	1.0000 EA	\$10.97	\$10.97
AMERIGAS PROPANE EXCHANGE	00006003720002200004	7.0000 EA	\$21.98	\$153.86
ANVIL 10 IN TOOL BAG 3 PACK	10114651870001100014	1.0000 EA	\$12.98	\$12.98

Purchased by: SWENSON SCOTT  
Customer #: 00002

SUBTOTAL	\$249.35
TAX	\$0.00
TOTAL	\$249.35

*600-7245  
8  
1/28/25*

BILL TO:  
Acct: 6035 3225 3929 3211  
SOUTH VILLAGE CDD

Amount Due:	Trans Date:	DUE DATE:	Invoice #:
\$50.19	12/17/24	02/28/25	5013989
PO: GOLF		Store: 6890, JACKSONVILLE, FL	

PRODUCT	SKU #	QUANTITY	UNIT PRICE	TOTAL PRICE
SOFTSOAP ANTIBAC HS CRISPCLN 11.25OZ	10023033980000400004	1.0000 EA	\$2.87	\$2.87
SOFTSOAP HS REFILL CLEAN 50OZ	10046524180000400004	1.0000 EA	\$6.48	\$6.48
SOFTSOAP HS REFILL CLEAN 50OZ	10046524180000400004	1.0000 EA	\$6.48	\$6.48
KEY CAPS	00001684570000500003	1.0000 EA	\$2.97	\$2.97
SOFTSOAP ANTIBAC HS CRISPCLN 11.25OZ	10023033980000400004	1.0000 EA	\$2.87	\$2.87
CARABINEER WITH STRAP	00005527440000500003	1.0000 EA	\$2.97	\$2.97
MINUTE KEY LICENSE KEY	10040594510000500003	1.0000 EA	\$5.67	\$5.67
MKBRASSKEY	10040594560000500003	1.0000 EA	\$4.97	\$4.97
MKBRASSKEY	10040594560000500003	1.0000 EA	\$4.97	\$4.97
MKBRASSKEY	10040594560000500003	1.0000 EA	\$4.97	\$4.97

continued →

321105



This page intentionally left blank.

53931826.1 01774309 0-2

SOTTE

EOLR402A 5019 36 20250114 PG 5 OF 9



Commercial Account



Remit payment and make checks payable to: HOME DEPOT CREDIT SERVICES DEPT. 32 - 2539293211 PO BOX 6001043 LOUISVILLE, KY 40290-1043

# INVOICE DETAIL

1470-000 -50.19  
1460-000 50.19

Invoice #: **5013989**  
continued

PRODUCT	SKU #	QUANTITY	UNIT PRICE	TOTAL PRICE
MKBRASSKEY	10040594560000500003	1.0000 EA	\$4.97	\$4.97

Purchased by: SWENSON SCOTT  
Customer #: 00002

<b>SUBTOTAL</b>	\$50.19
<b>TAX</b>	\$0.00
<b>TOTAL</b>	\$50.19

*240-7440  
5  
1/29/25*

BILL TO:  
Acct: 6035 3225 3929 3211  
SOUTH VILLAGE CDD

Amount Due:	Trans Date:	DUE DATE:	Invoice #:
\$138.57	12/20/24	02/28/25	<b>2015828</b>
PO: GOLF		Store: 6935, MIDDLEBURG, FL	

PRODUCT	SKU #	QUANTITY	UNIT PRICE	TOTAL PRICE
ROUNDUP W&GK4 CONC 64 OZ	10099641010000100004	1.0000 EA	\$44.97	\$44.97
LOCTITE ULTRA GEL SUPER GLUE .14 OZ	00006886260000400013	1.0000 EA	\$5.68	\$5.68
AMERIGAS PROPANE EXCHANGE	00006003720002200004	4.0000 EA	\$21.98	\$87.92

Purchased by: SWENSON SCOTT  
Customer #: 00002

<b>SUBTOTAL</b>	\$138.57
<b>TAX</b>	\$0.00
<b>TOTAL</b>	\$138.57

*800-7244  
6  
1/14/25*

BILL TO:  
Acct: 6035 3225 3929 3211  
SOUTH VILLAGE CDD

1470-000 -42.98  
1460-000 42.98

Amount Due:	Trans Date:	DUE DATE:	Invoice #:
\$42.98	12/26/24	02/28/25	<b>6014557</b>
PO: GOLF		Store: 6890, JACKSONVILLE, FL	

PRODUCT	SKU #	QUANTITY	UNIT PRICE	TOTAL PRICE
BERNZOMATIC FLAME COMMANDER TORCH KI	10118584340001500012	1.0000 EA	\$42.98	\$42.98

Purchased by: SWENSON SCOTT  
Customer #: 00002

<b>SUBTOTAL</b>	\$42.98
<b>TAX</b>	\$0.00
<b>TOTAL</b>	\$42.98

*410-7440  
5  
1/14/25*

BILL TO:  
Acct: 6035 3225 3929 3211  
SOUTH VILLAGE CDD

Amount Due:	Trans Date:	DUE DATE:	Invoice #:
\$250.14	12/30/24	02/28/25	<b>2010477</b>
PO: GOLF		Store: 6935, MIDDLEBURG, FL	

PRODUCT	SKU #	QUANTITY	UNIT PRICE	TOTAL PRICE
AMERIGAS PROPANE EXCHANGE	00006003720002200004	11.0000 EA	\$22.74	\$250.14

Purchased by: SWENSON SCOTT  
Customer #: 00002

<b>SUBTOTAL</b>	\$250.14
<b>TAX</b>	\$0.00
<b>TOTAL</b>	\$250.14

*800-7244  
6  
1/14/25*

BILL TO:  
Acct: 6035 3225 3929 3211  
SOUTH VILLAGE CDD

Amount Due:	Trans Date:	DUE DATE:	Invoice #:
\$78.06	12/31/24	03/31/25	<b>1014968</b>
PO: TENNIS		Store: 6890, JACKSONVILLE, FL	

PRODUCT	SKU #	QUANTITY	UNIT PRICE	TOTAL PRICE
HDX 27 GALLON TOUGH TOTE	00002075850001600002	1.0000 EA	\$9.98	\$9.98

continued →

90773E  
321106



This page intentionally left blank.

5893826.1 0174384 0-2

90112E

EPURADA 5019 86 20250114 40 1 DF 9





Commercial Account



Remit payment and make checks payable to:  
HOME DEPOT CREDIT SERVICES  
DEPT. 32 - 2539293211  
PO BOX 9001043  
LOUISVILLE, KY 40290-1043

# INVOICE DETAIL

Invoice #:  
**1014968**  
continued

PRODUCT	SKU #	QUANTITY	UNIT PRICE	TOTAL PRICE
HDX 27 GALLON TOUGH TOTE	00002075850001600002	1.0000 EA	\$9.98	\$9.98
WD-40 SPECIALIST SPRAY&STAY	10016209700003100016	1.0000 EA	\$12.18	\$12.18
GEL 100Z				
HDX 27 GALLON TOUGH TOTE	00002075850001600002	1.0000 EA	\$9.98	\$9.98
TOOLBOX WHITE RAGS 200CT BOX	10015466270001000005	1.0000 EA	\$12.98	\$12.98
HDX 27 GALLON TOUGH TOTE	00002075850001600002	1.0000 EA	\$9.98	\$9.98
TOOLBOX WHITE RAGS 200CT BOX	10015466270001000005	1.0000 EA	\$12.98	\$12.98

Purchased by: SWENSON SCOTT  
Customer #: 00002

<b>SUBTOTAL</b>	\$78.06
<b>TAX</b>	\$0.00
<b>TOTAL</b>	\$78.06

*607281  
APR 12/25*

BILL TO: 1470-000 -224.09  
Acct: 6035 3225 3929 3211 1460-000 224.09  
SOUTH VILLAGE CDD

Amount Due:	Trans Date:	DUE DATE:	Invoice #:
\$224.09	01/07/25	03/31/25	4011204
PO: GOLF		Store: 6935, MIDDLEBURG, FL	

PRODUCT	SKU #	QUANTITY	UNIT PRICE	TOTAL PRICE
MILK CRATE	10000318840001600002	1.0000 EA	\$11.98	\$11.98
MILK CRATE	10000318840001600002	1.0000 EA	\$11.98	\$11.98
MILK CRATE	10000318840001600002	1.0000 EA	\$11.98	\$11.98
ANVIL D-HANDLE TRANSFER SHOVEL	00002278380001100003	1.0000 EA	\$19.98	\$19.98
HDX 13G DRAWSTRING KITCHEN 150CT	00007168660000400003	1.0000 EA	\$19.97	\$19.97
HDX 13G DRAWSTRING KITCHEN 150CT	00007168660000400003	1.0000 EA	\$19.97	\$19.97
HDX PAINTER'S TERRY TOWEL - 75PK	10056459150001000005	1.0000 EA	\$29.98	\$29.98
AIM N FLAME UTILITY LIGHTER (3 PACK)	10103614530002200006	1.0000 EA	\$12.98	\$12.98
2 GAL. SPRAY	10057865880000100008	1.0000 EA	\$39.97	\$39.97
2'X4' EGG CRATE WHT LOUVER	00001166020000500006	1.0000 EA	\$19.44	\$19.44
DISCOUNT	00000000000000000005	1.0000 EA	-\$3.00	-\$3.00
LIBMAN ALL PURPOSE HOUSEHOLD BRUSH	00005712370000400020	1.0000 EA	\$5.98	\$5.98
BRUSHES	10000186300000400005	1.0000 EA	\$7.97	\$7.97
BRUSHES	10000186300000400005	1.0000 EA	\$7.97	\$7.97
CARBINR W/OPNR-NCAA-U OF GA	00002067390000500003	1.0000 EA	\$6.47	\$6.47
BULLDOGS				
CARBINR W/OPNR-NCAA-UNIV OF FL	00002084650000500003	1.0000 EA	\$6.47	\$6.47
GATOR				
DISCOUNT	00000000000000000005	1.0000 EA	-\$1.00	-\$1.00
DISCOUNT	00000000000000000005	1.0000 EA	-\$1.00	-\$1.00
DISCOUNT	00000000000000000005	1.0000 EA	-\$1.00	-\$1.00
DISCOUNT	00000000000000000005	1.0000 EA	-\$3.00	-\$3.00

Purchased by: SWENSON SCOTT  
Customer #: 00002

<b>SUBTOTAL</b>	\$224.09
<b>TAX</b>	\$0.00
<b>TOTAL</b>	\$224.09

*50-7248  
APR 12/25*

BILL TO:  
Acct: 6035 3225 3929 3211  
SOUTH VILLAGE CDD

Amount Due:	Trans Date:	DUE DATE:	Invoice #:
\$82.11	01/09/25	03/31/25	2010606
PO: DOLPHK		Store: 6890, JACKSONVILLE, FL	

PRODUCT	SKU #	QUANTITY	UNIT PRICE	TOTAL PRICE
FEIT 200W A21 SW DM CLEAR INCAN	10052851830000100040	1.0000 EA	\$4.47	\$4.47

continued →

321307



This page intentionally left blank.

EDUC024 5019 38 20250116 PG 7 OF 9

53931824.1 01774389 0-2

NOTICE



Commercial Account



Remit payment and make checks payable to: HOME DEPOT CREDIT SERVICES DEPT. 32 - 2539293211 PO BOX 9001043 LOUISVILLE, KY 40290-1043

# INVOICE DETAIL

1470-000 -82.11  
1460-000 82.11

Invoice #:  
**2010606**  
continued

PRODUCT	SKU #	QUANTITY	UNIT PRICE	TOTAL PRICE
FEIT 250W BR40 HEAT LAMP ICAN RED	10052851890000100039	1.0000 EA	\$10.97	\$10.97
4 OUTLETS / 6 USB SPIN POWER - THE U	10052326290000300006	1.0000 EA	\$35.25	\$35.25
FEIT 200W A21 SW DM CLEAR INCAN	10052851830000100040	1.0000 EA	\$4.47	\$4.47
MINUTE KEY PAINTED KEY	10040594480000500003	1.0000 EA	\$5.67	\$5.67
MKBRASSKEY	10040594560000500003	1.0000 EA	\$4.97	\$4.97
MINUTE KEY PAINTED KEY	10040594480000500003	1.0000 EA	\$5.67	\$5.67
MINUTE KEY PAINTED KEY	10040594480000500003	1.0000 EA	\$5.67	\$5.67
MKBRASSKEY	10040594560000500003	1.0000 EA	\$4.97	\$4.97

Purchased by: SWENSON SCOTT  
Customer #: 00002

<b>SUBTOTAL</b>	\$82.11
<b>TAX</b>	\$0.00
<b>TOTAL</b>	\$82.11

*400-7610  
APL  
1/29/25*

901126

BILL TO:  
Acct: 6035 3225 3929 3211  
SOUTH VILLAGE CDD

1470-000 -12.94  
1460-000 12.94

Amount Due:	Trans Date:	DUE DATE:	Invoice #:
\$12.94	01/09/25	03/31/25	<b>2010607</b>
PO: DOLPHK		Store: 6890, JACKSONVILLE, FL	

PRODUCT	SKU #	QUANTITY	UNIT PRICE	TOTAL PRICE
CARBINR W/OPNR-NCAA-FL ST SEMINOLES	00002137420000500003	1.0000 EA	\$6.47	\$6.47
CARBINR W/OPNR-NCAA-FL ST SEMINOLES	00002137420000500003	1.0000 EA	\$6.47	\$6.47

Purchased by: SWENSON SCOTT  
Customer #: 00002

<b>SUBTOTAL</b>	\$12.94
<b>TAX</b>	\$0.00
<b>TOTAL</b>	\$12.94

*200-7444  
APL  
1/29/25*

BILL TO:  
Acct: 6035 3225 3929 3211  
SOUTH VILLAGE CDD

Amount Due:	Trans Date:	DUE DATE:	Invoice #:
\$270.05	01/09/25	03/31/25	<b>2010643</b>
PO: GOLFM		Store: 6890, JACKSONVILLE, FL	

PRODUCT	SKU #	QUANTITY	UNIT PRICE	TOTAL PRICE
ANVIL 14 T WELDED BOW RAKE	00006899630001100002	1.0000 EA	\$13.98	\$13.98
ANVIL 14 T WELDED BOW RAKE	00006899630001100002	1.0000 EA	\$13.98	\$13.98
DEWALT A FGL D-HNDL DIGGING SHOVS	10067093780001100003	1.0000 EA	\$37.98	\$37.98
CORONA MULTI-LINK LOPPER	10082556510001100015	1.0000 EA	\$39.98	\$39.98
CRESCENT 8 1/2 IN. ALL-PURPOSE SHEAR	10054458600000100006	1.0000 EA	\$8.97	\$8.97
PURAFILTER AC DRAIN CLEANER 8OZ	10084501320000200033	1.0000 EA	\$8.53	\$8.53
PURAFILTER AC DRAIN CLEANER 8OZ	10084501320000200033	1.0000 EA	\$8.53	\$8.53
ANVIL 14 T WELDED BOW RAKE	00006899630001100002	1.0000 EA	\$13.98	\$13.98
PURAFILTER AC DRAIN CLEANER 8OZ	10084501320000200033	1.0000 EA	\$8.53	\$8.53
DISCOUNT	00000000000000000005	1.0000 EA	-\$2.00	-\$2.00
GE CARBON WH HM SEDIMENT FLTR 2PK	00002014260000900007	1.0000 PK	\$11.96	\$11.96
HUSKY COMPACT FOLD LOCKBACK UTL KNIF	10103149680000100006	1.0000 EA	\$6.97	\$6.97
GE CARBON WH HM SEDIMENT FLTR 2PK	00002014260000900007	1.0000 PK	\$11.96	\$11.96
ROUNDUP W&GK4 CONC 32 OZ	10099641000000100004	1.0000 EA	\$24.97	\$24.97
32OZ RAIN-R-SHINE PVC CEMENT	00002569050000100021	1.0000 EA	\$19.38	\$19.38

continued →



This page intentionally left blank.

53731024.1 01774361 0-2

80772E

EOLR4324 5419 56 20250116 PG 8 OF 9



Commercial Account



Remit payment and make checks payable to:  
HOME DEPOT CREDIT SERVICES  
DEPT. 32 - 2539283211  
PO BOX 9001043  
LOUISVILLE, KY 40290-1043

# INVOICE DETAIL

1470-000 -270.05  
1460-000 270.05

Invoice #:  
**2010643**  
continued

PRODUCT	SKU #	QUANTITY	UNIT PRICE	TOTAL PRICE
32OZ RAIN-R-SHINE PVC CEMENT	00002569050000100021	1.0000 EA	\$19.38	\$19.38
MKE 6PC SCREWDRIVER SET	10000180950000100007	1.0000 EA	\$22.97	\$22.97

Purchased by: SWENSON SCOTT  
Customer #: 00002

<b>SUBTOTAL</b>	\$270.05
<b>TAX</b>	\$0.00
<b>TOTAL</b>	\$270.05

*440-7440  
APR 11 2015*

BILL TO:  
Acct: 6035 3225 3929 3211  
SOUTH VILLAGE CDD

<b>Amount Due:</b>	<b>Trans Date:</b>	<b>DUE DATE:</b>	<b>Invoice #:</b>
\$225.22	01/10/25	03/31/25	1011544
<b>PO: TENNIS</b>		<b>Store: 6935, MIDDLEBURG, FL</b>	

PRODUCT	SKU #	QUANTITY	UNIT PRICE	TOTAL PRICE
DYNAFLEX ULTRA 10.1 OZ GRAY ADVANCED	10035453270000200002	1.0000 EA	\$8.78	\$8.78
1X8X8 NO.2	00009148350000500002	1.0000 EA	\$17.43	\$17.43
1X8X8 NO.2	00009148350000500002	1.0000 EA	\$17.43	\$17.43
2X10X8 #2 PT	10017868630002000002	1.0000 EA	\$11.08	\$11.08
2X10X8 #2 PT	10017868630002000002	1.0000 EA	\$11.08	\$11.08
2X10X8 #2 PT	10017868630002000002	1.0000 EA	\$11.08	\$11.08
2X4-12FT #2PRIME PT GC WEATHERSHIELD	10017538270002000002	1.0000 EA	\$8.18	\$8.18
DYNAFLEX ULTRA 10.1 OZ GRAY ADVANCED	10035453270000200002	1.0000 EA	\$8.78	\$8.78
2X4-12FT #2PRIME PT GC WEATHERSHIELD	10017538270002000002	1.0000 EA	\$8.18	\$8.18
DISCOUNT	00000000000000000005	1.0000 EA	-\$32.06	-\$32.06
2X4-12FT #2PRIME PT GC WEATHERSHIELD	10017538270002000002	1.0000 EA	\$8.18	\$8.18
2X4-12FT #2PRIME PT GC WEATHERSHIELD	10017538270002000002	1.0000 EA	\$8.18	\$8.18
2X4-12FT #2PRIME PT GC WEATHERSHIELD	10017538270002000002	1.0000 EA	\$8.18	\$8.18
2X4-12FT #2PRIME PT GC WEATHERSHIELD	10017538270002000002	1.0000 EA	\$8.18	\$8.18
2X10-16FT #2	10017868840002000002	1.0000 EA	\$25.58	\$25.58
2X10-16FT #2	10017868840002000002	1.0000 EA	\$25.58	\$25.58
2X10-16FT #2	10017868840002000002	1.0000 EA	\$25.58	\$25.58
11/32 4X8 RTD PLYWOOD	00001660850000100002	2.0000 EA	\$22.90	\$45.80

Purchased by: SWENSON SCOTT  
Customer #: 00002

<b>SUBTOTAL</b>	\$225.22
<b>TAX</b>	\$0.00
<b>TOTAL</b>	\$225.22

*640-7440  
APR 11 2015*

60112E



This page intentionally left blank.

509181254.1 01774389 0-2

60112E

80664024 5519 34 29250114 PD 9 OF 9

9I - South Village CDD dba Eagle Landing      Pg 1  
A/P R - ACCOUNTS PAYABLE REC  
Check Register for Jan 1/25 thru Jan 31/25  
Manual/QUIK Checks

Check	Issued to:	Date	Check Amount
888364	COMCAST-CHARLOTTE	Jan 2/25	696.24
888368	COMCAST-CHARLOTTE	Jan 15/25	375.67
888371	CHAMPION BRANDS INC (ACH ONLY)	Jan 21/25	183.50
888372	CHAMPION BRANDS INC (ACH ONLY)	Jan 21/25	49.45
888373	SOUTHERN GLAZER S OF FL (ACH ONLY)	Jan 21/25	447.13
888374	CLAY CO UTILITY AUTHORITY	Jan 29/25	1,006.01
888375	NORTH FLORIDA SALES (ACH)	Jan 28/25	47.14
Total Manual/QUIK Checks Issued			2,805.14

===== End of Report =====



Account Number  
8495 74 144 1687294

Billing Date  
Dec 11, 2024

Services From  
Dec 15, 2024 to Jan 14, 2025

Page  
1 of 6

# Hello Eastwest Communities,

Thanks for choosing Comcast Business.

## Your bill at a glance

For 3979 EAGLE LANDING PKWY, BOX MDTA-2, ORANGE PARK, FL, 32065-0000

Previous balance		\$342.63
Payments		\$0.00
Credits	Page 3	-\$7.25
<b>Past due balance</b>		<b>\$335.38</b>
Regular monthly charges	Page 3	\$320.45
One-time charges	Page 3	\$10.00
Taxes, fees and other charges	Page 3	\$30.41
<b>New charges due Jan 01, 2025</b>		<b>\$360.86</b>

**Amount due \$696.24**

### Your account is past due

Your account is past due, so you may have been charged a late fee of \$10.00. To keep your account current, please pay the past due balance immediately.

### Need help?

Visit [business.comcast.com/help](https://business.comcast.com/help) or see page 2 for other ways to contact us.

## Your bill explained

- Your one-time charges are \$10.00 due to Late Fee charge(s).
- Any payments received or account activity after Dec 11, 2024 will show up on your next bill. View your most up-to-date account balance at [business.comcast.com/myaccount](https://business.comcast.com/myaccount).
- This page gives you a quick summary of your monthly bill. A detailed breakdown of your charges begins on page 3.

*EW-7835  
12/23/24*

Detach the bottom portion of this bill and enclose with your payment

Please write your account number on your check or money order

Do not include correspondence with payment



1100 NORTHPOINT PKWY W PALM  
BCH FL 33407-1937  
09330310 NO RP 11 20241211 NNNNNNNY 0000015 0005

EASTWEST COMMUNITIES  
3979 EAGLE LANDING PKWY  
BOX MDTA-2  
ORANGE PARK FL 32065-2065



Account number	<b>8495 74 144 1687294</b>
Past due balance	<b>\$335.38</b>
New charges due Jan 01, 2025	\$360.86
<b>Please pay</b>	<b>\$696.24</b>
Amount enclosed	\$

Make checks payable to Comcast  
Do not send cash

Send payment to  
COMCAST  
PO BOX 71211  
CHARLOTTE NC 28272-1211



<b>Past due balance</b>	<b>\$335.38</b>	
Previous balance	\$342.63	
<b>Credits</b>	<b>-\$7.25</b>	
RSN Fee - Adjustment	Dec 09	-\$7.25

<b>Regular monthly charges</b>	<b>\$320.45</b>
<b>Comcast Business</b>	<b>\$320.45</b>
<b>TV services</b>	<b>\$320.45</b>
TV Standard	\$74.95
Business Video	
CableCARD	✓
Qty 6 @ \$0.00 each	
Digital Adapter	✓
Equipment Fee	\$200.00
TV Box	
Broadcast TV Fee	\$34.00
Regional Sports Fee	\$11.50

**What's included?**

**TV:** Keep your employees informed and customers entertained.

This shows a service is included in your package: ✓

Visit [business.comcast.com/myaccount](https://business.comcast.com/myaccount) for more details



<b>One-time charges</b>	<b>\$10.00</b>	
<b>Other charges</b>	<b>\$10.00</b>	
Late Fee	Dec 11	\$10.00

<b>Taxes, fees and other charges</b>	<b>\$30.41</b>
<b>Other charges</b>	<b>\$0.15</b>
Regulatory Cost Recovery	\$0.15

<b>Taxes &amp; government fees</b>	<b>\$30.26</b>
Sales Tax	\$15.00
State Communications Services Tax	\$8.44
Local Communications Services Tax	\$6.82



**Important information regarding  
Comcast Business services and pricing  
Effective December 18, 2024**

Dear Comcast Business Customer:

At Comcast Business, we continue to make investments in our network, technology, and people to ensure we maintain a high-quality network for our customers. We strive to provide the best services and make significant efforts to help control your service-related costs.

From time to time, we re-evaluate our pricing structure due to programming, technology, and service improvements. As a result, monthly service charges and fees have been adjusted for the services below.

**Pricing updates based on your subscribed services will occur on December 18, 2024.  
Prices do not include applicable taxes and other fees.**

**Comcast Business Video**

Service	Current Monthly Service Charge:		New Monthly Service Charge Effective 12/18/2024:
Public View	\$20.00	>	<b>\$25.00</b>
Basic	\$50.95	>	<b>\$65.95</b>
Select	\$57.95	>	<b>\$72.95</b>
Variety	\$74.95	>	<b>\$89.95</b>
Standard	\$99.95	>	<b>\$114.95</b>
Preferred	\$124.95	>	<b>\$139.95</b>
Broadcast TV Fee (BTV)	Charges vary by location	>	Charges vary by location
Regional Sports Network (RSN)	Charges vary by location	>	Charges vary by location

**Hospitality Video**

Fees	Current Monthly Fee:		New Monthly Fee Effective 12/18/2024:
HBO	\$3.50	>	<b>\$5.50</b>
Showtime	\$3.50	>	<b>\$5.50</b>
Basic	\$2.00	>	<b>\$4.00</b>

**Comcast Business Voice**

Service	Current Monthly Service Charge:		New Monthly Service Charge Effective 12/18/2024:
Directory Listing Management Fee	\$6.00	>	<b>\$8.00</b>
Voice Network Investment Fee	\$6.00	>	<b>\$8.00</b>

**Comcast Business Internet**

Service	Current Monthly Service Charge:		New Monthly Service Charge Effective 12/18/2024:
Static IP (1)	\$24.95	>	<b>\$29.95</b>
Static IP (5)	\$29.95	>	<b>\$34.95</b>

# Hello Eagle Landng Athletic Club,

Thanks for choosing Comcast Business.

## Your bill at a glance

For 3979 EAGLE LANDING PKWY, OFC, ORANGE PARK, FL, 32065-2641

Previous balance		\$364.57
One-time EFT Payment - thank you	Dec 18	-\$364.57
<b>Balance forward</b>		<b>\$0.00</b>
Regular monthly charges	Page 3	\$369.85
One-time charges	Page 3	\$3.95
Taxes, fees and other charges	Page 3	\$1.87
<b>New charges</b>		<b>\$375.67</b>

**Amount due Jan 24, 2025 \$375.67**

Need help?  
Visit [business.comcast.com/help](https://business.comcast.com/help) or see page 2 for other ways to contact us.

## Your bill explained

- Regular monthly charges have increased by \$7.00 as a result of service change(s) made to Internet services and Comcast Business.
- Your one-time charges are \$3.95 due to Paper Statement Fee charge(s).
- This page gives you a quick summary of your monthly bill. A detailed breakdown of your charges begins on page 3.

Detach the bottom portion of this bill and enclose with your payment

Please write your account number on your check or money order

Do not include correspondence with payment

COMCAST BUSINESS

1100 NORTHPOINT PKWY W PALM  
BCH FL 33407-1937  
98330310 NO RP 03 20250103 MNNNNNNY 0000122 0001

EAGLE LANDNG ATHLETIC CLUB  
ATTN MATT BIAGETTI  
3989 EAGLE LANDING PKWY OFC  
ORANGE PARK FL 32065-2641

Account number	<b>8495 74 144 1354200</b>
Payment due	<b>Jan 24, 2025</b>
<b>Please pay</b>	<b>\$375.67</b>
Amount enclosed	\$

Make checks payable to Comcast  
Do not send cash



Send payment to  
COMCAST  
PO BOX 71211  
CHARLOTTE NC 28272-1211

<b>Regular monthly charges</b>		<b>\$369.85</b>
<b>Comcast Business</b>		<b>\$369.85</b>
<b>Internet services</b>		<b>\$369.85</b>
Business Internet 300+	\$309.95	
Static IP - 5	\$34.95	
Equipment Fee	\$24.95	
Internet		

**What's included?**

 **Internet:** Fast, reliable internet on our Gig-speed network

Visit [business.comcast.com/myaccount](https://business.comcast.com/myaccount) for more details

<b>One-time charges</b>		<b>\$3.95</b>
<b>Other charges</b>		<b>\$3.95</b>
Paper Statement Fee	Jan 03	\$3.95

<b>Taxes, fees and other charges</b>		<b>\$1.87</b>
<b>Taxes &amp; government fees</b>		<b>\$1.87</b>
Sales Tax		\$1.87



Champion Brands Inc.  
 PO BOX 56260  
 Jacksonville, FL 32241  
 (904)-268-1220  
 Tue Jan 21, 2025 3:08 PM

Account: 01344 Invoice#: 3533741 PO#: S VILLAGE COMMUNITY DEV License : 2001256 Expires N/A  
 EAGLE LANDING SWIM AND Load : 281  
 3975 EAGLE LANDING PARKWA Terms : FINTECH  
 ORANGE PARK, FL 32065 Driver : 81 - Z. GONZALES  
 (904) 291-3535 Salesrep: 801 - HUNTER LABBIE

ITEM#	QTY	DESCRIPTION	U.P.C.	Disc	D.PRICE	DEP	EXT
57274	2	LITE	034100003760	0.00	29.50	0.00	59.00
		LITE ALUMINUM 24/16 CAN					
90000	1	RB EDITIONS	611269235685	0.00	41.50	0.00	41.50
		RED BULL BLUE EDITION 24/8.4 CAN					
90035	1	RB ENERGY DRIN	611269991000	0.00	41.50	0.00	41.50
		RED BULL ENERGY DRINK 80Z SINGLES					
90036	1	RB SUGAR FREE	611269101713	0.00	41.50	0.00	41.50
		RED BULL SUGAR FREE 80Z SINGLES					

Beer: 2 + 0 Kegs \$59.00  
 Wine & Liq: 0 \$0.00  
 Soft Drink: 3 \$124.50  
 Misc: 0 \$0.00  
 Credits: 0 \$0.00

*Swim + Tennis*

Total Selling Units:	74
Total Sales	183.50
Total Discount	-0.00
Total Content	183.50
Total Deposit	0.00
Total Credits	0.00
Over/Short	0.00
Invoice Total	183.50

5510-200

~~200-1342 - 59.00~~  
 (Beer)

~~200-1360 - 124.50~~  
 (Tennis)

5500-200

I ACCEPT THIS PRODUCT DELIVERY IN SALEABLE CONDITION.  
 YOUR SIGNATURE IS ACCEPTANCE OF ALL ABOVE ITEMS. PLEASE CHECK CAREFULLY.  
 Thank you!

Customer Signature:

Driver Signature:

*Handwritten signature: [unclear]*

*Handwritten signature: [unclear]*

*Handwritten signature: F. ONZO*



Champion Brands Inc.  
 PO BOX 56260  
 Jacksonville, FL 32241  
 (904)-268-1220  
 Tue Jan 21, 2025 3:08 PM

Account: 01344      Invoice#: 3533740      PO#:      S VILLAGE COMMUNITY DEV      License : 2001256 Expires N/A  
 EAGLE LANDING SWIM AND      Load : 281  
 3975 EAGLE LANDING PARKWA      Terms : FINTECH  
 ORANGE PARK, FL 32065      Driver : 81 - Z. GONZALES  
 (904) 291-3535      Salesrep: B01 - HUNTER LABBIE

ITEM#	QTY	DESCRIPTION	U.P.C.	Disc	D.PRICE	DEP	EXT
600006	1	WATERBIRD	860005649570	0.00	49.45	0.00	49.45
		6/4/12 VODKA TRANSFUS MB VODKA TRANS 6/4					

Beer: 0 + 0 Kegs      \$0.00  
 Wine & Liq: 1      \$49.45  
 Soft Drink: 0      \$0.00  
 Misc: 0      \$0.00  
 Credits: 0      \$0.00

*Sum/Totals*  
 5530-200  
~~200-1346~~  
 \$49.45

Total Selling Units:	6
Total Sales	49.45
Total Discount	-0.00
Total Content	49.45
Total Deposit	0.00
Total Credits	0.00
Over/Short	0.00
<b>Invoice Total</b>	<b>49.45</b>

I ACCEPT THIS PRODUCT DELIVERY IN SALEABLE CONDITION.  
 YOUR SIGNATURE IS ACCEPTANCE OF ALL ABOVE ITEMS. PLEASE CHECK CAREFULLY.  
 Thank you!

Customer Signature:  1/29/25  
 Driver Signature: 

Driver Signature:   
 81 - Z. GONZALES

SECTION 561.42, FLORIDA STATUTES, AND RULE 61A-1.010, PRODUCTS DAMAGED BY VENDORS SHALL NOT BE RETURNED TO THE DISTRIBUTOR FOR CREDIT OR EXCHANGE AND WILL BE THE VENDOR'S LIABILITY. VENDORS SHALL NOTIFY DISTRIBUTORS OF DAMAGED PRODUCTS RECEIVED FROM THE DISTRIBUTOR WITHIN 10 DAYS AFTER DELIVERY IN ORDER TO OBTAIN A CREDIT OR EXCHANGE. A TRANSACTION RECORD OF ALL EXCHANGES MUST BE MADE BY THE DISTRIBUTOR.

SOUTHERN GLAZER'S OF FL  
4440 OLD TAMPA HIGHWAY  
LAKELAND, FLORIDA  
33811

REMIT TO:  
SOUTHERN GLAZER'S OF FL  
P.O. BOX 947921  
ATLANTA, GA 30394-7921  
1-866-375-9555



INVOICE NUMBER	3657439		
ACCOUNT NUMBER	15708		
ROUTE	516	STOP	17

EAGLE LANDING SWIM AND TENNIS  
3975 EAGLE LANDING PARKWAY  
ORANGE PARK FL 32065

EAGLE LANDING SWIM AND TENNIS  
3975 EAGLE LANDING PARKWAY  
ORANGE PARK FL 32065

**C.O.D.**

S  
H  
I  
P  
T  
O

DUPLICATE

C O D C.O.D. FINTECH

PAGE 1 OF 1  
1500 3 14

LAKELAND-NIGHT BILL

LICENSE NUMBER	SALES PERSON	DELVY INSTRUCTIONS:	PHONE NUMBER	INVOICE DATE
20-01256	166	P.O.#:	904-291-3535	1/23/2025

LOC	CASES	BTL	SIZE	DESCRIPTION	PACK	W-COC	S-LOC	PRODUCT CODE	NET BTL PRICE	UNIT PRICE	DRY CODE	UNIT DISCOUNT	NET AMOUNT
	1		1.0L	CASAMIGOS TEQUILA REPOSADO 80	6	84		446127	57.90	409.50	001	62.10	347.40
	1		1.0L	DUBOUCHETT PEACH SCHNAPPS 30	12			708	4.75	84.00	080	27.00	57.00
	1		1.0L	MAKERS MARK BOURBON 90	12		21653	9998	42.73	42.73	003		42.73
<b>C O D</b>													
<p>Swim/Tennis</p> <p>5530-200 - LIQVOR - 200-1346</p> <p>Rec'd 1/22/25</p> <p>\$ 447.13</p>													
TOTAL # BTL:					19					YTD TOTAL DISCOUNT:		65.10	

Thank You For Your Business

PAGE TOTAL	CASES ORDER TOTAL	PAGE TOTAL	BOTTLES ORDER TOTAL	WINE GALLONS	LIQUR GALLONS	BEER GALLONS	CUSTOMER	PAGE	GROSS TOTAL	TOTAL DISCOUNT	PAY THIS AMOUNT
2	2	1	1		5.02		EAGLE LANDING SWIM AND TE	1	536.23	89.10	C O D 447.13
CARTON	DRIVER	LOADED	<small>Buyer represents that it is authorized under applicable law to purchase all the products delivered in this invoice and that all such products were ordered by it and have been received without any damage, notice noted on bottles or cans of delivery. SELLER EXPRESSLY DISCLAIMS ANY WARRANTY, INCLUDING OF MERCHANTABILITY OR FITNESS FOR A PARTICULAR PURPOSE. BUYER WAIVES CONSEQUENTIAL, PUNITIVE, TREBLE, OR STATUTORY DAMAGES OR PENALTIES. The parties agree to arbitrate any dispute between them on an individual basis in Miami, FL before the American Arbitration Association in accordance with its Commercial Arbitration Rules. The parties each waive the right to seek or receive an FRSA representative of its participation in a class or collective action in any legal proceeding between them.</small>				INVOICE NO.	CUSTOMER NO.	NET AMOUNT	<small>If not paid according to these terms, seller may reserve credit, credit discount, resale or other remedies in accordance with applicable law. Payment checks are subject to the terms of C.O.D. or other terms set forth herein. Any check returned will create interest at the rate of the highest rate permitted by law or 15% per month (whichever is greater) until paid in full. The liability of the parties shall be limited to the amount of the invoice. The liability of the parties shall be limited to the amount of the invoice. The liability of the parties shall be limited to the amount of the invoice.</small>	
2			3657439	15708	447.13	DELIVERY RECEIPT NO CLAIMS FOR SHORTAGES WILL BE ALLOWED UNLESS INSPECTED AND NOTED AT TIME OF DELIVERY X X		DUE DATE		1/23/2025	



3176 Old Jennings Road, Middleburg, FL 32068-3907



Account Summary:

Thank you for keeping your account current!

Previous Statement Balance	\$759.67
Payments	-\$759.67
Current Charges Due 01/30/2025	\$1,003.56
<b>Total Amount Due</b>	<b>\$1,003.56</b>

Account Information

Bill Date: 01/09/25 Billing Cycle: 4  
 Account Number: A00013323  
 South Village CDD  
 3965 Eagle Landing Parkway Pool House & Cabana, Orange Park

Customer Service (8am-5pm M-F)  
 (904) 272-5999

Online  
<https://www.clayutility.org/>

All accounts not paid by due date are subject to a \$3.42 late fee.

X  
 @CCUA

Email  
[billing@clayutility.org](mailto:billing@clayutility.org)

Facebook  
 CCUAFL

Current Charges	Rate	Usage	Total
<b>Water</b>			
Potable Base Charge			\$65.50
Potable Water Usage - Tier 1	\$2.71	96.902 kGal	\$262.60
AW5 Surcharge			\$1.22
<b>Sewer</b>			
Sewer Base Charge			\$149.03
Sewer Usage Charge - Tier 1	\$5.42	96.902 kGal	\$525.21
<b>Total Current Charges</b>			<b>\$1,003.56</b>

Usage Profile (KGAL = 1,000 gallons)

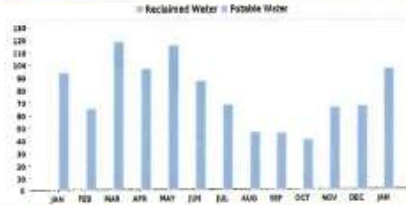

7800-550 1,003.56  
 7581-800 2.45 Convenience Fee

Meter Readings

Water Meter		
Read Dates: 11/27/24 - 01/01/25		Days: 35
Meter: 73894558	Previous Read: 9,791,504	Current Read: 9,888,406

PAID BY PHONE 1/29  
 CONF #711261

*Handwritten note:*  
 550-700  
 85  
 1/28/25

Message Board

Water Quality Reports are sent by email, online at [www.clayutility.org/wqr/WQR.pdf](http://www.clayutility.org/wqr/WQR.pdf), or at our office. To receive a copy by mail, contact 904-272-5999.

Retain this portion for your records.

Please return bottom portion along with your payment to Clay County Utility Authority.



Clay County Utility Authority  
 3176 Old Jennings Road  
 Middleburg, FL 32068-3907

Bill Date: 01/09/25  
 Due Date: 01/30/25  
 Account Number: A00013323  
 Service Address: 3965 Eagle Landing Parkway Pool House & Cabana, Orange Park

If paid after due date the account is subject to \$3.42 late fee.

**Total Amount Due \$1,003.56**

1,006.01

Donate to Lend a Helping Hand Program:  
 \$1  \$5  \$10  Other \_\_\_\_\_

AY10110A  
 2000000456 17/5

SOUTH VILLAGE CDD  
 3989 EAGLE LANDING PKWY  
 ORANGE PARK, FL 32065, UNITED STATES



CLAY COUNTY UTILITY AUTHORITY  
 3176 OLD JENNINGS ROAD  
 MIDDLEBURG, FL 32068-3907

0A00013323 0000100356 013025 0 0 4





3601 Rosent Blvd.  
 Jacksonville, FL 322  
 (904) 645-8283  
 NFSales.net

EAGLE LANDING SWIM A  
 3975 EAGLE LANDING P  
 ORANGE PARK, FL 3206  
 BEV2001256  
 LAURA

Stacy McClellan

Fintech

Date	Invoice	LoadSheet	Vendor	PO Num
01/28/2025	4100016	292326		20764869

Route	Customer	Delivery	Salesman
1504 TUES	121162	AMATHEWS	AP1_11825

ID	QTY	PRODUCT	PRICE	DEP	DISC	NET	TOTAL
10	(2)	SINGLE UNIT PICKUP 12oz CAN/B	\$1.80			\$3.60	(41.66)
111	(1)	BUD 2/12 C	\$27.00			\$27.00	(427.00)
52161	(3)	GI IPA 20/12 2/15 C	\$33.65			\$100.95	(100.95)
2624	1	PRIME HYDRATION LEMON LIME 12	\$16.00		\$2.00	\$14.00	\$16.00
2628	1	PRIME HYDRATION ROTATIONAL CM	\$16.00		\$2.00	\$14.00	\$16.00
15650	1	NORDIC BLUE PREMIUM WATER 12p	\$13.00			\$13.00	\$13.00
1098	1	GOAT FUEL WATERMELON PUNCH 12	\$24.00			\$24.00	\$24.00
513	3	BUD LT BULTCAGE	\$24.99			\$74.97	\$74.40
9282	1	STELLA 2/12 12oz C	\$33.35			\$33.35	\$33.35

*Handwritten signature in blue ink.*

9 2 BEER (1.6875) Gallon \$0.00 \$4.00

*Rec'd @ 1/28/25*

Total \$47.14  
 Charges \$175.75  
 Credits \$128.61  
 Total \$47.14

*Order*  
~~200-1360~~ - \$69.00  
 5500-200

~~200-1342~~ < 21.84  
*Base*  
 5510-200  
 CREDIT

9I - South Village CDD dba Eagle Landing      Pg 1  
 1000 - Golf Operating Account  
 Check Register for Jan 1/25 thru Jan 31/25  
 Regular Checks

Check	Issued to:	Date	Check Amount
15661	1492 INC/PREMIER CAPITAL CIGAR	Jan 3/25	437.31
15662	ACUSHNET COMPANY	Jan 3/25	2,629.59
15663	CAPITOL DOCUMENT SOLUTIONS	Jan 3/25	224.35
15664	CINTAS CORPORATION	Jan 3/25	961.38
15665	DIRECTV	Jan 3/25	434.22
15666	DLL FINANCE LLC	Jan 3/25	297.14
15667	FLORIDA STATE GOLF ASSOCIATION	Jan 3/25	209.00
15668	HARRELL S LLC	Jan 3/25	2,012.00
15669	ODP BUSINESS SOLUTIONS, LLC	Jan 3/25	205.74
15670	PAUL MURRAY OIL INC	Jan 3/25	755.46
15671	PRECISION SMALL ENGINE CO INC	Jan 3/25	1,057.96
15672	SHARP ENERGY	Jan 3/25	711.55
15673	SYSKO JACKSONVILLE INC	Jan 3/25	1,847.72
15674	TABLE TOP LINEN RENTAL	Jan 3/25	193.68
15675	TROON GOLF LLC	Jan 3/25	481.50
15676	TRIGON TURF SCIENCES	Jan 3/25	3,121.12
15677	US FOODSERVICE	Jan 3/25	11,239.29
15678	ACUSHNET COMPANY	Jan 9/25	239.27
15679	ADIDAS AMERICA INC	Jan 9/25	1,080.00
15680	CINTAS CORPORATION	Jan 9/25	326.22
15681	CINTAS FIRE PROTECTION	Jan 9/25	1,409.18
15682	FLORIDA S FIRST COAST OF GOLF INC	Jan 9/25	382.08
15683	GRANITE TELECOMMUNICATIONS	Jan 9/25	92.65
15684	KIMBALL-MIDWEST	Jan 9/25	401.75
15685	PTE Golf, LLC	Jan 9/25	399.97
15686	SYSKO JACKSONVILLE INC	Jan 9/25	814.52
15687	TABLE TOP LINEN RENTAL	Jan 9/25	193.68
15688	TROON GOLF LLC	Jan 9/25	445.00
15689	US FOODSERVICE	Jan 9/25	6,817.34
15690	VEREENS TURF PRODUCTS	Jan 9/25	30.00
15691	ACUSHNET COMPANY	Jan 16/25	483.60
15692	DARLING INGREDIENTS INC	Jan 16/25	510.00
15693	ECOLAB PEST ELIM DIV	Jan 16/25	279.96
15694	EZLINKS GOLF	Jan 16/25	737.50
15695	GT GOLF SUPPLIES	Jan 16/25	291.76
15696	HAHN JIM	Jan 16/25	184.80
15697	HARRELL S LLC	Jan 16/25	560.00
15698	HELGET GAS PRODUCTS INC	Jan 16/25	62.45
15699	HOME DEPOT CREDIT SERVICES	Jan 16/25	660.47
15700	ODP BUSINESS SOLUTIONS, LLC	Jan 16/25	25.90
15701	PUKKA LLC	Jan 16/25	849.32
15702	SYSKO JACKSONVILLE INC	Jan 16/25	1,540.03
15703	TABLE TOP LINEN RENTAL	Jan 16/25	225.50
15704	TORO NSN	Jan 16/25	282.00
15705	TRIGON TURF SCIENCES	Jan 16/25	1,282.61
15706	US FOODSERVICE	Jan 16/25	4,711.29
15707	WESCOTURF SUPPLY INC	Jan 16/25	288.14

9I - South Village CDD dba Eagle Landing      Pg 2  
 1000 - Golf Operating Account  
 Check Register for Jan 1/25 thru Jan 31/25  
 Regular Checks

Check	Issued to:	Date	Check Amount
15708	ACUSHNET COMPANY	Jan 23/25	3,307.93
15709	CINTAS CORPORATION	Jan 23/25	568.02
15710	DLL FINANCE LLC	Jan 23/25	245.37
15711	EZLINKS GOLF	Jan 23/25	737.50
15712	PAUL MURRAY OIL INC	Jan 23/25	417.42
15713	SHARP ENERGY	Jan 23/25	744.80
15714	SITEONE LANDSCAPE SUPPLY LLC	Jan 23/25	122.54
15715	SYSKO JACKSONVILLE INC	Jan 23/25	2,951.37
15716	TABLE TOP LINEN RENTAL	Jan 23/25	225.50
15717	TRIGON TURF SCIENCES	Jan 23/25	986.88
15718	US FOODSERVICE	Jan 23/25	5,407.69
15719	WESCOTURF SUPPLY INC	Jan 23/25	2,875.31
15720	ACUSHNET COMPANY	Jan 30/25	96.14
15721	BRENT T BLAKE	Jan 30/25	99.11
15722	BULK AGGREGATE GOLF	Jan 30/25	1,647.52
15723	CAPITOL DOCUMENT SOLUTIONS	Jan 30/25	165.93
15724	CINTAS CORPORATION	Jan 30/25	898.04
15725	HELGET GAS PRODUCTS INC	Jan 30/25	143.22
15726	MARTCO	Jan 30/25	457.60
15727	ODP BUSINESS SOLUTIONS, LLC	Jan 30/25	238.74
15728	STERLING CUT GLASS	Jan 30/25	313.54
15729	SYSKO JACKSONVILLE INC	Jan 30/25	1,887.86
15730	TABLE TOP LINEN RENTAL	Jan 30/25	225.50
15731	TWC SERVICES	Jan 30/25	793.33
15732	US FOODSERVICE	Jan 30/25	4,373.46
			-----
Total Regular Checks Issued			82,356.32

===== End of Report =====

**INVOICE**

1492 INC/PREMIER/TUBEAUX  
732 Avenida Majorca Unit A  
Laguna Woods, CA 92637

arthur@pccigar.com  
+1 (800) 511-7757  
www.pccigar.com

2275-000 437.60  
1320-000 (.29)

**EAGLE LANDING GC (GOLF SHOP)**

**Bill to**  
ERNIE CRUZ  
EAGLE LANDING GC (GOLF SHOP)  
3989 Eagle Landing Parkway  
Orange Park, FL 32065

**Ship to**  
ERNIE CRUZ  
EAGLE LANDING GC (GOLF SHOP)  
3989 Eagle Landing Parkway  
Orange Park, FL 32065

**Shipping info**

Ship via: UPS  
Ship date: 12/13/2024  
1ZEX14340314655900

**Invoice details**

Invoice no.: 18999  
Terms: Net 20  
Invoice date: 12/13/2024  
Due date: 01/02/2025

**PURCHASE ORDER: 2044TUB**

#	Date	Product or service	SKU	Description	Qty	Rate	Amount
1.	12/13/2024	RYJ TUB GRAN TORO TUBE	1300000	1300000 - ROMEO y JULIETA GRAN TORO TUBE (5 Cigars) 40 TOTAL	8	\$51.98	\$415.84

Subtotal \$415.84

Contact 1492 INC to pay.

Shipping \$21.47

**Note to customer**

**Total \$437.31**

STATE TOBACCO TAX PAID BY TUBEAUX OR 1492 INC LISTED UNDER SALES TAX ON EACH INVOICE OR AS A LINE ITEM.

*Handwritten signatures and notes:*  
12/13/24  
1320-100





**ACUSHNET COMPANY**  
 P.O. BOX 965 FAIRHAVEN, MA 02719-0965  
 Tel: 800-225-8500 Fax: 508-979-3913



**INVOICE**  
 Currency: USD

Tax No: 04-2591836

Invoice No 919182680		Invoice Date 10/31/24	Shipment Date 10/31/24	Order Date 08/02/24
Order No 3024596877	Whs 05A	Delivery No 59422278	Customer P.O. AT ONCE LADIES	Account No US00027669   US00040574

**Sold To**  
 SOUTH VILLAGE COMMUNITY DEVELOP  
 DISTRICT DBA EAGLE LANDING GOLF CLUB  
 3989 EAGLE LANDING PKWY  
 ORANGE PARK FL 32065-2641

**Ship To**  
 EAGLE LANDING GOLF CLUB  
 ATTN PRO SHOP  
 3989 EAGLE LANDING PKWY  
 ORANGE PARK FL 32065-2641

**Remit To**  
 Acushnet Company  
 P.O. Box 830334  
 Philadelphia, PA 19182-0334

**Payment Terms**  
 Net 75 Days  
 Payment Discount  
 5% 60 Days  
 Delivery Method  
 FedEx Ground

**Due Date**  
 01/14/25

**Frt Acct No**

Item No	Shipped	U/M	Unit	Disc	Disc	Disc	Cstm	Net	Extended
---------	---------	-----	------	------	------	------	------	-----	----------

Item No	Shipped	U/M	Unit	Disc	Disc	Disc	Cstm	Net	Extended	
<b>** Custom Apparel**</b>										
Logo Name: Eagles Landing										
Logo ID: 168169										
Logo Placement: LEFT SLEEVE/LEFT CHEST										
27940C-S	1	EA		\$34.50	4%			\$5.00	\$38.12	\$38.12
Sleeveless Shirt Wm Light Blue										
Total Shipped Qty. 1										

Net Order Total	\$38.12
Shipping and Handling Total	\$2.61
<b>Total Invoice</b>	<b>\$40.73</b>

If paid by 12/30/24 deduct discount of \$ 1.91 ( 5.00 % ) -- REMIT \$38.82

*[Handwritten signatures and initials]*  
 11/2/24  
 2275-000  
~~1320-100~~

Effective December 1, 2024 Acushnet Golf will no longer mail invoice and statement documents.  
 Please contact us at 800-225-8500 to set-up electronic delivery today.  
 You can access your account online at Acushnetgolf.com.

Invoices not paid within thirty (30) days of due date shall incur a service charge at the rate of the lesser of one and one-half percent (1.5%) per month or the highest rate permitted by law on any outstanding overdue balance from original due date.  
**SEE REVERSE SIDE FOR CONDITIONS OF SALE.**



**ACUSHNET COMPANY**  
 P.O. BOX 965 FAIRHAVEN, MA 02719-0965  
 Tel: 800-225-8500 Fax: 508-979-3913

100/1325



**INVOICE**  
 Currency: USD

Tax No: 04-2591836

Invoice No 919229423		Invoice Date 11/13/24	Shipment Date 11/13/24	Order Date 10/31/24
Order No 3028069469	Who OSP	Delivery No 59682311	Customer P.O. GLOVE FILL/ERNIE	Account No US00027669 \ US00040574

**Sold To**  
 SOUTH VILLAGE COMMUNITY DEVELOP  
 DISTRICT DBA EAGLE LANDING GOLF CLUB  
 3989 EAGLE LANDING PKWY  
 ORANGE PARK FL 32065-2641

**Ship To**  
 EAGLE LANDING GOLF CLUB  
 ATTN PRO SHOP  
 3989 EAGLE LANDING PKWY  
 ORANGE PARK FL 32065-2641

**Remit To**  
 Acushnet Company  
 P.O. Box 830334  
 Philadelphia, PA 19182-0334

**Payment Terms**  
 Net 60 Days  
 Payment Discount  
 NA  
**Delivery Method**  
 FedEx Ground

**Due Date**  
 01/12/25

**Frt Acct No**

Item No	Shipped	U/M	Unit	Disc	Disc	Disc	Cstm	Net	Extended
Description									
6597E-101-L Perma-Soft MRL Pearl	12	EA	\$12.00	2%				\$11.76	\$141.12
6597E-101-M Perma-Soft MRL Pearl	12	EA	\$12.00	2%				\$11.76	\$141.12
6597E-101-XL Perma-Soft MRL Pearl	12	EA	\$12.00	2%				\$11.76	\$141.12
6597E-101-XXL Perma-Soft MRL Pearl	6	EA	\$12.00	2%				\$11.76	\$70.56
6598E-101-L Perma-Soft MCL Pearl	12	EA	\$12.00	2%				\$11.76	\$141.12
6598E-101-M Perma-Soft MCL Pearl	6	EA	\$12.00	2%				\$11.76	\$70.56
6598E-101-ML Perma-Soft MCL Pearl	6	EA	\$12.00	2%				\$11.76	\$70.56
6598E-101-XL Perma-Soft MCL Pearl	6	EA	\$12.00	2%				\$11.76	\$70.56
<b>Total Shipped Qty.</b>	<b>72</b>								

**Net Order Total** \$846.72  
**Total Invoice** \$846.72

11/19/24

Effective December 1, 2024 Acushnet Golf will no longer mail invoice and statement documents.  
 Please contact us at 800-225-8500 to set-up electronic delivery today.  
 You can access your account online at Acushnetgolf.com.

Invoices not paid within thirty (30) days of due date shall incur a service charge at the rate of the lesser of one and one-half percent (1.5%) per month or the highest rate permitted by law on any outstanding overdue balance from original due date.  
**SEE REVERSE SIDE FOR CONDITIONS OF SALE.**





**ACUSHNET COMPANY**  
 P.O. BOX 965 FAIRHAVEN, MA 02719-0965  
 Tel: 800-225-8500 Fax: 508-979-3913



**INVOICE**  
 Currency: USD

Tax No: 04-2591836

Invoice No 819241424		Invoice Date 11/15/24	Shipment Date 11/15/24	Order Date 11/04/24
Order No 3025080452	Whs 04B	Delivery No 59895544	Customer P.O. #1 GIFT GOLF/ERNIE	Account No US00027669 \ US00040574

**Sold To**  
 SOUTH VILLAGE COMMUNITY DEVELOP  
 DISTRICT DBA EAGLE LANDING GOLF CLUB  
 3989 EAGLE LANDING PKWY  
 ORANGE PARK FL 32065-2641

**Ship To**  
 EAGLE LANDING GOLF CLUB  
 ATTN PRO SHOP  
 3989 EAGLE LANDING PKWY  
 ORANGE PARK FL 32065-2641

**Remit To**  
 Acushnet Company  
 P.O. Box 830334  
 Philadelphia, PA 19182-0334

**Payment Terms**  
 Net 60 Days  
 Payment Discount  
 NA  
 Delivery Method  
 FedEx Ground

**Due Date**  
 01/14/25

**Frt Acct No**

Item No	Shipped	U/M	Unit	Disc	Disc	Cstm	Net	Extended
T2028S-2DHD Titl Pro V1 Holiday 2-Dozen	6	P24	\$75.50	2%			\$73.99	\$443.94
T2048S-2DHD Titl Pro V1x Holiday 2-Dozen	6	P24	\$75.50	2%			\$73.99	\$443.94
<b>Total Shipped Qty.</b>	<b>12</b>							

<b>Net Order Total</b>	<b>\$887.88</b>
<b>Shipping and Handling Total</b>	<b>\$35.92</b>
<b>Total Invoice</b>	<b>\$923.80</b>

1325-100

Received 6 and entered in inventory.  
 Remaining 6 in route.

Effective December 1, 2024 Acushnet Golf will no longer mail invoice and statement documents.  
 Please contact us at 800-225-8500 to set-up electronic delivery today.  
 You can access your account online at Acushnetgolf.com.

Invoices not paid within thirty (30) days of due date shall incur a service charge at the rate of the lesser of one and one-half percent (1.5%) per month or the highest rate permitted by law on any outstanding overdue balance from original due date.  
**SEE REVERSE SIDE FOR CONDITIONS OF SALE.**



**Acushnet Company**

P.O. BOX 965 FAIRHAVEN, MA. 02719-0965  
Tel. 800-225-8500 Fax: 508-879-3913

100 / 1325  
*[Handwritten signature]*



2275-000 461.88  
1325-000 .02

**INVOICE**  
Currency: USD

Tax No.: 04-2591836

Invoice No 919248957		Invoice Date 11/18/24	Shipment Date 11/18/24	Order Date 10/31/24
Order No 3025070145	Whs 04B	Delivery No 59741579	Customer P.O. NOV STOCK/ERNIE	Account No US00027669   US00040574

**Sold To**  
SOUTH VILLAGE COMMUNITY DEVELOP  
DISTRICT DBA EAGLE LANDING GOLF CLUB  
3989 EAGLE LANDING PKWY  
ORANGE PARK FL 32065-2641

**Ship To**  
EAGLE LANDING GOLF CLUB  
ATTN PRO SHOP  
3989 EAGLE LANDING PKWY  
ORANGE PARK FL 32065-2641

**Remit To**  
Acushnet Company  
P.O. Box 830334  
Philadelphia, PA 19182-0334

**Payment Terms** **Due Date**  
Net 60 Days 01/17/25  
**Payment Discount**  
NA  
**Delivery Method** **Frnt Acct No**  
FedEx Ground

Item No Description	Shipped Qty	U/M	Unit Price	Disc 1	Disc 2	Disc 3	Cstrn Chgs	Net Price	Extended
T2028S-2DHD Titl Pro V1 Holiday 2-Dozen	6	P24	\$75.50	2%				\$73.99	\$443.94
<b>Total Shipped Qty.</b>	<b>6</b>								

<b>Net Order Total</b>	\$443.94
<b>Shipping &amp; Handling Total</b>	\$17.96
<b>Total Invoice</b>	\$461.90

*[Handwritten signature]*  
11/30/24

Invoices not paid within thirty (30) days of due date shall incur a service charge at the rate of the lesser of one and one-half percent (1.5%) per month or the highest rate permitted by law on any outstanding overdue balance from original due date. See enclosed terms and conditions page.





**ACUSHNET COMPANY**  
 P.O. BOX 965 FAIRHAVEN, MA 02719-0965  
 Tel: 800-225-8500 Fax: 508-879-3913



**INVOICE**  
 Currency: USD

Tax No: 04-2591836

Invoice No 919396522		Invoice Date 12/12/24	Shipment Date 12/12/24	Order Date 08/02/24
Order No 3024607256	Whs 05A	Delivery No 58108614	Customer P.O. 12/15 LADIES	Account No US00027669 \ US00040574

**Sold To**  
 SOUTH VILLAGE COMMUNITY DEVELOP  
 DISTRICT DBA EAGLE LANDING GOLF CLUB  
 3889 EAGLE LANDING PKWY  
 ORANGE PARK FL 32065-2641

**Ship To**  
 EAGLE LANDING GOLF CLUB  
 ATTN PRO SHOP  
 3889 EAGLE LANDING PKWY  
 ORANGE PARK FL 32065-2641

**Remit To**  
 Acushnet Company  
 P.O. Box 830334  
 Philadelphia, PA 19182-0334

**Payment Terms**  
 Net 75 Days  
 Payment Discount  
 5% 60 Days  
 Delivery Method  
 FedEx Ground

**Due Date**  
 02/25/25

**Frt Acct No**

Item No	Shipped	U/M	Unit	Disc	Disc	Disc	Cstm	Net	Extended
26892-L Knit Skort Wmn White	2	EA	\$44.00	4%				\$42.24	\$84.48
26892-M Knit Skort Wmn White	2	EA	\$44.00	4%				\$42.24	\$84.48
26892-S Knit Skort Wmn White	1	EA	\$44.00	4%				\$42.24	\$42.24
26892-XL Knit Skort Wmn White	1	EA	\$44.00	4%				\$42.24	\$42.24
33443-S W Arl Knt Prfm Skrt Bry Prmt	1	EA	\$47.50	4%				\$45.60	\$45.60
33447-S W Arl Knt Prfm Skrt Skywy Prmt	1	EA	\$47.50	4%				\$45.60	\$45.60
<b>Total Shipped Qty.</b>	<b>8</b>								

**Net Order Total** \$344.64  
**Shipping and Handling Total** \$11.80  
**Total Invoice** \$356.44

If paid by 02/10/25 deduct discount of \$ 17.23 ( 5.00 %) – REMIT \$339.21

2275-000 356.48  
 1320-000 (.04)

1320-100

Effective December 1, 2024 Acushnet Golf will no longer mail invoice and statement documents.  
 Please contact us at 800-225-8500 to set-up electronic delivery today.  
 You can access your account online at Acushnetgolf.com.

Invoices not paid within thirty (30) days of due date shall incur a service charge at the rate of the lesser of one and one-half percent (1.5%) per month or the highest rate permitted by law on any outstanding overdue balance from original due date.  
 SEE REVERSE SIDE FOR CONDITIONS OF SALE.



**CONTRACT INVOICE**

Invoice Number: 470776  
 Invoice Date: 12/13/2024

**Bill To:** South Village Community Development District dba Eagle Landing Golf Club  
 3989 Eagle Landing Parkway  
 Orange Park, FL 32065

**Customer:** South Village Community Development District dba Eagle Landing Golf Club  
 3989 Eagle Landing Parkway  
 Orange Park, FL 32065

Account No	Payment Terms	Due Date	Invoice Total	Balance Due	
SV00	Net 30	01/12/2025	\$ 224.35	<b>\$ 224.35</b>	
<b>Invoice Remarks</b>					
Contract Number	Contact	Contract Amount	P.O. Number	Start Date	Exp. Date
SV00-01	Joe Hallfko 904-291-5600 #3 #6	\$ 211.99		02/13/2018	
<b>Contract Remarks</b>					
Lease includes 3,000 b/w copies per month.					

**Summary:**

Contract base rate charge for this billing period	\$0.00
Contract overage charge for the 11/13/2024 to 12/12/2024 overage period	\$206.04 **
Supply Shipping	\$5.95

**Detail:**

**Equipment included under this contract**

**Konica Minolta/C368**

Number	Serial Number	Base Adj.	Location
EQ16935	A7PU017004327	\$0.00	South Village Community Development District dba Eagle Landing Golf Club 3989 Eagle Landing Parkway Orange Park, FL 32065

Meter Type	Meter Group	Begin Meter	End Meter	Credits	Total	Covered	Billable	Rate	Overage
BW	EQ16935 - BW	182,407	184,029		1,622	3,000	0	\$0.013000	\$0.00
Color	EQ16935 - Cok	177,016	179,056		2,040	0	2,040	\$0.101000	\$206.04
									\$206.04

*500-7340*  
*[Signature]*  
 12/13/24

Tax ID#26-3755218  
 DUNS #004769165

Thank you for your business!

Invoice Subtotal:	<u>\$211.99</u>
FL	<u>\$12.36</u>
Total Tax:	<u>\$12.36</u>
<b>Invoice Total:</b>	<b>\$224.35</b>



REMIT PAYMENT TO:  
 CINTAS CORP  
 P.O. BOX 630910  
 CINCINNATI, OH 45263-0910

VIEW & PAY YOUR BILLS ONLINE:  
 WWW.CINTAS.COM/MYACCOUNT

CUSTOMER SVC/BILLING 833-290-0514  
 CINTAS FAX # 904-741-6116  
 PAYMENT INQUIRY 904-741-4525

INVOICE

SHIP TO: EAGLE LANDING GOLF CLUB  
 3989 EAGLE LANDING PKWY  
 ORANGE PARK, FL 32065-2641

INVOICE # 4215687234  
 INVOICE DATE 12/24/2024

BILL TO: EAGLE LANDING GOLF CLUB  
 3989 EAGLE LANDING PKWY  
 ORANGE PARK, FL 32065-2641

SOLD TO # 22390656  
 PAYER # 22385762  
 PAYMENT TERMS NET 10 EOM  
 SORT # 02800003369  
 CINTAS ROUTE 53 / DAY 2 / STOP 011

EMPA/LOCK#	MATERIAL	DESCRIPTION	FREQ	EXCH	QTY	UNIT PRICE	LINE TOTAL	TAX
	X20023	SIG HRDWD WHT LRG-	01	F	12	9.520	114.24	Y
	X2700	TERRY TOWEL - WHITE-	01	F	320	0.202	64.64	Y
	X2700	TERRY TOWEL - WHITE-	L 01	F	29	0.561	17.43	N
	X27026	SIG AIR SVC	01	F	21	3.867	81.21	Y
	X27097	SIG TRASHCAN DSP ALU-	01	F	24	1.190	28.56	Y
	X2873	BIB APRON-BLACK-	01	F	60	0.444	26.64	Y
	X2873	BIB APRON-BLACK-	L 01	F	1	9.261	9.26	N
	X6680	DISP URINAL MAT SVC	01	F	9	2.380	21.42	Y
	X9110	JRT TOILET TISSUE REFILL-	01	F	12	4.760	57.12	Y
	X9213	SAHIS SCREEN SERVICE	01	F	9	2.380	21.42	Y

1460-000 -150  
 1470-000 150

SERVICE CHARGE *Rem # 12/24/24* 7.08 Y

SUBTOTAL *240-7465 linen 117.97* 441.94  
 SALES TAX 31.67  
 TOTAL USD ~~474.61~~ *480.69*

*240-362.72*  
*400-150.00*  
*600-150.00*  
 TOTAL ADJUST.

*BAW*  
*12/31/24*

TAX ADJUST.

NET TOTAL

Purchase Employee gifts or company swag through account.cintas.com and use code \$HOPLAUNCH for 10% off your \*first online order of \$150 or more. \* Promotion ends 1/31/2025.



REMIT PAYMENT TO:  
 CINTAS CORP  
 P.O. BOX 630910  
 CINCINNATI, OH 45263-0910

VIEW & PAY YOUR BILLS ONLINE:  
 WWW.CINTAS.COM/MYACCOUNT

CUSTOMER SVC/BILLING 833-290-0514  
 CINTAS FAX # 904-741-6116  
 PAYMENT INQUIRY 904-741-4525

INVOICE

SHIP TO: EAGLE LANDING GOLF CLUB  
 3989 EAGLE LANDING PKWY  
 ORANGE PARK, FL 32065-2641

INVOICE # 4216401458  
 INVOICE DATE 12/31/2024

BILL TO: EAGLE LANDING GOLF CLUB  
 3989 EAGLE LANDING PKWY  
 ORANGE PARK, FL 32065-2641

SOLD TO # 22390656  
 PAYER # 22385762  
 PAYMENT TERMS NET 10 EDM  
 SORT # 02800003369  
 CINTAS ROUTE 53 / DAY 2 / STOP 011

EMP#/LOCKS	MATERIAL	DESCRIPTION	FREQ	EXCH	QTY	UNIT PRICE	LINE TOTAL	TAX	
	X20023	SIG HRDWD WHT LRG-	01	F	12	9.520	114.24	Y	
	X2700	TERRY TOWEL - WHITE-	01	F	320	0.202	64.64	-Y	
	X2700	TERRY TOWEL - WHITE-	L 01	F	29	0.601	17.43	N	
	X27026	SIG AIR SVC	01	F	21	3.867	81.21	Y	
	X27029	SIG AIR RFL CITRUS-	04	F	27	0.000	0.00	N	
	X27097	SIG TRASHCAN DSP ALU-	01	F	24	1.190	28.56	Y	
	X2873	BIB APRON-BLACK-	01	F	60	0.441	26.46	Y	
	X2873	BIB APRON-BLACK-	L 01	F	1	9.261	9.26	N	
	X6680	DISP URINAL MAT SVC	01	F	9	2.380	21.42	Y	
	X7464	DISP URINAL MAT RFL-	04	F	9	0.000	0.00	N	
	X9110	JRT TOILET TISSUE REFILL-	01	F	12	4.760	57.12	Y	
	X9213	SANIS SCREEN SERVICE	01	F	9	2.380	21.42	Y	
	X9239	SAN SCRN CLK BRZ RFL-	04	F	9	0.000	0.00	N	
SUBTOTAL							441.94		
SERVICE CHARGE							7.03	Y	
1460-000	-212.72								
1470-000	212.72								
SUBTOTAL							449.02		
SALES TAX							31.67		
TOTAL USD							480.69		

*linen. 240-7440 - 50.00*  
*240-7440 - 75.00*  
*8460-7440 - 75.00*  
*600-7440 - 162.72*  
 TOTAL ADJUST.  
 TAX ADJUST.

NET TOTAL

Purchase Employee gifts or company swag through account.cintas.com and use code SHOPLAUNCH for 10% off your first online order of \$150 or more. \* Promotion ends 1/31/2025.

**DIRECTV**  
FOR BUSINESS

**ACCOUNT NUMBER**  
022122852

**DATE DUE**  
Immediately

**AMOUNT DUE**  
\$868.44

**INVOICE NUMBER**  
022122852X241222

To contact us call 1-800-496-4915

**Summary**

Statement Date: 12/22/24  
Page 1 of 1 for:  
SOUTH VILLAGE COMMUN  
For Service at:  
DAN STEINER  
3989 EAGLE LANDING PKWY  
ORANGE PARK, FL 32065-2641

Previous Balance	868.44
Payments	-434.22
Current Charges & Fees	398.50
Adjustments & Credits	0.00
Taxes	35.72
<b>Amount Due</b>	<b>\$868.44</b>

**PAST DUE**

**PLEASE PAY IMMEDIATELY**  
to avoid late fees or service  
interruption. If you have already  
sent your payment, thank you.

**Activity**

Start	End	Description	Amount
		Previous Balance	868.44
12/16		Payment - Thank You	-434.22
<b>Current Charges for Service Period 12/21/24 - 01/20/25</b>			
12/21	01/20	Music Choice Premium Monthly	29.99
12/21	01/20	Business XtraPack 2of2 Monthly	14.03
12/21	01/20	Business Xtra Pack 1of2 Monthly	89.24
12/21	01/20	TV Access Fee	80.00
12/21	01/20	Receiver Count 15	0.00
11/26	12/25	NFL SUNDAY TICKET 2024 5-Pay	176.00
<b>Fees</b>			
12/14		Late Fee	6.25
12/22		Regional Sports Fee	2.99
<b>Communications Service Tax</b>			<b>35.72</b>
<b>AMOUNT DUE</b>			<b>\$868.44</b>

**PAST DUE**

Please Pay Immediately to Avoid  
Late Fees or Service Interruption.  
If you have already sent your  
payment, thank you.

**Restoral Fee**

If your service is suspended due to  
non-payment, when your service is restored,  
a Restoral Fee of up to \$20 will be charged  
on your next bill.

*520-7810*  
*8*  
*AA*  
*12/31/24*

*Current chgs*  
*\$434.22*

004020 1/1



PLEASE FOLD ALONG PERFORATION, DETACH AND RETURN THIS PORTION WITH YOUR PAYMENT

**DIRECTV**  
FOR BUSINESS

**INVOICE NUMBER**  
022122852X241222

**DATE DUE**  
Immediately

**ACCOUNT NUMBER**  
022122852

**AMOUNT DUE**  
\$868.44

**PAYMENT ENCLOSED**

Note my change of address on reverse side.  
DO NOT WRITE OTHER COMMENTS ON THIS FORM

(904) 637-0848

MB 01 004020 38773 H 11 A  
SOUTH VILLAGE COMMUN  
DAN STEINER  
3989 EAGLE LANDING PKWY  
ORANGE PARK FL 32065-2641

DIRECTV  
PO BOX 5008  
CAROL STREAM IL 60197-5008



00000000000000000000022122852 1 0028 00086844 00086844 0



**DE LAGE LANDEN FINANCIAL SERVICES, INC.**  
 PO BOX 825736  
 PHILADELPHIA, PA 19182-5736

**Remittance Section**

Invoice Number: 588912768  
 Due Date: 01/01/2025  
 Due This Period: \$250.31  
 Amount Enclosed: \$ \_\_\_\_\_

025750 000004132



SOUTH VILLAGE COMMUNITY DEVELOPMENT  
 ATTN AP  
 3989 EAGLE LANDING PKWY  
 ORANGE PARK FL 32065-2641

Please make check payable to

DE LAGE LANDEN FINANCIAL SERVICES, INC.  
 PO BOX 825736  
 PHILADELPHIA, PA 19182-5736

2100005889127680000250317

Detach here. Please include the top payment coupon with your payment. Please allow 5-7 days for U.S. Postal Service delivery.



DE LAGE LANDEN FINANCIAL SERVICES,  
 INC.  
 PO BOX 825736  
 PHILADELPHIA, PA 19182-5736  
 www.leasedirect.com

Contract Number: 25489964  
 Invoice Number: 588912768  
 Account Number: 1211524  
 Site Number: 4256556  
 Invoice Date: 12/07/2024  
 Period of Performance: 12/01/2024 - 12/31/2024  
 Due This Period: \$250.31

**Important Messages**

See Reverse For Important Information

**Invoice Details**

Description	Payment Amount	Tax	Total Amount	Applied Amount	Remaining Amount Due
INSURANCE	\$19.54	\$1.46	\$21.00	\$0.00	\$21.00
PAYMENT	\$213.31	\$16.00	\$229.31	\$0.00	\$229.31
<b>Billed this Invoice</b>	<b>\$232.85</b>	<b>\$17.46</b>	<b>\$250.31</b>	<b>\$0.00</b>	<b>\$250.31</b>
<b>Balance Due Previous Invoices</b>					<b>\$0.00</b>
<b>Total Amount Due</b>					<b>\$250.31</b>

(Please see the following pages for details.)

SW-7340  
 J  
 [Signature]  
 12/23/24

### Asset Details

Contract Number	Purchase Order	Make / Model	Asset Number	Serial Number	Install Date	Cost Center	Department	Payment Amount	Tax	Total Amount
25489964		KONMIN / BHC368	25489964_1	A7PU01700432 7	02/20/2018			\$213.31	\$16.00	\$229.31
Asset Location: 3989 EAGLE LANDING PKWY ORANGE PARK CLAY FL 32065-2641 United States								<b>Asset Amount Total:</b>		<b>\$229.31</b>





**DE LAGE LANDEN FINANCIAL SERVICES, INC.**

PO BOX 825736

PHILADELPHIA, PA 19182-5736

**Remittance Section**

Invoice Number: 588944257  
Due Date: 01/06/2025  
Due This Period: \$46.83

Amount Enclosed: \$ \_\_\_\_\_

000426 000000742



SOUTH VILLAGE COMMUNITY DEVELOPMENT

ATTN AP

3989 EAGLE LANDING PKWY  
ORANGE PARK FL 32065-2641

Please make check payable to

DE LAGE LANDEN FINANCIAL SERVICES, INC.  
PO BOX 825736  
PHILADELPHIA, PA 19182-5736

2100005889442570000046831

Detach here. Please include the top payment coupon with your payment. Please allow 5-7 days for U.S. Postal Service delivery.

DE LAGE LANDEN FINANCIAL SERVICES, INC.  
PO BOX 825736  
PHILADELPHIA, PA 19182-5736  
[www.leasedirect.com](http://www.leasedirect.com)

Contract Number: 25489964  
Invoice Number: 588944257  
Account Number: 1211524  
Site Number: 4256556  
Invoice Date: 12/13/2024  
Due This Period: \$46.83

**Important Messages**

See Reverse For Important Information

**Invoice Details**

Description	Payment Amount	Tax	Total Amount	Applied Amount	Remaining Amount Due
PROPERTY TAX	\$37.57	\$2.81	\$40.38	\$0.00	\$40.38
PROPERTY TAX ADMIN FEE	\$6.00	\$0.45	\$6.45	\$0.00	\$6.45
<b>Billed this Invoice</b>	<b>\$43.57</b>	<b>\$3.26</b>	<b>\$46.83</b>	<b>\$0.00</b>	<b>\$46.83</b>
<b>Balance Due Previous Invoices</b>					<b>\$0.00</b>
<b>Total Amount Due</b>					<b>\$46.83</b>

(Please see the following pages for details.)

520-7340  
J  
AK  
12/23/24

---

**Asset Details**

Asset Number	Make / Model	Units / Serial Number	PO Number	Property Tax	Admin Fee	Tax	Total Amount
25489964_1	KONMIN / BHC368	A7PU017004327		37.57	\$6.00	\$3.28	\$46.83

Asset Location: 3989 EAGLE LANDING PKWY ORANGE PARK CLAY FL 32066-2641 United States

**Asset Amount Total: \$46.83**

---

**Property Tax Details**

Asset Number	Jurisdiction	Lien Date	Assessed Value	Rate	Property Tax
 25489964_1	Clay County	01/01/2024	\$2,565.00	1.47	\$37.57



**FLORIDA STATE GOLF ASSOCIATION**  
 12630 TELECOM DRIVE  
 TAMPA, FL 33637-0935

# Invoice

DATE	INVOICE #
12/15/2024	61588

**Attn: Accounts Payable**  
 Eagle Landing Golf Club  
 3989 Eagle Landing Parkway  
 Orange Park, FL 32065-9961

			P.O. NO.	TERMS
				Net 30
SERVICE DATE	QUANTITY	DESCRIPTION	RATE	AMOUNT
12/15/2024	22	Adult Handicaps - Added Golfers 7/1-12/14/24	9.50	209.00
12/15/2024	2	Junior Handicaps - Added Golfers 7/1-12/14/24	0.00	0.00
<p><i>100-7370</i>  <i>APL</i>  <i>12/23/24</i></p>				
<div style="border: 1px solid black; padding: 5px;"> <p>This invoice is for added golfers during the period of 7/1-12/14 and is for service through 12/31</p> </div>				
			<b>Total</b>	<b>\$209.00</b>

Please make payment to:

Florida State Golf Association  
 12630 Telecom Drive  
 Tampa, FL 33637-0935

For assistance, please call Debby at (813) 868-5811.



Harrell's LLC  
 PO Box 807  
 Lakeland, FL 33802  
 1-800-780-2774 option 3  
 Fax: 1-863-904-1545  
 E-mail: creditor@harrells.com

# INVOICE

INVOICE NUMBER	INVOICE DATE
INV01957058	10/29/2024
CUSTOMER NUMBER	TOTAL DUE
EAGLAN2	\$1,254.00

7770-400  
 12/18/24  
 77

**BILL TO:**

EAGLE LANDING GOLF CLUB  
 3989 EAGLE LANDING PKWY  
 ORANGE PARK, FL 37065  
 UNITED STATES OF AMERICA

**PAYMENT ADDRESS:**

Harrell's, LLC  
 P O Box 935358  
 Atlanta GA 31193-5358

DETACH UPPER PORTION AND RETURN WITH PAYMENT

PO NUMBER	TERMS	SALESPERSON	CUSTOMER NUMBER	INVOICE NUMBER	SHIP DATE
OLKH988126	June 6, 2025	103	EAGLAN2	INV01957058	6/30/2025
QTY	ITEM	DESCRIPTION		UNIT PRICE	AMOUNT
1	BANOLF-2.5	Banol Fungicide 2.5gal (ENVU) (Agency) (CL 3B)		\$1,254.00	\$1,254.00

*Handwritten signature and date:*  
 [Signature]  
 12/13/24



## EOP 2024

### The Tools You Need for Success.



www.harrells.com | 800.262.8007  
Employee Only

**TERMS AND CONDITIONS**

I understand that Harrell's General Terms and Conditions of Sale, as they may be amended from time-to-time, (the "Terms and Conditions") are incorporated herein by reference as if fully set forth herein. The Terms and Conditions can be located on Harrell's website (www.harrells.com). In the event of a direct conflict between a specific term of this invoice and the Terms and Conditions, the specific term of this invoice shall prevail.

**SHIPPING ADDRESS**

Ship-to Acct Number: EAGLAN2  
 EAGLE LANDING GOLF CLUB  
 3989 OAK LANDING PLANTATION  
 Jon Roe  
 ORANGE PARK, FL 32065  
 UNITED STATES OF AMERICA

SUBTOTAL	\$1,254.00
TAX/STATE FEES	\$0.00
<b>TOTAL</b>	<b>\$1,254.00</b>



Harrell's LLC  
 PO Box 807  
 Lakeland, FL 33802  
 1-800-780-2774 option 3  
 Fax: 1-863-904-1545  
 E-mail: [creditar@harrells.com](mailto:creditar@harrells.com)

# INVOICE

INVOICE NUMBER	INVOICE DATE
INV01957062	10/29/2024
CUSTOMER NUMBER	TOTAL DUE
EAGLAN2	\$758.00

7770-400  
 12/18/24  
 77

**BILL TO:**

EAGLE LANDING GOLF CLUB  
 3989 EAGLE LANDING PKWY  
 ORANGE PARK, FL 37065  
 UNITED STATES OF AMERICA

**PAYMENT ADDRESS:**

Harrell's, LLC  
 P O Box 935358  
 Atlanta GA 31193-5358

DETACH UPPER PORTION AND RETURN WITH PAYMENT

PO NUMBER	TERMS	SALESPERSON	CUSTOMER NUMBER	INVOICE NUMBER	SHIP DATE
OLKH988169	June 6, 2025	103	EAGLAN2	INV01957062	6/30/2025
QTY	ITEM	DESCRIPTION		UNIT PRICE	AMOUNT
1	REVOLV	Revolver 87 OZ (CL 2) (HA) (Agency) Not regulated by the DOT for ground transportation. If shipped otherwise, consult MSDS/SDS.		\$758.00	\$758.00
Bayer					
All products listed on this invoice belong to Environmental Science U.S. Inc. and are being handled by us on a consignment basis. The purchase price of these products are set by Environmental Science U.S. Inc. and are to be paid to Harrell's, LLC. as the					

*[Handwritten signature]*  
 12/18/24



## EOP 2024

### The Tools You Need for Success.



**TERMS AND CONDITIONS**

I understand that Harrell's General Terms and Conditions of Sale, as they may be amended from time-to-time, (the "Terms and Conditions") are incorporated herein by reference as if fully set forth herein. The Terms and Conditions can be located on Harrell's website ([www.harrells.com](http://www.harrells.com)). In the event of a direct conflict between a specific term of this Invoice and the Terms and Conditions, the specific term of this Invoice shall prevail.

**SHIPPING ADDRESS**

Ship-to Acct Number: EAGLAN2  
 EAGLE LANDING GOLF CLUB  
 3989 OAK LANDING PLANTATION  
 Jon Roe  
 ORANGE PARK, FL 32065  
 UNITED STATES OF AMERICA

SUBTOTAL	\$758.00
TAX/STATE FEES	\$0.00
<b>TOTAL</b>	<b>\$758.00</b>



ODP Business Solutions, LLC  
 PO BOX 7241  
 SIOUX FALLS SD  
 57117-7241

ORIGINAL INVOICE

10000

THANKS FOR YOUR ORDER

IF YOU HAVE ANY QUESTIONS  
 OR PROBLEMS, JUST CALL US

FOR CUSTOMER SERVICE ORDER: (888) 263-3423  
 FOR ACCOUNT: (800) 721-6592

FEDERAL ID: 86-2161688

INVOICE NUMBER	AMOUNT DUE	PAGE NUMBER
400354429001	48.90	Page 1 of 1
INVOICE DATE	TERMS	PAYMENT DUE
09-DEC-24	Net 30	12-JAN-25

BILL TO:

ATTN: ACCTS PAYABLE  
 EAGLE LANDING GOLF COURSE  
 3989 EAGLE LANDING PKWY  
 ORANGE PARK FL 32065-2641

002872-000359

SHIP TO:

EAGLE LANDING GOLF COURSE  
 3989 EAGLE LANDING PKWY  
 ORANGE PARK FL 32065-2641



ACCOUNT NUMBER 15779562	PURCHASE ORDER	SHIP TO ID 3989EAGLELANDINGPKWY	ORDER NUMBER 400354429001	ORDER DATE 05-DEC-24	SHIPPED DATE 09-DEC-24		
BILLING ID 21782146	ACCOUNT MANAGER RELEASE	ORDERED BY JOE HALIFKO	DESKTOP	COST CENTER			
CATALOG ITEM #/ MANUF CODE	DESCRIPTION/ CUSTOMER ITEM #	U/M	QTY ORD	QTY SHP	QTY B/O	UNIT PRICE	EXTENDED PRICE
619244 COMORG-BLK	ORGANIZER,CNDMNT,COF 619244	EA	1	1	0	45.490	45.49

*520-7450*  
*APC*  
*12/31/24*

002872-000359

SUB-TOTAL	45.49
DELIVERY	0.00
SALES TAX	3.41
TOTAL	48.90

All amounts are based on USD currency

To return supplies, please repack in original box and insert our packing list, or copy of this invoice. Please note problem so we may issue credit or replacement, whichever you prefer. Please do not ship collect. Please do not return furniture or machines until you call us first for instructions. Shortage or damage must be reported within 5 days after delivery.

DETACH HERE

CUSTOMER NAME	BILLING ID	INVOICE NUMBER	INVOICE DATE	INVOICE AMOUNT	AMOUNT ENCLOSED
EAGLE LANDING GOLF COURSE	21782146	400354429001	09-DEC-24	48.90	

FL0 217821461 4003544290018 00000004890 1 0

Please  
 Send Your  
 Check to:

ODP Business Solutions, LLC  
 PO Box 1413  
 Charlotte NC 28201-1413

Please return this stub with your payment to  
 ensure prompt credit to your account.

Please DO NOT staple or fold. Thank You.



ODP Business Solutions, LLC  
 PO BOX 7241  
 SIOUX FALLS SD  
 57117-7241

ORIGINAL INVOICE

10000

THANKS FOR YOUR ORDER

IF YOU HAVE ANY QUESTIONS  
 OR PROBLEMS, JUST CALL US  
 FOR CUSTOMER SERVICE ORDER: (888) 263-3423  
 FOR ACCOUNT: (800) 721-6592

FEDERAL ID: 86-2161688

INVOICE NUMBER	AMOUNT DUE	PAGE NUMBER
400353933001	156.84	Page 1 of 1
INVOICE DATE	TERMS	PAYMENT DUE
10-DEC-24	Net 30	12-JAN-25

BILL TO:

ATTN: ACCTS PAYABLE  
 EAGLE LANDING GOLF COURSE  
 3989 EAGLE LANDING PKWY  
 ORANGE PARK FL 32065-2641

SHIP TO:

EAGLE LANDING GOLF COURSE  
 3989 EAGLE LANDING PKWY  
 ORANGE PARK FL 32065-2641



CATALOG ITEM #/ MANUF CODE	DESCRIPTION/ CUSTOMER ITEM #	U/M	QTY ORD	QTY SHP	QTY B/O	UNIT PRICE	EXTENDED PRICE
6998791 3YP30AN#140	INK,HP,67 CLR/67XL BLK,2PK 6998791	EA	1	1	0	52.290	52.29
3321139 3YM57AN#140	INK,HP,67XL,BLACK 3321139	EA	1	1	0	30.990	30.99
1780964 3YM58AN#140	INK,HP,67XL,TRI-COLOR 1780964	EA	1	1	0	30.990	30.99
541545 888400	Forever Stamp - Book of 20 541545	EA	1	1	0	14.600	14.60
357914 PRCSNG FEE	Postage Processing Fee 0357914	EA	1	1	0	1.000	1.00
952733 31256	PEN,RT,GEL,G2,1.0MM,DZ,BLA 952733	DZ	1	1	0	17.130	17.13

520-7450

ODP Business, Com

BSD - Tax exemption

SUB-TOTAL	147.00
DELIVERY	0.00
SALES TAX	9.84
TOTAL	156.84

All amounts are based on USD currency

To return supplies, please repack in original box and insert our packing list, or copy of this invoice. Please note problem so we may issue credit or replacement, whichever you prefer. Please do not ship collect. Please do not return furniture or machines until you call us first for instructions. Shortage or damage must be reported within 5 days after delivery.

DETACH HERE

CUSTOMER NAME	BILLING ID	INVOICE NUMBER	INVOICE DATE	INVOICE AMOUNT	AMOUNT ENCLOSED
EAGLE LANDING GOLF COURSE	21782146	400353933001	10-DEC-24	156.84	

FLO 217821461 4003539330019 00000015684 1 6

Please  
 Send Your  
 Check to:

ODP Business Solutions, LLC  
 PO Box 1413  
 Charlotte NC 28201-1413

Please return this stub with your payment to  
 ensure prompt credit to your account.

Please DO NOT staple or fold. Thank You.





**Invoice**

Paul Murray Oil, Inc.  
2900 Phoenix Ave

Jacksonville, FL 32206 USA  
Phone: (904)353-1411

Remit To: 2900 Phoenix Ave Jacksonville, FL 32206

Account Number: 18040030  
Invoice Number: RO160734  
Invoice Date: 12/18/2024 11:12:49 AM  
Delivery Date: 12/18/2024 11:12:49 AM

*740 - 400*  
*12/20/24*  
*73*

Amount Due: \$755.46
Due Date: 01/17/2025

Eagle Landing CC  
3989 Eagle Landing Pkwy  
Orange Park, FL 32065

Shipping Address:  
Eagle Landing CC  
3989 Eagle Landing Pkwy  
Orange Park, FL 32065

HM	DOT- Name, Class, ID, Group	Product	Product Description	Delivered Quantity	Unit Price	Extended Price
	Carrier: PMO		Vehicle: none		Salesperson: none	
	Order Number: RO160734		Purchase Order Number: none		BOL Number: RO160734	
	231/Bulk		Dyed Ultra Low Sulfur Diesel	118.1000	\$2.92340	\$345.25
					Tax:	\$29.40
					Total This Item:	\$374.65
					NET 30 Terms:	\$0.00
CRITICAL DESCRIPTION: DYED ULTRA LOW SULFUR FUEL; NON-TAXABLE USE ONLY. PENALTY FOR TAXABLE USE. MAX SULFUR OF 15PPM, MAX CLOUD OF 15, MIN CETANE OF 40 & MAY CONTAIN UP TO 5% BIODIESEL						
	Carrier: PMO		Vehicle: none		Salesperson: none	
	Order Number: RO160734		Purchase Order Number: none		BOL Number: RO160734	
	065/Bulk		Regular Gasonline/Bulk	128.3000	\$2.39250	\$306.96
					Tax:	\$73.85
					Total This Item:	\$380.81
					NET 30 Terms:	\$0.00

*APC*  
*12/23/24*

Invoice Taxes	Certificate Number	Amount Due	Exempt
Federal Excise Tax - LUST		\$0.25	No
Federal Gas Excise Tax		\$23.48	No
Fed Envir Fee - 10% Ethanol		\$0.25	No
Fed Envir Fee - Diesel		\$0.25	No
Florida Fuel Tax		\$27.10	No
Florida Pollution Fee		\$5.11	No
Florida Local Option Tax		\$7.70	No
Florida S.C.E.T.S.		\$12.06	No
Florida Sales Tax		\$20.88	No
Clay Co SUR Tax		\$5.22	No
Fed Superfund Recovery - Diesel		\$0.48	No
Fed Superfund Recovery - 10% Ethanol		\$0.47	No

No terms discount available for this invoice.

Products Total:	\$652.21
Shipping / Freight Total:	\$0.00
Header Freight Surcharge:	\$0.00
Tax Total:	\$103.25
Invoice Total:	\$755.46
Discount Total:	\$0.00
Net Invoice Total:	\$755.46
<b>Total Due:</b>	<b>\$755.46</b>



**INVOICE**

400-7630  
12/18/24  
*[Signature]*

**Invoice**  
683014  
**Date**  
12/16/24  
**Time**  
8:54:15

2510 N.W. 16th Lane  
Pompano Beach, FL 33064-1505 USA

Tel: (954) 974-1960 Fax: (954) 968-3398  
E-Mail: [accounting@precisionusa.com](mailto:accounting@precisionusa.com)  
[www.precisionusa.com](http://www.precisionusa.com)

Ordered By / PO No: 16240

**Sold To Acct. No.** 16240  
EAGLE LANDING GOLF CLUB  
ATTN: ACCOUNTS PAYABLE DEPT  
3989 EAGLE LANDING PKWY  
ORANGE PARK FL 32065-2641

**Ship To Acct. No.** 01  
EAGLE LANDING GOLF CLUB  
ATTN: GOLF MAINTENANCE DEPT  
890 OAKLEAF PLANTATION PKWY  
ORANGE PARK FL 32065-

**Ship Via** UPS Ground/Dropship  
**Pay Type** Accounts Receivables

**Terms** Net 30 Days

Order No:	Order Date:	Entered By:	Sales Rep. No/Name	Ref No:	Page:
55170/00	12/09/24	ANNIEH	1 House Account		1 of 1

Order	Ship	B/O	LC	Item Number/Description	Reg Price	Unit Price	Discount	Total
2	2		096 27-6994	Trimmer Head Pro Bump & Feed	68.50	50.95	Most Applications *NO Kawasaki*	101.90
2	2		150 99969-6082C	Oil 2 Cycle LOW SMOKE 1 Gal Mix	138.28	79.95	Case of 48	159.90
				Replaces LU PLS1-48				
8	8		045 5189761	Tire 18x8.50-8 4PLY E	71.56	71.56	Carlisle Fairway Pro Tread	572.48
				Replaces CR 5192721				
12	12		096 24-9872	Spark Plug NGK BKR5E	6.08	6.08	Minimum Order 4 Pieces	72.96
8	8		096 24-7423	Spark Plug Champion RC12YC	3.95	3.95	Order in Multiples of 4	31.60
1	1		486 CATALOG	Underhill Catalog 2024	.00	.00		.00
1	1		280 TOOLPRO	ToolWeb Catalog	5.95	.00	Oct 2024 - Dec 2024	.00
1		1	107 2025	Master Catalog 2025 PRECISION	10.00	.00	45th Anniversary Edition	.00

Shipping & Handling

119.12

If sales tax not charged, please pay use tax to your state.

*[Handwritten signature]*

Note:

**SUBTOTAL:** 1,057.96  
**% Base Tax**

**TOTAL:** 1,057.96

**PLEASE PAY FROM THIS INVOICE**  
Make Checks Payable to: Precision Small Engine Co., Inc.

**Due Date:** 01/15/25



4613 Phillips Hwy 208B Jacksonville, FL 32207  
(904)661-7590

### Important Messages



 Stay informed about the latest scams targeting consumers, get specific tips to recognize scammers and important guidelines that will help you act accordingly.

[Go to SharpEnergy.com > Propane > Safety & Security > Scams & Awareness](#)

**! Safety Tip !**

If you are a will-call customer, remember to refill your propane tank before it reaches 25% capacity. If you are an automatic customer, your propane delivery will be scheduled as usual.

**JOIN OUR ONLINE CUSTOMER PORTAL**

Payment Options      Request Service Online  
24/7 Account Access      Order Propane

[myaccountsharpenergy.com](http://myaccountsharpenergy.com)

### Invoice Information

Customer Name: SOUTH VILLAGE, CDD  
 Account Number: 2036053  
 Current Balance: \$711.55  
 Invoice Date: 12/23/24  
 Due Date: Upon Receipt  
 Amount Due: \$2,988.52

Finance charge of 1.5% per month assessed on balances over 30 days  
Sharpgas, Inc. Fed# 51-0255314

### Summary of Transactions

DATE	REF #	DESCRIPTION	AMOUNT
		PREVIOUS BALANCE	\$2,276.97
12/19/24	91654	BULK PROPANE JACKSONVILLE 233.3GALS@\$2.9657	\$691.90
12/19/24	91654	COUNTY UTILITY TAX /3989 EAGLE LANDING PARKWAY Y//ORANGE PARK FL 32065	\$19.65

### Summary of Amount Due

Previous Balance	\$2,276.97
Current Transactions	\$711.55
<b>Amount Due:</b>	<b>\$2,988.52</b>

**WARNING:** (1) Over time, propane could experience odor fade. For your added safety, we recommend you consider purchasing and installing a propane detector. These can be found at most retail hardware stores. (2) Please be aware that there are unaffiliated bill pay websites that may represent themselves as Sharp Energy. To securely pay your bill online, please visit our website at SharpEnergy.com.

Page 1 of 2      Please detach and return this portion with your payment. Please do not staple, clip or attach check to the remittance payment coupon.      Please bring entire invoice when paying in person.

4613 Phillips Hwy 208B  
Jacksonville, FL 32207  
Return Service Requested

**\*\*INVOICE\*\***

SOUTH VILLAGE, CDD  
3989 EAGLE LANDING PKWY  
ATTN: JAMES HAHN  
ORANGE PARK, FL 32065

240-777-0000  
12/31/24

### Remittance Section

Account Number: 2036053  
 Invoice Date: 12/23/24  
 Due Date: Upon Receipt  
 Amount Due: \$2,988.52  
 Amount Paid: \$ \_\_\_\_\_

Please do not staple, clip or attach check to the remittance payment coupon. Make check payable to: Sharp Energy, Inc. Write your account number on your check. Save a stamp! Pay online at www.SharpEnergy.com Thank you!

SHARP ENERGY JACKSONVILLE  
 PO BOX 829981  
 PHILADELPHIA, PA 19182-9981





EAGLE LANDING GOLF CLUB  
3989 EAGLE LANDING PKWY  
ORANGE PARK FL 32065-2641



SYSCO JACKSONVILLE, INC.  
1501 LEWIS INDUSTRIAL DRIVE  
JACKSONVILLE, FL 32254  
1-800-797-2627 (1-800 SYSCO CS)

904-637-0648

EAGLE LANDING GOLF CLUB  
3989 EAGLE LANDING PKWY  
ORANGE PARK FL 32065 -2641

CUSTOMER'S ORIGINAL INVOICE CONFIDENTIAL PROPERTY OF SYSCO

DELV. DATE	CUSTOMER	INVOICE NUMBER	PAGE
12/14/24	784966	583004318	7 2
TRUCK STOP	624 / 002		
ROUTE	PURCHASE ORDER		
6637	TERMS - FAST DUE BALANCES ARE SUBJECT TO SERVICE CHARGE		
Net 30			
MANIFEST# 1274346 NORMAL DELIVERY			
MA: TVADC SCARLETT BAYLESS			

DRIVER:

QTY	PACK	SIZE	ITEM DESCRIPTION	ITEM CODE	UNIT PRICE	UNIT TAX AMOUNT	EXTENDED PRICE	INVOICE ADJUSTMENTS
GROUP TOTAL****								237.30
D	1 CS	1509X9X3	SYS CLS CONTAINER FOAM HNG 1C D YTD199S10000	7551334	21.02		21.02	
D	1 CS	2025 CT	DART CUP FOAM TALL 20 OZ 20J16	4088886	27.56		27.56	
D	1 CS	10100CT	DART LID PLAS STRAW SLOT 12-24OZ 16SL	4096327	18.90		18.90	
D	1 CS	10060 GAL	SYS REL LINER REPRO 38X58 1.5 ML X7658AKSX01	1763846	41.77		41.77	
GROUP TOTAL****								109.25
***PRODUCE***								
C	1 CS	112 CT	IMPFRSH AVOCADO HASS FRESH	1185511	29.60		29.60	
C	2S	ONLY5 LB	IMPFRSH LEMON FRESH 10889356163013	7289542	11.37		22.74	
C	1 CS	148 CT	PACKER LIME FRESH	1079425	16.58		16.58	
C	1S	ONLY10 LB	IMPFRSH ONION YELLOW JUMBO FRESH SACK	7201992	9.07		9.07	
C	1S	ONLY5 LB	IMPFRSH ORANGE BAGGED FRESH 10889356163020	7289526	9.56		9.56	
C	1S	ONLY16 OZ	DRISCOL STRAWBERRY FRESH DRISCOLL	7582505	7.22		7.22	
GROUP TOTAL****								94.77
***DISPENSER BEVERAGE***								
D	1 CS	12.5GAL	COCACOL SYRUP PIBB XTRA 14450298	9181512	54.95		54.95	1460-000 -35.56 1470-000 35.56
D	1 CS	15 GAL	SPRITE SYRUP SPRITE 5X1 BIB 09560010	4090395	105.40		105.40	
GROUP TOTAL****								160.35
MISC CHARGES								6.19
ALLOWANCE FOR DROP SIZE								8.00
CHGS FOR FUEL SURCHARGE								
ORDER SUMMARY : 2728318 2729967 2729543								

*[Handwritten signature]*  
12/14/24

000  
240-1340 = 634.31  
200-5500 = 35.56  
500-7450 = 109.25  
Total = 779.12

CASES	SPLIT TOT. PCS	CUBE	GROSS WT.	OPEN: 7:00 AM	CLOSE: 5:00 PM	REMIT TO	
8	5	13	13.3	168		SYSCO JACKSONVILLE 1501 LEWIS INDUSTRIAL DR JACKSONVILLE, FL 32254	SUB TOTAL 779.12
19	8	27	24.6	461			TAX TOTAL INVOICE TOTAL 779.12
DRIVER'S SIGN	NO. PCS DELVD.	CUST. SIGNED INVOICE EVIDENCE OF ALL ITEMS SIGN <b>X</b>	NO. PCS REC.	PAYABLE ON OR BEFORE 1/13/25		LAST PAGE	

IMPORTANT FACA PROVISION: THE PERISHABLE AGRICULTURAL COMMODITIES LISTED ON THIS INVOICE ARE SUBJECT TO THE STATUTORY TRUST ESTABLISHED BY SECTION 5 (C) OF THE PERISHABLE AGRICULTURAL COMMODITIES ACT 1930 (U.S.C. 499E(C)). THE SELLER OF THIS COMMODITY WARRANTS A TRUE CLAIM OVER THESE COMMODITIES. ALL INVENTORIES OF FOOD OR OTHER PRODUCTS DERIVED FROM THESE COMMODITIES AND ANY RECEIVABLES OR PROCEEDS FROM THE SALE OF THESE COMMODITIES UNTIL FULL PAYMENT IS RECEIVED. FURTHER, YOU AGREE WITH RESPECT TO ANY DISPUTE ARISING OUT OF YOUR RECEIPT OF THESE PRODUCTS/SERVICES: YOU ARE GIVING UP YOUR RIGHT TO SERVE IN ANY REPRESENTATIVE CAPACITY, OR TO PARTICIPATE AS A MEMBER OF A CLASS OF CLAIMANTS, IN ANY LAWSUIT INVOLVING ANY SUCH DISPUTE.

EQUAL OPPORTUNITY AND AFFIRMATIVE ACTION CLAUSES OF 41 CFR 60-1.4, 60-250.4 AND 60-714.4 ARE INCORPORATED HEREIN BY REFERENCE.





EAGLE LANDING GOLF CLUB  
3989 EAGLE LANDING PKWY  
ORANGE PARK FL 32065-2641



SYSCO JACKSONVILLE, INC.  
1501 LEWIS INDUSTRIAL DRIVE  
JACKSONVILLE, FL 32254  
1-800-797-2627 (1-800 SYSCO CS)

904-637-0648

EAGLE LANDING GOLF CLUB  
3989 EAGLE LANDING PKWY  
ORANGE PARK FL 32065 -2641

CUSTOMER'S ORIGINAL INVOICE CONFIDENTIAL PROPERTY OF SYSCO

DELV. DATE	CUSTOMER	INVOICE NUMBER	PAGE
12/14/24	784966	583004318	7 1
TRUCK STOP	PURCHASE ORDER		
624/002	TERMS - PAST DUE BALANCES ARE SUBJECT TO SERVICE CHARGE		
ROUTE	Net 30		
6637	MANIFEST# 1274346 NORMAL DELIVERY		
	MA: TVADC SCARLETT BAYLESS		

DRIVER:

QTY	PACK	SIZE	ITEM DESCRIPTION	ITEM CODE	UNIT PRICE	UNIT TAX AMOUNT	EXTENDED PRICE	INVOICE ADJUSTMENTS
FOOD SAFETY REMINDER: NOTHING IS MORE IMPORTANT TO SYSCO THAN DELIVERING SAFE PRODUCTS. PLEASE VERIFY EACH ORDER UPON RECEIPT BECAUSE COOLER ITEMS CANNOT BE RETURNED LATER.								
SALTNATER FISH LIC WD-4511 FRESHWATER FISH LIC FWD-303 SHELLFISH CERT NUMBER 182 SS								
***DAIRY***								
C	1 CS	45 LB	DAISY CREAM SOUR PURE GR A	IDA5	1186253	30.97	30.97	
C	1 CS	41 GAL	WHLFCLS MILK WHL GALLON		4676306	23.93	23.93	
GROUP TOTAL****							54.90	
***MEATS***								
F	1 CS	325 OZ	CAB BEEF STEAK PHILLY CAB BR 10000001650		9789785	81.85	81.85	
GROUP TOTAL****							81.85	
***FROZEN***								
F	1 CS	722.4 OZ	BAV BAK PRETZEL BAVARIAN STK	3295	6849145	38.89	38.89	
GROUP TOTAL****							38.89	
***CANNED & DRY***								
D	1 CS	160 CT	LAYS CHIP VARIETY FRITO LA 00028400318310	6586721	35.56		35.56	
C	1S	ONLY1 GAL	KENS DRESSING BALSAMIC VINEGARETTE KE0955	7872328	16.98		16.98	
D	1 CS	1232 OZ	OCNSPRY JUICE CRNBRY BTL BAR MIXER 25900	5099122	24.47		24.47	
C	1 CS	859 OZ	TROPANA JUICE ORANGE PURE PRE 10048500201029	8410563	32.72		32.72	
D	1 CS	1211.5OZ	HELLMAN MAYONNAISE SQUEEZE BT 00000084137049	3420587	53.75		53.75	
D	1S	ONLY1 GAL	CASACLS PEPPER JALAPENO SLICES 12730720211	8426330	12.17		12.17	
D	1S	ONLY23 OZ	IMP/MCC SEASONING BLACKENED REDFIS 901293725	4029761	11.03		11.03	
D	2 CS	4016.9OZ	NIAGARA WATER BOTTLED SPRING	9901031	13.73		27.46	
D	1 CS	612 CT	TAC MEX WRAP TORTILLA GRCL HERB 12 195210	8031852	23.16		23.16	

CASES	SPLIT	TOT. PCS	CUBE	GROSS WT.	OPEN: 7:00 AM	CLOSE: 5:00 PM	REMIT TO
11	3	14	11.3	293			SYSCO JACKSONVILLE 1501 LEWIS INDUSTRIAL JACKSONVILLE, FL 32254
							TOTAL 412.94
DRIVER'S SIGN				NO. PCS DELVD.	CUST. SIGNED INVOICE EVIDENCE OF ALL ITEMS SIGN	NO. PCS REC.	TAX TOTAL
					X		INVOICE TOTAL

IMPORTANT FACT PROVISION: THE PERISHABLE AGRICULTURAL COMMODITIES LISTED ON THIS INVOICE ARE SUBJECT TO THE STATUTORY TRUST ESTABLISHED BY SECTION 5 (C) OF THE PERISHABLE AGRICULTURAL COMMODITIES ACT 1930 (U.S.C. 495E(C)). THE SELLER OF THIS COMMODITY RETAINS A TRUST CLAIM OVER THESE COMMODITIES, ALL INVENTORIES OF FOOD OR OTHER PRODUCTS DERIVED FROM THESE COMMODITIES, AND ANY RECEIPTS OR PROCEEDS FROM THE SALE OF THESE COMMODITIES UNTIL FULL PAYMENT IS RECEIVED. FURTHER, YOU AGREE WITH RESPECT TO ANY DISPUTE ARISING OUT OF YOUR RECEIPT OF THESE PRODUCTS/SERVICES: YOU ARE GIVING UP YOUR RIGHT TO SERVE IN ANY REPRESENTATIVE CAPACITY, OR TO PARTICIPATE AS A MEMBER OF A CLASS OF CLAIMANTS, IN ANY LAWSUIT INVOLVING ANY SUCH DISPUTE.

PAYABLE ON OR BEFORE

CONT. ON PAGE 2

EQUAL OPPORTUNITY AND AFFIRMATIVE ACTION CLAUSES OF 41 CFR 60-1.4, 60-250.4 AND 60-724.4 ARE INCORPORATED HEREIN BY REFERENCE



EAGLE LANDING GOLF CLUB  
3989 EAGLE LANDING PKWY  
ORANGE PARK FL 32065-2641



SYSCO JACKSONVILLE, INC.  
1501 LEWIS INDUSTRIAL DRIVE  
JACKSONVILLE, FL 32254  
1-800-797-2627 (1-800 SYSCO CS)

904-637-0648

EAGLE LANDING GOLF CLUB  
3989 EAGLE LANDING PKWY  
ORANGE PARK FL 32065 -2641

CUSTOMER'S ORIGINAL INVOICE CONFIDENTIAL PROPERTY OF SYSCO

DELV. DATE	CUSTOMER	INVOICE NUMBER	PAGE
12/18/24	784966	583008313	4 3
TRUCK STOP	349/013		
ROUTE	PURCHASE ORDER		
3612	TERMS -PAST DUE BALANCES ARE SUBJECT TO SERVICE CHARGE		
Net 30			
MANIFEST# 1274796 NORMAL DELIVERY			
MA: TVADC SCARLETT BAYLESS			

DRIVER: TEMPLETON

QTY	PACK	SIZE	ITEM DESCRIPTION	ITEM CODE	UNIT PRICE	UNIT TAX AMOUNT	EXTENDED PRICE	INVOICE ADJUSTMENTS
2	CS	13 CT	IMPFRSH PINEAPPLE FRESH	5198791	19.21		38.42	
1	CS	15 LB	IMPFRSH SQUASH YELLOW MED FRSH	6687552	11.58		11.58	
3	S ONLY	16 OZ	DRISCOL STRAWBERRY FRESH DRISCOLL	7582505	7.22		21.66	
GROUP TOTAL****							191.83	
***DISPENSER BEVERAGE***								
1	CS	15 GAL	COCACOL SYRUP COKE CLASSIC SX1 BIB 04250010	4090593	105.40		105.40	
GROUP TOTAL****							105.40	
MISC CHARGES							9.77	*
ALLOWANCE FOR DROP SIZE							8.00	
CHGS FOR FUEL SURCHARGE								
ORDER SUMMARY : 2732439								
							1460-000	-46.42
							1470-000	46.42

*[Handwritten signature]*  
1/4/25

844.50  
240-1340 = ~~240.00~~  
200-5500 = 46.42  
500-7450 = 177.08  
Total = ~~1111.00~~  
1068.60

CASES	SPLIT	TOT. PCS	CUBE	GROSS WT.	OPEN: 7:00 AM	CLOSE: 5:00 PM	REMIT TO	SUB TOTAL
4	3	7	2.8	86			SYSCO JACKSONVILLE 1501 LEWIS INDUSTRIAL DR JACKSONVILLE, FL 32254	1079.69
29	17	46	31.1	662	NO. PCS DELVD.	CUST. SIGNED INVOICE EVIDENCE OF ALL ITEMS SIGN <b>X</b>	NO. PCS REC.	TAX TOTAL INVOICE TOTAL
							PAYABLE ON OR BEFORE	1079.69

IMPORTANT FACTA PROVISION: THE PERISHABLE AGRICULTURAL COMMODITIES LISTED ON THIS INVOICE ARE SUBJECT TO THE STATUTORY TRUST AUTHORIZED BY SECTION 5 (C) OF THE PERISHABLE AGRICULTURAL COMMODITIES ACT 1930 (U.S.C. 498(C)). THE SELLER OF THIS COMMODITY RECEIVES A TRUST CLAIM OVER THESE COMMODITIES, ALL INVENTORIES OF FOOD OR OTHER PRODUCTS DERIVED FROM THESE COMMODITIES AND ANY RECEIVABLES OR PROCEEDS FROM THE SALE OF THESE COMMODITIES UNTIL FULL PAYMENT IS RECEIVED. FURTHER, YOU AGREE WITH RESPECT TO ANY DISPUTE ARISING OUT OF YOUR RECEIPT OF THESE PRODUCTS/SERVICES: YOU ARE GIVING YOUR RIGHT TO SERVE IN ANY REPRESENTATIVE CAPACITY OR TO PARTICIPATE AS A MEMBER OF A CLASS OF CLAIMANTS IN ANY LITIGATION INVOLVING ANY SUCH DISPUTE.

1/17/25  
LAST PAGE - 11.09  
11.09

EQUAL OPPORTUNITY AND AFFIRMATIVE ACTION CLAUSES OF 41 CFR 60-1.4, 60-250.4 AND 60-716.4 ARE INCORPORATED HEREIN BY REFERENCE



CUSTOMER'S ORIGINAL INVOICE CONFIDENTIAL PROPERTY OF SYSCO

EAGLE LANDING GOLF CLUB  
3989 EAGLE LANDING PKWY  
ORANGE PARK FL 32065-2641



SYSCO JACKSONVILLE, INC.  
1501 LEWIS INDUSTRIAL DRIVE  
JACKSONVILLE, FL 32254  
1-800-797-2627 (1-800 SYSCO CS

904-637-0648

EAGLE LANDING GOLF CLUB  
3989 EAGLE LANDING PKWY  
ORANGE PARK FL 32065 -2641

DELV. DATE	CUSTOMER	INVOICE NUMBER	PAGE	
12/18/24	784966	583008313	4	1
TRUCK STOP	349/013			
ROUTE	PURCHASE ORDER			
3612	TERMS -PAST DUE BALANCES ARE SUBJECT TO SERVICE CHARGE			
Net 30				
MANIFEST# 1274796 NORMAL DELIVERY				
MA: TVADC SCARLETT BAYLESS				

DRIVER: TEMPLETON

QTY	PACK	SIZE	ITEM DESCRIPTION	ITEM CODE	UNIT PRICE	UNIT TAX ADJUST	EXTENDED PRICE	TOT	INVOICE ADJUSTMENTS
<p>FOOD SAFETY REMINDER: NOTHING IS MORE IMPORTANT TO SYSCO THAN DELIVERING SAFE PRODUCTS. PLEASE VERIFY EACH ORDER UPON RECEIPT BECAUSE COOLER ITEMS CANNOT BE RETURNED LATER.</p> <p>SALTWATER FISH LIC WD-4511 FRESHWATER FISH LIC FWD-303 SHELLFISH CERT NUMBER 182 SS</p>									
***DAIRY***									
C	1 CS	ONLY 5 LB	SYS IMP CHEESE BLUE CRUMBLES 1009125	0671677	18.43		18.43		
C	1 CS	45 LB	CASAIMP CHEESE CHEDDAR JACK FNCY SHRE 2905C4	2406189	56.05		56.05		
C	1 CS	81.5 LB	BERLIMP CHEESE MONT PPR JK SLI INT .7 170751	3554553	40.80		40.80		
C	1 CS	45 LB	GLC CHEESE MOZZ LMPS FEA SHRD 15034	7256859	54.56		54.56		
C	1 CS	81.5 LB	BERLIMP CHEESE PROV NONSMK SLI .75 170754	3546386	42.41		42.41		
C	1 CS	3849 ML	INT DEL CREAMER REAL DAIRY HALF & HAL 136469	0358608	17.98		17.98		
GROUP TOTAL****							230.23		
***MEATS***									
F	1 CS	962 OZ	SYS IMP SAUSAGE PATTY W/H WIDE RAW MLD 19741	3756236	33.32		33.32		
GROUP TOTAL****							33.32		
***FROZEN***									
F	1 CS	722 OZ	BURRY MUFFIN ENGLISH PLAIN FKSPLT 30001	3523463	21.98		21.98		
F	1 CS	82LB	TANTLZR ONION RING BRD GOURM 5/8IN 30410	0916387	57.07		57.07		
F	1 CS	62.5 LB	MCCAIN POTATO FRY SWEET 5/16 MCF03731	3700499	31.08		31.08		
GROUP TOTAL****							110.13		
***CANNED & DRY***									
D	1 CS	2420 OZ	GATRADE DRINK FROST RIPTIDE R 10052000324881	8399529	29.84		29.84		
C	2 CS	859 OZ	TROPONA JUICE ORANGE PURE PRE 10048500201029	8410563	32.72		65.44		
D	1 S	ONLY 1 GAL	SYS IMP OLIVE GREEN QUEEN PIT 100/120 22919	7097100	44.56		44.56		

CASES	SPLIT	TOT. PCS	CUBE	GROSS WT.	OPEN: 7:00 AM	CLOSE: 5:00 PM	REMIT TO
12	2	14	9.4	254			SYSCO JACKSONVILLE 1501 LEWIS INDUSTRIAL DR JACKSONVILLE, FL 32254
							NET TOTAL 513.52

DRIVER'S SIGN	NO. PCS DELVD.	CUST. SIGNED INVOICE EVIDENCE OF ALL ITEMS SIGN	NO. PCS REC.	TAX TOTAL
		X		INVOICE TOTAL

IMPORTANT FACT PROVISION: THE PERISHABLE AGRICULTURAL COMMODITIES LISTED ON THIS INVOICE ARE SUBJECT TO THE STATUTORY TROST... PAYABLE ON OR BEFORE CONT. ON PAGE 2

LEGAL OPORUNITY AND AFFIRMATIVE ACTION CLAUSES OF 41 CFR 60-1.4, 60-250.6 AND 60-714.4 ARE INCORPORATED HEREIN BY REFERENCE





EAGLE LANDING GOLF CLUB  
3989 EAGLE LANDING PKWY  
ORANGE PARK FL 32065-2641



SYSCO JACKSONVILLE, INC.  
1501 LEWIS INDUSTRIAL DRIVE  
JACKSONVILLE, FL 32254  
1-800-797-2627 (1-800 SYSCO CS)

904-637-0648

EAGLE LANDING GOLF CLUB  
3989 EAGLE LANDING PKWY  
ORANGE PARK FL 32065 -2641

CUSTOMER'S ORIGINAL INVOICE CONFIDENTIAL PROPERTY OF SYSCO

DELIV. DATE	CUSTOMER	INVOICE NUMBER	PAGE
12/18/24	784966	583008313	4 2
TRUCK STOP			
349/013			
ROUTE	PURCHASE ORDER		
3612	TERMS -PAST DUE BALANCES ARE SUBJECT TO SERVICE CHARGE		
Net 30			
MANIFEST# 1274796 NORMAL DELIVERY			
MA: TVADC SCARLETT BAYLESS			

DRIVER: TEMPLETON

QTY	PACK	SIZE	ITEM DESCRIPTION	ITEM CODE	UNIT PRICE	UNIT TAX AMOUNT	EXTENDED PRICE	INVOICE ADJUSTMENTS	
								CODE	QTY
1	CS	104 LB	SYS CLS SUGAR GRANULATED XFINE CANE 412006	2926727	41.30		41.30		
2S	ONLY1 GAL		SYS CLS VINEGAR DISTILLED WHITE 5% 911123	4113049	5.27		10.54		
3	CS	4016.9OZ	NIAGARA WATER BOTTLED SPRING GROUP TOTAL****	9901031	13.73		41.19		
								232.87	
***PAPER & DISP***									
1	CS	1509X9X3	SYS CLS CONTAINER FOAM HNG 1C D YTD199S10000	7551334	21.02		21.02		
1	CS	2025 CT	DART CUP FOAM TALL 20 OZ 20J16	4088886	27.56		27.56		
1	CS	250CT	SYS CLS KIT CUTLERY MED KFS/S&P YMKFSKWNPSY	0621999	40.61		40.61		
1	CS	10060 GAL	SYS REL LINER REPRO 38X58 1.5 ML X7658AKSX01	1763846	41.77		41.77		
1S	ONLY1000CT		HANGARD PICK BAMBOO FRILL 4 IN 305214009	2102335	4.03		4.03		
1	CS	16250CT	SYS CLS TOWEL MULTIFOLD 9.4X9.2 WHT 4458693	4458693	42.69		42.69		
								177.68	
***PRODUCE***									
1	CS	14 OZ	IMPFRSH BASIL FRESH HERB 00074865229166	2004513	6.38		6.38		
3S	ONLY.5 PT		DRISCOL BLACKBERRY FRESH	3738804	4.15		12.45		
3S	ONLY1 PT		PROPACK BLUEBERRY FRESH 4240	1254390	4.39		13.17		
1	CS	14 LB	IMPFRSH GRAPE RED SDLS FRESH	2463164	23.58		23.58		
1S	ONLY6 CT		SYFFNAT LETTUCE ICEBERG TRIMMED FRESH	1675610	10.84		10.84		
1S	ONLY6 CT		SYFFNAT LETTUCE ROMAINE FRESH 10074865102336	1675891	11.09		11.09		
1	CS	148 CT	PACKER LIME FRESH	1079425	16.58		16.58		
1	CS	13 CT	IMPFRSH MELON CANTALOUPE FRESH	6908115	16.84		16.84		
1S	ONLY5 LB		IMPFRSH ORANGE BAGGED FRESH 10889356163020	7289526	9.24		9.24		

CASES	SPLIT	TOT. PCS	CUBE	GROSS WT.	OPEN: 7:00 AM	CLOSE: 5:00 PM
13	12	25	18.9	322		

REMIT TO	
SYSCO JACKSONVILLE	
1501 LEWIS INDUSTRIAL	
JACKSONVILLE, FL 32254	
SHB TOTAL	904.40

DRIVER'S SIGN	NO. PCS DELVD.	COST. SIGNED INVOICE EVIDENCE OF ALL ITEMS SIGN	NO. PCS REC.
		X	

TAX TOTAL	
INVOICE TOTAL	

IMPORTANT FACT PROVISION: THE PERISHABLE AGRICULTURAL COMMODITIES LISTED ON THIS INVOICE ARE SUBJECT TO THE STATUTORY TRUST AUTHORIZED BY SECTION 5 (C) OF THE PERISHABLE AGRICULTURAL COMMODITIES ACT 1939 (U.S.C. 492E(C)). THE SELLER OF THIS COMMODITY RETAINS A TRUST CLAIM OVER THESE COMMODITIES. ALL INVENTORIES OF FOOD OR OTHER PRODUCTS DERIVED FROM THESE COMMODITIES AND ANY RECEIVABLES OR PROCEEDS FROM THE SALE OF THESE COMMODITIES UNTIL FULL PAYMENT IS RECEIVED. FURTHER, YOU AGREE WITH RESPECT TO ANY DISPUTE ARISING OUT OF YOUR RECEIPT OF THESE PRODUCTS/SERVICES: YOU ARE GIVING UP YOUR RIGHT TO SERVE IN ANY REPRESENTATIVE CAPACITY, OR TO PARTICIPATE AS A MEMBER OF A CLASS OF CLAIMANTS IN ANY LITIGATION INVOLVING ANY SUCH DISPUTE.

PAYABLE ON OR BEFORE  
CONT. ON PAGE 3

EQUAL OPPORTUNITY AND AFFIRMATIVE ACTION CLAUSES OF 41 CFR 60-1.4, 60-250.4 AND 60-714.4 ARE INCORPORATED HEREIN BY REFERENCE



# Invoice

TableTop Linen Rental  
898 Bellevue Ave.  
support@tabletoplinen.com  
Daytona Beach, FL 32114 (386)254-3158

EAGLE LANDING GOLF CLUB  
3989 Eagle Landing Parkway  
Orange Park, FL 32065 (904)860-7177

Date	Invoice	Day	Garment Mark	Freq.	Seq	Term	Account	Route
12/11/2024	0131577	Wed		7	30	CHG	1193-00000	7

Line	Item	Empl	Name / Description	Sizes	Qty.	Min.	OFFICE			ROUTE			Total
							Adj. Qty.	Adj. Amt.	Unit Pr.	Ext. Price	Adj. Qty.	Adj. Amt.	
1	FBNPW		NAPKIN WHITE		200	0	0	\$0.00	\$0.1100	\$22.00	0	\$0.00	\$22.00
2	FBNPW		NAPKIN WHITE		SRC	0	0	\$0.00	\$2.0000	\$4.00	0	\$0.00	\$4.00
3	DGBAGST		BAG STAND			0	0	\$0.00	\$0.0100	\$0.02	0	\$0.00	\$0.02
4	FB8585W		TC 85X85 WHITE		90	0	0	\$0.00	\$1.4700	\$132.30	0	\$0.00	\$132.30
5	FBMESBAG		MESH BAG		10	0	0	\$0.00	\$0.0100	\$0.10	0	\$0.00	\$0.10
6	DGCARTHAM		CART HAMPER			0	0	\$0.00	\$0.0100	\$0.01	0	\$0.00	\$0.01
7	TPP		TOTAL PROTECTION PLAN					\$0.00		\$6.49		\$0.00	\$6.49
			Delivery Charge					\$0.00		\$15.70		\$0.00	\$15.70

Office Adj.:	\$0.00	Subtotal:	\$180.62	Rte. Adj.:	\$0.00
Tax Adj.:	\$0.00	Sales Tax:	\$13.06	Tax Adj.:	\$0.00
Net Adj.:	\$0.00	Prebill:	\$193.68	Net Adj.:	\$0.00

Total Adj.: \$0.00  
Tax Adj.: \$0.00

**Net Charge: \$193.68**

Comment: \_\_\_\_\_

Received By: \_\_\_\_\_ N 12/11/2024 4:19:51PM

*[Handwritten signatures and notes]*  
 12/11/24  
 12/18/24  
 Renew  
 240-1346  
 \$193.68

**Troon Golf LLC**

15044 N Scottsdale Road  
Suite 300  
Scottsdale, AZ 85254  
USA

**Invoice**



Page	1 of 1	A00468: Eagle Landing GC
Invoice number	ARINV-1010-172453	
Date	12/13/2024	FL USA
Project contract	A00468	
Customer account	10221	
Payment terms		
Currency	USD	

Expense	Category	Description	Employee	Date	Merchant	Original amount (FX)	Original currency	FX Rate	Amount
	BILL TO PROP - TRAVEL COSTS	Site visit Jim DeReuil	James J De Reuil	11/4/2024	BP#9088352TA MARIANQPS	58.68	USD	1.0000	58.68 USD
	Sub total								58.68 USD
	BILL TO PROP-IT SOFTWARE	AZURE ARC Services - Nov 2024				190.00	USD	1.0000	190.00 USD
	Sub total								190.00 USD
Expense	Category	Description	Employee	Date	Merchant	Original amount (FX)	Original currency	FX Rate	Amount
	BILL TO PROP - TRAVEL COSTS	Site visit Jim DeReuil	James J De Reuil	11/7/2024	HILTON GARDEN INN ORA	178.71	USD	1.0000	178.71 USD
	BILL TO PROP - TRAVEL COSTS	Site visit Jim DeReuil	James J De Reuil	11/7/2024	SHELL OIL 10069511009	54.11	USD	1.0000	54.11 USD
	Sub total								232.82 USD
	Sales subtotal amount	Net amount	Sales or Withholding tax						Total
	481.50	481.50	0.00						481.50 USD

**Remittance:**

Send electronic payment to:  
Account Name: Troon Golf LLC  
Bank: JP Morgan, New York, NY 10081  
Account #: 689212314  
ABA/Routing #: 021000021 (for wire transfers)  
ABA/Routing #: 122100024 (for ACH transfers)

*DU - 7150*  
*8*  
*AK*  
*12/23/25*



# Invoice

Reference Nbr.: 007397  
 Date: 18-Dec-2024  
 Due Date: 17-Jan-2025  
 Customer ID: C0000559  
 Master Inv Total: 3,121.12

Trigon Turf Sciences  
**New Address**  
 Department # 5612  
 P.O. Box 25008  
 Bradenton, FL, 34206-5008  
 Phone: 757-220-4466

**TOTAL Invoice: 3,121.12**

**BILL TO:**  
 Eagle Landing Golf Club  
 890 Oakleaf Plantation Pkwy  
 Orange Park FL 32065  
 United States of America

**SHIP TO:**  
 Eagle Landing Golf Club  
 890 Oakleaf Plantation Pkwy  
 Orange Park FL 32065  
 United States of America  
 Attn: Jon Roe

CUSTOMER REF. NBR.		TERMS	CONTACT			
NO.	ITEM	Net 30	QTY.	UOM	UNIT PRICE	EXTENDED PRICE
1	10101: ProteSyn		2.00	CASE	315.00	630.00
2	10369: GlycoFuze		2.00	CASE	325.00	650.00
3	10253: Knife Plus		2.00	CASE	320.00	640.00
4	10424: X-Factor (24-0-0)		2.00	CASE	255.00	510.00
5	10310: Fights-ON		1.00	CASE	340.00	340.00
6	Freight ShipVia		1.00		143.37	143.37

7760-400  
 12/19/24  
 FF

*[Handwritten signature]*  
 12/23/24

NOTE:

Tax Total: 207.75

<b>TOTAL Invoice:</b>	3,121.12
<b>Balance Remaining :</b>	3,121.12

ACCOUNT NO. 91221150    INVOICE NO. 1458513    INVOICE DATE 12/17/24    CUSTOMER NO. 11221140    PURCHASE ORDER NUMBER    SALES LOC. 3055    SALES REP. 0832    DATE ORDERED 12/15/24

ORDER NUMBER: 977067

Bill To: SU VILLAGE COMM DEV DISTR  
3989 EAGLE LANDING PKWY  
ORANGE PARK FL 32065  
Att: CHRIS COLLETTI

Ship To: TRN EAGLE LANDING GLF CLB  
3989 EAGLE LANDING PKWY  
ORANGE PARK FL 32065  
904 291 5600  
DEPT # 00

Remit To: US Foods, Inc  
P.O. BOX 198421  
ATLANTA GA 30384-8421  
304 763 1304

1g From: 5425 E. WILLIAMSON BLVD PORT ORANGE FL 32129 12/17/24 Page 03 of 04  
t Trms: DRIVER MUST LEAVE FINAL RECEIPT FOR INV CHANGES  
6 Trms: NET 21 DAYS

Qty	Sales Unit	Product Number	Description	Pack Size	Label	Weight	Pricing Unit	Unit Price	Extended Price
-----	------------	----------------	-------------	-----------	-------	--------	--------------	------------	----------------

TOTAL NET WGT	1155.22	*** INVOICE SUMMARY ***	PIECES ORDERED: 66	PIECES SHIPPED: 66	ITEMS SHIPPED: 52	PRODUCT TOTAL \$	3157.73
TOTAL GROSS WGT	1270.90					TAXABLE AMOUNT \$	.00
						TEN SALES TAX	.00

This amount is an estimate at time of shipping prior to any adjustments made at delivery. \$ 3157.73

\*\*\*\*\*  
\* You agree with respect to any dispute arising out of your purchase from  
\* US Foods: (i) you are giving up your right to serve in any representative  
\* capacity, or to participate as a member of a class, in any lawsuit; (ii) you  
\* also agree, at US Foods' sole option, to submit to binding, individual  
\* arbitration of all claims; (iii) such arbitration shall be governed by the  
\* Federal Arbitration Act, 9 U.S.C. s.1 and conducted in accordance with the  
\* Commercial Rules of the American Arbitration Association; and (iv) each party  
\* shall pay half the costs of arbitration, and separately pay its own attorneys'  
\* fees and costs. For more information about the fuel surcharge, go to:  
\* <https://www.usfoods.com/terms/fuelsurcharge/StandardGridEIAAreaLowerAtlantic.h>  
\* tal  
\* If you have an agreement with US Foods that expressly addresses the  
\* calculation of the fuel surcharge, please refer to that agreement.  
\*\*\*\*\*

*[Handwritten signature]*  
*[Handwritten initials]*

000  
240-1340 = 2610.74  
240-7450 = 235.94  
240-7444 = 311.05  
Total = 3157.73

ACCOUNT NO. 91221150 INVOICE NO. 1458513 INVOICE DATE 12/17/24 CUSTOMER NO. 11221140 PURCHASE ORDER NUMBER SALES LOC 3055 SALES REP. 0932 DATE ORDERED 12/15/24

Route: R325 / 4

ORDER NUMBER: 977067

Bill To: 30 VILLAGE COMM DEV DISTR  
3989 EAGLE LANDING PKWY  
ORANGE PARK FL 32065  
CHRIS COLLETTI

Ship To: TRN EAGLE LANDING SLP CLM  
3989 EAGLE LANDING PKWY  
ORANGE PARK FL 32065  
904 291 5600  
DEPT # 00

Remit To: US Foods, Inc  
P O BOX 103421  
ATLANTA GA 30384-8421  
304 763 1504

5425 S. WILLIAMSON BLVD PORT ORANGE FL Sales 12/15/24 Page 01 of 04  
Special DRIVER MUST LEAVE FINAL RECEIPT FOR INV CHANGES  
NET 21 DAYS

Qty	Sales Unit	Product Number	Description	Pack Size	Label	Weight	Pricing Unit	Unit Price	Extended Price
-----	------------	----------------	-------------	-----------	-------	--------	--------------	------------	----------------

HAZARDOUS MATERIALS

1	CS	2840726	DRY TERGENT, DSHWR SOLID FOWER 4/9 LB 0454-SODIUM HYDROXIDE, SOLID, MIXTURE	4/9 LB	ECOLAB		CS	127.0200	127.02
*****									
TOTAL HAZARDOUS WEIGHT: 36.00 TOTAL HAZARDOUS PIECES: 1 TOTAL HAZARDOUS CUBE: .68									
*****									

1	CS	1002005	DRY FOIL, ALUM 18"X500' STD PL	1 RL	REYNOLDS		CS	52.8000	52.80 ✓
1	CS	1005586	GRAVY, SSG CNTRY STYL	6/105 OZ	CHEF MATE		CS	70.4300	70.43
1	CS	1204361	DRINK, LNM LIME PLST BTL WIDE	24/29 OZ	GATORADE		CS	23.9800	23.98
3	CS	1328699	SHORTENING, FRYG SOYBN LIQ CLR	35 LB	HARVEST VL		CS	32.5600	97.68
1	CS	1457016	CUP, SFLE POLYP 2 Z CLR PTN	13/200 EA	OXIC		CS	41.5200	41.52 ✓
1	CS	1931237	SHELL, CNOLI .5 Z TFF MINI	120/1.5 OZ	BRKLYN CHL		CS	29.9300	29.93
1	CS	2816080	SCRUBBER, 9/8 1.25 Z HD PAD	4/12 EA	3M SCOTCH		CS	71.0200	71.02
1	CS	3112695	DRINK, SODA COLA DIET COKE CAN	24/12 OZ	COKE		CS	18.2900	18.29
1	CS	3554565	DRINK, SODA COLA COKE CLSC CAN	24/12 OZ	COKE		CS	18.2900	18.29
1	EA	4146478	SEASONING, STK MNTRL RUB SHLF	7 LB	MCCORMICK		EA	49.0300	49.03
1	CS	4959854	RINSE ADDITIVE, DSHWR D28 E-Z	5 LT	HONORANCE		CS	102.9800	102.98
1	CS	5051368	TORTILLA, CHIP RAW 4 CUT TRI	30 LB	LA BNDRITA		CS	31.1700	31.17
1	CS	5204151	SAUCE, CHG NACHO SHLF STABL	6/110 CN	ROCARITA		CS	89.1400	89.14
2	CS	5651351	GLOVE, VINYL XL PF CLR AMBX	10/100 EA	VALUGARDS		CS	21.6300	43.26 ✓
1	CS	7520950	SAUCE, PIZA TRTD CAN SHLF	6/110 CN	PIZZAIOLE		CS	41.7900	41.79
1	CS	8009235	LID, CONT 8 Z VTD DOME PLST	10/100 EA	DART		CS	37.5600	37.56 ✓
1	CS	8600645	CUP, PET PLST 12 Z CLD CLR	20/50 EA	DART		CS	60.8000	60.80 ✓
1	CS	9395781	SCRUBBER, SYTHC FIBR 6X9 GRN	20 EA	NIAGARA		CS	9.0300	9.03
1	CS	9837683	SAUCE, GRLO PARM PLET JAR SHLF	4/1.5 GA	SWEET 1681		CS	38.8100	38.81
REFRIGERATED									
1	CS	0454210	PEPPER, BELL GREEN CHOICE FRESH	1 LB	PACKER		CS	17.6900	17.69
1	CS	0813013	EGG, SHL LB GRD AA UNF LACS FRTS	5 LB	CLAW EGG		CS	55.8700	55.87
1	EA	1326438	ONION, GRN TRMD ICELS FRESH	2 LB	CROSS VALY	B	EA	4.7900	4.79
READY TO EAT - Please Refer to Return Policy									
1	CS	2331353	TOMATO, RND 5X6 #1 GRD FRESH	25 LB	CROSS ONLY		CS	60.6100	60.61
1	EA	2348936	CARROT, STICK 3 3/4" FRESH	5 LB	CROSS VALY	F	EA	8.9400	8.94
READY TO EAT - Please Refer to Return Policy									

ACCOUNT INVOICE INVDATE CUSTOMER PURCHASE ORDER  
 NO NO DATE NO NUMBER  
 91221150 1458513 12/17/24 11221140

SALES SALES DATE  
 LOC REP ORDERED  
 7055 0832 12/15/24

Route 2325 / 6

ORDER NUMBER 977067

Bill To: 3D VILLAGE COMM DEV DISTR  
 3989 EAGLE LANDING PKWY  
 ORANGE PARK FL 32065  
 Att: CHRIS COLLETTI

Ship To: TRN EAGLE LANDING GUT CLR  
 3989 EAGLE LANDING PKWY  
 ORANGE PARK FL 32065  
 904 291 5600  
 DEPT # 00

Remit To: U's Foods, Inc  
 P O BOX 198421  
 ATLANTA GA 30384-8421  
 534 753 1304

Ship From: 5425 S. WILLIAMSON BLVD PORT ORANGE FL Ship Date: 12/17/24 Page 08 of 04  
 Terms: NET 21 DAYS Special Instr: DRIVER MUST LEAVE FINAL RECEIPT FOR INV CHANGES

Qty	Sales	Product	Description	Pack Size	Label	Weight	Pricing Unit	Unit Price	Extended Price
3	CS	2721173	CHICKEN, WING 182JT JMB RAW	4/10 LB	PATUXENT		CS	94.1200	282.36
2	CS	2725711	CHICKEN, BRST SMGL 6 Z BMLS	4/5 LB	PATUXENT		CS	68.1100	136.22
1	CS	3331998	BROCCOLI, FLORT MINI ICELS REF4/3 LB		CROSS VALY		CS	39.9700	39.97
			READY TO EAT - Please Refer to Return Policy						
1	CS	4284530	PEPPER, BELL RED CHO FRESH REFS LB		PACKER		CS	16.0100	16.01
1	CS	5327275	BEEF, PTY GRND 80/20 2-1 RND	20/8 OZ	CYLN BILT		CS	42.6600	42.66
1	EA	6712374	CANDY, SNCKR BAR SS IW REF Z	1.86 OZ	SNICKERS	B	EA	50.2900	50.29
1	EA	7331614	CELERY, STICK 4" FRESH REF	4/5 LB	CROSS VALY	P	EA	10.2600	10.26
			READY TO EAT - Please Refer to Return Policy						
1	CS	8231189	LEMON, CHO IMP 3 DMSTC 165 CT 165 EA		PACKER		CS	45.4100	45.41
1	CS	8901336	VEGETABLE BLEND, SLC PBLND BELS LB		CROSS VALY		CS	22.8400	22.84
			READY TO EAT - Please Refer to Return Policy						
1	CS	0488239	FROZEN ROLL, HOGI WHT 8" SLCD BKD FZNS6/6/3.7 OZ		COSTANZO'S		CS	31.0200	31.02
1	CS	0831412	EGG, LIQ MIX W/ MILK PSRD CIBS7E LB		GLVND FRMS		CS	48.5200	48.52
1	CS	1317973	BISCUIT, BTRMLK 2.25 Z UMSL 120/2.25 OZ		PILLSBURY		CS	36.4300	36.43
1	CS	1475608	BREAD, FLAT 5X13" OVAL BKD FZNS6/3 81 OZ		STONEFNT		CS	26.2900	26.29
1	CS	2122328	BEEF, STK T8D TP CC 1184B 60ZA24/6 OZA		STOCK YRDS	9.00	LB	11.4200	102.78
			CS: 0001 9.00 LBS						
1	CS	2633394	BREAD, RYE MRBL 17 SLCD 5/8" 6/30 OZ		EURO BAKRY		CS	37.7300	37.73
4	CS	2883130	POTATO, FF SC 3/8" EXTRA CRSPY2/5 LB		MONARH		CS	50.1300	200.52
1	CS	2984721	CRAB CAKE, CLAW HMSTY .75 Z 100/75 OZ		HARBOR BHK		CS	73.9000	73.90
1	CS	3200145	SALMON, ATLNTC 6 Z PTN PBD 3D 10 LB		HARBOR BHK		CS	100.1900	100.19
1	CS	3330099	HOT DOG, AB 6:1 6" RLR GRIL 10 LB		PATUXENT		CS	31.3500	31.35
2	CS	4358495	BACON, PORK 18-22C SLC LAID 2015 LB		PATUXENT		CS	62.4500	124.85
1	CS	5072673	FILLING, CRN CHOC CHIP CNOLI 4/1.5 LB		SPECTTOUCH		CS	46.9800	46.98
1	CS	5915319	APPETIZER, CHS MOZZ BRDD 8/2 LB		LAMB WEST		CS	64.9800	64.98
3	CS	6553758	ROLL, KSR WHT 4.5" SLCD BKD 6/8/3.5 OZ		ROTELLA		CS	31.8100	95.43
1	CS	6911663	PANGASIU, STPED 5-7 Z FIL P8015 LB		HARBOR BHK		CS	39.0900	39.09
3	CS	7637713	CHICKEN, TNDLN BTRD FRITR BEER2/5 LB		PATUXENT		CS	39.9600	119.88
1	CS	7946221	MANGO, CUBE 3/8" IMP MEXD IQF 2/5 LB		MONARH		CS	32.3400	32.34
1	CS	9205147	BEEF, PTY GRND 75/25 3:1 HMSTY60/5.33 OZ		TNTTYTND		CS	85.0000	85.00

STORAGE LOCATION RECAP(N)

TOTAL DRY	PIECES ORDERED:	23	PIECES SHIPPED:	23	ITEMS SHIPPED:	20	1055.53
TOTAL REFRIGERATED	PIECES ORDERED:	17	PIECES SHIPPED:	17	ITEMS SHIPPED:	14	803.92
TOTAL FROZEN	PIECES ORDERED:	26	PIECES SHIPPED:	26	ITEMS SHIPPED:	18	1298.28



ACCOUNT NO. 91221150 INVOICE NO. 1458514 INVOICE DATE 12/17/24 CUSTOMER NO. 11221140 PURCHASE ORDER NUMBER

SALES LOC. 3055 SALES REP. 0832 DATE ORDERED 12/18/24

Route: 2325 / 6

ORDER NUMBER: 977440

Bill To:

50 VILLAGE COMM DEV DISTR  
3989 EAGLE LANDING PKWY  
ORANGE PARK FL  
32065

Ship To:

TRN EAGLE LANDING OLF OLD  
3989 EAGLE LANDING PKWY  
ORANGE PARK FL  
32065  
904 291 5600  
DEPT # 00

Remit To:

US Foods, Inc  
P.O. BOX 198421  
ATLANTA GA  
30384-8421  
304 763 1304

Att: CHRIS COLLETTI

From: 5425 S WILLIAMSON BLVD PORT ORANGE FL

Ship Date: 12/17/24

Page 01 of 02

Terms: NET 21 DAYS Special Instr: DRIVER MUST LEAVE FINAL RECEIPT FOR INV CHANGES

Qty	Sales Unit	Product Number	Description	Pack Size	Label	Weight	Pricing Unit	Unit Price	Extended Price
-----	------------	----------------	-------------	-----------	-------	--------	--------------	------------	----------------

2	CS	2725711	REFRIGERATED CHICKEN, BRST SNGL 6 Z BNLS	4/5 LB	FATUXENT		CS	68.1100	\$ 136.22
---	----	---------	--	--------	----------	--	----	---------	-----------

1	CS	2883130	FROZEN POTATO, FF SC 3/8" EXTRA CRSPY	6/5 LB	NONAGEN		CS	50.1300	50.13
---	----	---------	---------------------------------------	--------	---------	--	----	---------	-------

STORAGE LOCATION RECAP(N)

TOTAL REFRIGERATED	PIECES ORDERED:	2	PIECES SHIPPED:	2	ITEMS SHIPPED:	1	136.22
TOTAL FROZEN	PIECES ORDERED:	1	PIECES SHIPPED:	1	ITEMS SHIPPED:	1	50.13

\*\*\* INVOICE SUMMARY \*\*\*  
TOTAL NET WGT: 70.00  
TOTAL GROSS WGT: 74.92  
PIECES ORDERED: 3  
PIECES SHIPPED: 3  
ITEMS SHIPPED: 2

PRODUCT TOTAL \$ 186.35

TAXABLE AMOUNT \$ 00  
GEN SALES TAX % .00

This amount is an estimate at time of shipping prior to delivery. Total amount at delivery \$ 186.35

*Handwritten signature and calculation:*  
000  
240-1340 = 186.35

ACCOUNT NO. 71221150 INVOICE NO. 1458515 INVOICE DATE 12/17/24 CUSTOMER NO. 11221140 PURCHASE ORDER NUMBER

SALES LOC. 3055 SALES REP. 0932 DATE ORDERED 12/15/24

Route 2325 / 6

ORDER NUMBER: 977462

Bill

To: 50 VILLAGE COMM DEV DISTR  
3989 EAGLE LANDING PKWY  
ORANGE PARK FL  
32065

Ship

To: TRM EAGLE LANDING GLF CLV  
3989 EAGLE LANDING PKWY  
ORANGE PARK FL  
32065  
904 291 5600  
DEPT # 00

Remit

To: US Foods, Inc.  
P O BOX 198421  
ATLANTA GA  
30384-8421  
304 443 1304

Att: CHRIS COLLETTE

igFrom: 5425 S. WILLIAMSON BLVD PORT ORANGE FL

Ship Date: 12/17/24  
Serial Instr:

Page 01 of 02  
DRIVER MUST LEAVE FINAL RECEIPT FOR INV CHANGES

tTrms: NET 21 DAYS

Qty Sales Product  
lered shipped Unit Number

Description

Pack Size

Label

Weight

Pricing Unit

Unit Price

Extended Price

1	CS	2511301	FROZEN GROUPER, BRDD TENDR PARFR FISH4/2 LB	TAMPA MAID	CS	417.4300	4	117.43
---	----	---------	---	------------	----	----------	---	--------

STORAGE LOCATION RECAP(N)

TOTAL FROZEN	PIECES ORDERED	1	PIECES SHIPPED	1	ITEMS SHIPPED	1	117.43
--------------	----------------	---	----------------	---	---------------	---	--------

TOTAL NET WGT:	12.00	*** INVOICE SUMMARY ***
TOTAL GROSS WGT:	13.80	PIECES ORDERED

PIECES SHIPPED	1	ITEMS SHIPPED	1
----------------	---	---------------	---

PRODUCT TOTAL 4 117.43

TAXABLE AMOUNT \$ 00  
GEN SALES TAX % 00

This amount is an estimate at time of shipping prior to any adjustments made at delivery. \$ 117.43

*Chris Collette*  
12/17/24

000  
~~240-1340~~ = 117.43

ACCOUNT NO. 71221150    INVOICE NO. 1458916    INVOICE DATE 12/17/24    CUSTOMER NO. 11221140    PURCHASE ORDER NUMBER    SALES LOC 3053    SALES REP. 0832    DATE ORDERED 12/15/24

ORDER NUMBER: 977570

Bill

To:

50 VILLAGE COMM DEV DISTR  
3989 EAGLE LANDING PKWY  
  
ORANGE PARK FL  
32065

Ship

To:

Route: 2325 / 6  
TRN EAGLE LANDING GLF CLB  
3989 EAGLE LANDING PKWY  
  
ORANGE PARK FL  
32065  
904 291 5500  
DEPT # 00

Remit

To:

US Foods, Inc.  
  
P.O. BOX 198421  
  
ATLANTA GA  
30384-8421  
888 753 1304

Att:

CHRIS COLLETTI

From: 5425 S WILLIAMSON BLVD PORT ORANGE FL

Ship Date: 12/17/24

Page 01 of 02

Terms: NET 21 DAYS    Special Instr. DRIVER MUST LEAVE FINAL RECEIPT FOR INV CHANGES

Qty	Sales Unit	Product Number	Description	Pack Size	Label	Weight	Pricing Unit	Unit Price	Extended Price
-----	------------	----------------	-------------	-----------	-------	--------	--------------	------------	----------------

1	CS	6754661	DRY CLEANER, FLR F6 E-2 LIQ BTL	5 LT	MONOGRANCF		CS	77.5300	77.53
---	----	---------	---------------------------------	------	------------	--	----	---------	-------

STORAGE LOCATION RECAP(N)

TOTAL DRY			PIECES ORDERED: 1	PIECES SHIPPED: 1	ITEMS SHIPPED: 1				77.53
-----------	--	--	-------------------	-------------------	------------------	--	--	--	-------

TOTAL NET WGT:	11.24	*** INVOICE SUMMARY ***	PIECES ORDERED: 1	PIECES SHIPPED: 1	ITEMS SHIPPED: 1				
TOTAL GROSS WGT:	12.20								

PRODUCT TOTAL \$ 77.53

TAXABLE AMOUNT \$ 00  
GEN SALES TAX % 00

This amount is an estimate at time of shipping price to be made at delivery: 77.53

*Handwritten signature and date: 12/23/24*

500-7444 = 77.53

ACCOUNT INVOICE INVOICE CUSTOMER PURCHASE ORDER  
 NO. NO. DATE NO. NUMBER  
 91221150 1591746 12/20/24 11221140

SALES SALES DATE  
 LOC. REP. ORDERED  
 3055 0832 12/19/24

ORDER NUMBER: 987178

Bill

To:

SO VILLAGE COMM DEV DISTR  
 3989 EAGLE LANDING PKWY  
  
 ORANGE PARK FL  
 32065

Ship

To:

TRN EAGLE LANDING GLF CLB  
 3989 EAGLE LANDING PKWY  
  
 ORANGE PARK FL  
 32065  
 904 291 5600  
 DEPT # 00

Remit

To:

US Foods, Inc.  
 P.O. BOX 198421  
  
 ATLANTA GA  
 30384-8421  
 386 763 1304

Att:

CHRIS COLLETTI

1pFrm: 5425 S. WILLIAMSON BLVD PORT ORANGE

FL ShipD: 12/20/24

Page 03 of 04

tTrms: NET 21 DAYS DRIVER MUST LEAVE FINAL RECEIPT FOR INV CHANGES

ty	Qty	Sales	Product	Description	Pack Size	Label	C	Weight	Pricing	Unit	Extended
ferred	Shipped	Unit	Number				D		Unit	Price	Price

TOTAL NET WGT: 1032.32 \*\*\* INVOICE SUMMARY \*\*\*  
 TOTAL GROSS WGT: 1118.24 PIECES ORDERED: 61 PIECES SHIPPED: 61 ITEMS SHIPPED: 44

PRODUCT TOTAL \$ 2583.29

TAXABLE AMOUNT \$ .00  
 GEN SALES TAX % .00

This amount is an estimate at time of shipping prior to any adjustments made at delivery: \$ 2583.29

\*\*\*\*\*  
 \* You agree with respect to any dispute arising out of your purchase from \*  
 \* US Foods: (i) you are giving up your right to serve in any representative \*  
 \* capacity, or to participate as a member of a class, in any lawsuit; (ii) you \*  
 \* also agree, at US Foods sole option, to submit to binding, individual \*  
 \* arbitration of all claims; (iii) such arbitration shall be governed by the \*  
 \* Federal Arbitration Act, 9 U.S.C. s.1 and conducted in accordance with the \*  
 \* Commercial Rules of the American Arbitration Association; and (iv) each party \*  
 \* shall pay half the costs of arbitration, and separately pay its own attorneys' \*  
 \* fees and costs. For more information about the fuel surcharge, go to: \*  
 \* https://www.usfoods.com/terms/fuelsurcharge/StandardGridEIAAreaLowerAtlantic.h \*  
 \* tml \*  
 \* If you have an agreement with US Foods that expressly addresses the \*  
 \* calculation of the fuel surcharge, please refer to that agreement. \*  
 \*\*\*\*\*

*[Handwritten signature]*

000  
 240-1340 = 2245.14  
 500-7444 = 48.59  
 500-7450 = 222.58  
 240-7444 = 66.98  
 Total = 2583.29

ACCOUNT INVOICE INVOICE CUSTOMER PURCHASE ORDER  
 NO. NO. DATE NO. NUMBER  
 91221150 1591746 12/20/24 11221140

SALES SALES DATE  
 LOC. REP. ORDERED  
 3055 0832 12/19/24

Route: 5332 / 4

ORDER NUMBER: 987178

Bill To: SD VILLAGE COMM DEV DISTR  
 3989 EAGLE LANDING PKWY  
 ORANGE PARK FL  
 32065  
 Attn: CHRIS COLLETTI

Ship To: TRN EAGLE LANDING GLF CLB  
 3989 EAGLE LANDING PKWY  
 ORANGE PARK FL  
 32065  
 904 291 5600  
 DEPT # 00

Remit To: US Foods, Inc.  
 P.O. BOX 198421  
 ATLANTA GA  
 30384-8421  
 386 763 1304

ipFrom: 5425 S. WILLIAMSON BLVD PORT ORANGE FL ShipD: 12/20/24 Page 01 of 04  
 tTrms: Special DRIVER MUST LEAVE FINAL RECEIPT FOR INV CHANGES  
 tTrms: NET 21 DAYS Instr:

Qty	Sales Unit	Product Number	Description	Pack Size	Label	C D	Weight	Pricing Unit	Unit Price	Extended Price
1	0	CS 0719427	DRY							
SUB**	1	CS 3256104	LID, CUP 12-20 Z PLST WHT SLO	10/100 EA	MONOGRAM				\$	
1	1	CS 0728865	LID, CUP 12-24 Z BRL PLST	1000 EA	WINCUP			CS	31.1800	31.18 ✓
1	1	EA 0778670	CUP, FM 12 Z WHT	40/25 EA	MONOGRAM			CS	34.2700	34.27 ✓
2	2	CS 1328699	WRAP, 10.75X10 WAX PAPER WHT	500 EA	MONOGRAM	B		EA	5.9300	11.86 ✓
1	1	CS 1486695	SHORTENING, FRYG SOYBN LIQ CLR	35 LB	HARVEST VL			CS	32.5600	65.12 ✓
1	1	CS 2008860	WIPE, FDSV CLTH 14.9X16.6 WHT	300 EA	WYPALL			CS	48.0700	48.07 ✓
2	2	CS 3554565	MUSTARD, YLW SS POUCH	500/.2 OZ	HEINZ			CS	15.6200	15.62 ✓
1	1	CS 3554649	DRINK, SODA COLA COKE CLSC CAN	24/12 OZ	COKE			CS	18.2900	36.58
1	1	EA 4523510	DRINK, SODA DIET COKE ZERO	24/12 OZ	COKE ZERO			CS	18.2900	18.29
2	2	CS 5651351	CHERRY, MRCMD W/ STEM LG PLST	.5 GA	MONARCH	B		EA	18.3900	18.39
1	1	CS 6002398	GLOVE, VINYL XL PF CLR AMBOX	10/100 EA	VALUGARDS			CS	21.6300	43.26 ✓
2	2	CS 6345599	KETCHUP, TMTD FCY 33% SS FOIL	1000/9 BR	HEINZ			CS	27.3000	27.30
1	1	CS 6733182	DETERGENT, BAR GLS MNL BEER	100/.5 OZ	DIVERSEY			CS	33.4900	66.98
1	1	CS 7802523	CEREAL, OTML ASST INST SS	64 EA	QUAKER			CS	22.8700	22.87
1	1	CS 9351990	NAPKIN, DNMR WHT 17X17 1 PLY	20/250 EA	VALU PLUS			CS	53.9400	53.94 ✓
1	1	CS 9837873	CLEANER, DISINF CLEAN-UP LIQ	9/32 OZ	CLOROX			CS	48.5900	48.59
			SAUCE, MANGO HABAN GLTN/FR	4/.5 GA	SWEET BABY			CS	42.9200	42.92
			REFRIGERATED							
1	1	EA 0198721	CANDY, PNT BUTR CUP RESES	36 EA	REESE'S	B		EA	37.7200	37.72
1	1	CS 1213404	DRESSING, BLU CHS PLST JAR REF	4/1 GA	KEN'S			CS	73.9800	73.98
1	1	CS 2326411	LETTUCE, ICBRG FRESH REF BOX	24 EA	CROSS VALY			CS	50.3400	50.34
3	3	CS 2721173	CHICKEN, WING 182JT JMB RAW	4/10 LB	PATUXENT			CS	94.1200	282.36
1	1	CS 2725711	CHICKEN, BRST SNGL 6 Z BNLS	4/5 LB	PATUXENT			CS	68.1100	68.11
1	1	CS 2971551	HAM, SLCD .67 Z W/A SMKD CKD	6/2 LB	HILLSHIRE			CS	48.6900	48.69
			READY TO EAT - Please Refer to Return Policy							
1	1	CS 3340510	CHEESE, AMER SLCD 120 CT TFF	4/5 LB	GLNVW FRMS			CS	53.7700	53.77
1	1	CS 4284530	PEPPER, BELL RED CHO FRESH REF	5 LB	PACKER			CS	16.0100	16.01
1	1	CS 4472337	FRUIT MIX, 5 WAY IN WATER NO	8 LB	CROSS VALY			CS	28.7900	28.79
			READY TO EAT - Please Refer to Return Policy							
1	1	CS 5326418	LETTUCE, RMN FRESH REF	24 EA	CROSS VALY			CS	40.3800	40.38
3	3	CS 5327275	BEEF, PTY GRND 80/20 2:1 RND	20/8 OZ	CTLMN SLET			CS	42.6600	127.98
1	1	EA 7331614	CELERY, STICK 4" FRESH REF	4/5 LB	CROSS VALY	B		EA	10.2600	10.26
			READY TO EAT - Please Refer to Return Policy							
1	1	CS 8350258	MILK, WHL PSTRD RBST FREE D	4/1 GA	GLNVW FRMS			CS	27.8400	27.84
1	1	CS 9124520	DRESSING, RANCH HMSTY PLST JAR	4/1 GA	KEN'S			CS	46.0800	46.08
			READY TO EAT - Please Refer to Return Policy							

ACCOUNT INVOICE INVOICE CUSTOMER PURCHASE ORDER  
 NO. NO. DATE NO. NUMBER  
 91221150 1591746 12/20/24 11221140

SALES SALES DATE  
 LOC. REP. ORDERED  
 3055 0832 12/19/24

Route: 5332 / 4

ORDER NUMBER: 987178

Bill

To:

SD VILLAGE COMM DEV DISTR  
 3989 EAGLE LANDING PKWY  
  
 ORANGE PARK FL  
 32065

Ship

To:

TRN EAGLE LANDING GLF CLB  
 3989 EAGLE LANDING PKWY  
  
 ORANGE PARK FL  
 32065  
 904 291 5600  
 DEPT # 00

Remit

To:

US Foods, Inc.  
  
 P.O. BOX 198421  
  
 ATLANTA GA  
 30384-8421  
 386 763 1304

Att: CHRIS COLLETTI

igFrm: 5425 S. WILLIAMSON BLVD PORT ORANGE FL

ShipD: 12/20/24

Page 02 of 04

tTrms: DRIVER MUST LEAVE FINAL RECEIPT FOR INV CHANGES

tTrms: NET 21 DAYS

by	Qty	Sales	Product	Description	Pack	Size	Label	C	Weight	Pricing	Unit	Extended
ferred	Shipped	Unit	Number					D		Unit	Price	Price

				FROZEN								
1	1	CS	0488239	ROLL, HOGI WHT 8" SLCD BKD FZNB/6/3.7 OZ			COSTANZO'S			CS	31.0200	31.02
1	1	CS	1054265	BUN, HOT DOG WHT 6" SLCD CKD 8/12/1.7 OZ			HILLTOP HR			CS	25.6000	25.60
1	1	CS	1739275	DOUGH, DNSH ASST BAG FZN 4/12 EA			BEL PASTRY			CS	55.2400	55.24
5	5	CS	2883130	POTATO, FF SC 3/8" EXTRA CRSPY6/5 LB			MONARCH			CS	50.1300	250.65
1	1	CS	4358495	BACON, PORK 18-22C SLC LAID 2015 LB			PATUXENT			CS	62.4300	62.43
1	1	CS	4790135	CROISSANT, PLN 2 Z PINHD SLCD 64/2 OZ			PILLSBURY			CS	39.2800	39.28
1	1	CS	5141759	CAKE, LAYR 2 CHOC ICED 9" 14 4/100 OZ			SWEET ST			CS	184.9900	184.99
2	2	CS	5915319	APPETIZER, CHS MOZZ BRDD 6/2 LB			LAMB WESTN			CS	64.9800	129.96
1	1	CS	6196745	SAUSAGE, SESD CRBL PORK W/ TVP2/5 LB			HORMEL			CS	31.5600	31.56
3	3	CS	6553758	ROLL, KSR WHT 4.5" SLCD BKD 6/8/3.5 OZ			ROTELLA			CS	31.8100	95.43
1	1	CS	7233562	MACARONI & CHEESE, CHEDR PRCKD36/7 OZ			KRAFT			CS	36.9100	36.91
2	2	CS	7637713	CHICKEN, TNDLN BTRD FRTR BEER2/5 LB			PATUXENT			CS	39.9600	79.92
1	1	CS	9042674	CAKE, LOAF LMN ICED 4 Z SS IW 20/4 OZ			CHEFS LINE			CS	29.0100	29.01
1	1	CS	9786507	CAKE, COF CIN CRMB NOT ICED 21/3.5 OZ			CHEFS LINE			CS	33.7400	33.74

STORAGE LOCATION RECAP(N)

TOTAL DRY	PIECES ORDERED:	21	PIECES SHIPPED:	21	ITEMS SHIPPED:	16	585.24
TOTAL REFRIGERATED	PIECES ORDERED:	18	PIECES SHIPPED:	18	ITEMS SHIPPED:	14	912.31
TOTAL FROZEN	PIECES ORDERED:	22	PIECES SHIPPED:	22	ITEMS SHIPPED:	14	1085.74



ACCOUNT NO. 91221150    INVOICE NO. 1591747    INVOICE DATE 12/20/24    CUSTOMER NO. 11221140    PURCHASE ORDER NUMBER    SALES LOC. 3055    SALES REP. 0832    DATE ORDERED 12/19/24

Route: 5332 / 4

ORDER NUMBER: 987193

Bill

To:

SD VILLAGE COMM DEV DISTR  
3989 EAGLE LANDING PKWY  
  
ORANGE PARK FL  
32065

Ship

To:

TRN EAGLE LANDING GLF CLB  
3989 EAGLE LANDING PKWY  
  
ORANGE PARK FL  
32065  
904 291 5600  
DEPT # 00

Remit

To:

US Foods, Inc.  
P.O. BOX 198421  
  
ATLANTA GA  
30384-8421  
386 763 1304

Att: CHRIS COLLETTI

Ship From: 5425 S. WILLIAMSON BLVD PORT ORANGE FL Ship Date: 12/20/24 Page 01 of 02  
 Terms: NET 21 DAYS Special Instr: DRIVER MUST LEAVE FINAL RECEIPT FOR INV CHANGES  
 Qty Sales Product Description Pack Size Label C Weight Pricing Unit Price Extended Price  
 dered Shipped Unit Number

1	1	CS	2292472	DRY JUICE, APPL 100% PLST BTL SHLF24/10 BZ	TROPICANA			CS	23.4800	\$	23.48
---	---	----	---------	--	-----------	--	--	----	---------	----	-------

STORAGE LOCATION RECAP(N)

TOTAL DRY	PIECES ORDERED:	1	PIECES SHIPPED:	1	ITEMS SHIPPED:	1	23.48
-----------	-----------------	---	-----------------	---	----------------	---	-------

TOTAL NET WGT:	15.00	*** INVOICE SUMMARY ***	PIECES ORDERED:	1	PIECES SHIPPED:	1	ITEMS SHIPPED:	1
TOTAL GROSS WGT:	18.40							

PRODUCT TOTAL \$ 23.48

TAXABLE AMOUNT \$ .00  
 GEN SALES TAX % .00

This amount is an estimate at time of shipping prior to any adjustments made at delivery: \$ 23.48

*[Handwritten Signature]*  
12/23/24

000  
240-1340 = 23.48



ACCOUNT INVOICE INVOICE CUSTOMER PURCHASE ORDER  
 NO. NO. DATE NO. NUMBER  
 91221150 1591748 12/20/24 11221140

SALES SALES DATE  
 LOC. REP. ORDERED  
 3055 0832 12/19/24

Route: 5332 / 4

ORDER NUMBER: 987700

Bill To: SO VILLAGE COMM DEV DISTR  
 3989 EAGLE LANDING PKWY  
 ORANGE PARK FL  
 32065  
 Att: CHRIS COLLETTI

Ship To: TRN EAGLE LANDING GLF CLB  
 3989 EAGLE LANDING PKWY  
 ORANGE PARK FL  
 32065  
 904 291 5600  
 DEPT # 00

Remit To: US Foods, Inc.  
 P.O. BOX 198421  
 ATLANTA GA  
 30384-8421  
 386 763 1304

ipFrm: 5425 S. WILLIAMSON BLVD PORT ORANGE FL

ShipD: 12/20/24

Page 01 of 02

tTrms: DRIVER MUST LEAVE FINAL RECEIPT FOR INV CHANGES

tTrms: NET 21 DAYS

Qty	Sales Unit	Product Number	Description	Pack Size	Label	C D	Weight	Pricing Unit	Unit Price	Extended Price
-----	------------	----------------	-------------	-----------	-------	-----	--------	--------------	------------	----------------

1	1	CS 4207247	REFRIGERATED CORNED BEEF, SLCD CKD REF .66 6/2 LB HORMEL READY TO EAT - Please Refer to Return Policy					CS	107.9900	\$ 107.99
---	---	------------	---	--	--	--	--	----	----------	-----------

STORAGE LOCATION RECAP(N)

TOTAL REFRIGERATED      PIECES ORDERED: 1      PIECES SHIPPED: 1      ITEMS SHIPPED: 1      107.99

TOTAL NET WGT: 12.00      \*\*\* INVOICE SUMMARY \*\*\*  
 TOTAL GROSS WGT: 13.00      PIECES ORDERED: 1      PIECES SHIPPED: 1      ITEMS SHIPPED: 1

PRODUCT TOTAL \$ 107.99

TAXABLE AMOUNT \$ .00  
 GEN SALES TAX % .00

This amount is an estimate at time of shipping prior to any adjustments made at delivery: \$ 107.99

*[Handwritten Signature]*  
 12/23/24

000  
 240-1340=107.99

ACCOUNT INVOICE INVOICE CUSTOMER PURCHASE ORDER  
 NO. NO. DATE NO. NUMBER  
 91221150 1718296 12/24/24 11221140

SALES SALES DATE  
 LOC. REP. ORDERED  
 3055 0832 12/22/24

ORDER NUMBER: 992552

Bill

To:

50 VILLAGE COMM DEV DISTR  
 3989 EAGLE LANDING PKWY  
 ORANGE PARK FL  
 32065

Ship

To:

TRN EAGLE LANDING GLF CLD  
 3989 EAGLE LANDING PKWY  
 ORANGE PARK FL  
 32065  
 904 291 5600  
 DEPT # 00

Remit

To:

US Foods, Inc  
 P O. BOX 198421  
 ATLANTA GA  
 30384-8421  
 386 763 1304

Att:

CHRIS COLLETTI

igFrom: 5425 S. WILLIAMSON BLVD PORT ORANGE FL

ShipD: 12/24/24  
 Special  
 Instr:

DRIVER MUST LEAVE FINAL RECEIPT FOR INV CHANGE

Page 03 of 04

Terms: NET 21 DAYS

Qty Sales Product  
 dered Shipped Unit Number Description

Pack Size

Label

C

Weight

Pricing Unit

Unit Price

Extended Price

TOTAL NET WGT: 1161.67  
 TOTAL GROSS WGT: 1269.47

\*\*\* INVOICE SUMMARY \*\*\*

PIECES ORDERED: 62 PIECES SHIPPED: 62 ITEMS SHIPPED: 50

PRODUCT TOTAL \$ 2809.97

TAXABLE AMOUNT \$ .00  
 GEN SALES TAX 2 .00

This amount is an estimate at time of shipping prior to any adjustments made at delivery: \$ 2809.97

\*\*\*\*\*  
 \* You agree with respect to any dispute arising out of your purchase from  
 \* US Foods: (i) you are giving up your right to serve in any representative  
 \* capacity, or to participate as a member of a class, in any lawsuit; (ii) you  
 \* also agree, at US Foods sole option, to submit to binding, individual  
 \* arbitration of all claims; (iii) such arbitration shall be governed by the  
 \* Federal Arbitration Act, 9 U.S.C. s.1 and conducted in accordance with the  
 \* Commercial Rules of the American Arbitration Association; and (iv) each party  
 \* shall pay half the costs of arbitration, and separately pay its own attorneys'  
 \* fees and costs. For more information about the fuel surcharge, go to:  
 \* https://www.usfoods.com/terms/fuelsurcharge/StandardGridEIAAreaLowerAtlantic h  
 \* tml  
 \* If you have an agreement with US Foods that expressly addresses the  
 \* calculation of the fuel surcharge, please refer to that agreement.  
 \*\*\*\*\*

*[Handwritten signature]*  
 12/31/24

000  
~~240-1340 = 2568.98~~  
 240-7450 = 220.76  
 240-7444 = 20.23

Total = 2809.97

ACCOUNT INVOICE INVOICE CUSTOMER PURCHASE ORDER SALES SALES DATE  
 NO. NO. DATE NO NUMBER LOC. REP. ORDERED  
 91221150 1718296 12/24/24 11221140 3055 0832 12/22/24

Route: 2325 / 8

ORDER NUMBER: 992552

Bill To: 80 VILLAGE COMM DEV DISTR  
 3989 EAGLE LANDING PKWY  
 ORANGE PARK FL 32065  
 Att: CHRIS COLLETTI

Ship To: TRN EAGLE LANDING CLF CLB  
 3989 EAGLE LANDING PKWY  
 ORANGE PARK FL 32065  
 904 291 5600  
 DEPT # 00

Remit To: US Foods, Inc  
 P O BOX 198421  
 ATLANTA GA 30384-8421  
 386 763 1304

Ship From: 5425 S. WILLIAMSON BLVD PORT ORANGE FL Ship To: 12/24/24 Special Instr: DRIVER MUST LEAVE FINAL RECEIPT FOR INV CHANGES  
 Page 01 of 04

Net 21 DAYS  
 Qty Shipped Sales Unit Product Description Pack Size Label C Weight Pricing Unit Price Extended Price

Order No.	Product Description	Pack Size	Label	C	Weight	Pricing	Unit Price	Extended Price
	<b>DRY</b>							
1	CS 0698688 OIL, BUTR ALTRN SOYBN SALTD	3/1 GA	MONARCH			CS	34.7000	34.70
1	CS 0719427 LID, CUP 12-20 Z PLST WHT SLOT	10/100 EA	MONOGRAM			CS	27.3900	27.39
1	CS 0763326 CUP, FM 20 Z WHT	25/20 EA	MONOGRAM			CS	30.6700	30.67
1	CS 1017425 SALSA, THCK & CHNKY MILD SHLF	4/138 OZ	FAGE			CS	58.6000	58.60
1	CS 1859297 DRINK, SODA DR PPR CAN	24/12 OZ	DR PEPPER			CS	16.0300	16.03
1	CS 2101574 TOWEL, PAPER 12.7X10.1 C FLD	10/240 EA	PACBLU BSC			CS	37.5000	37.50
1	CS 2204360 DRINK, FRT PNCH PLST BTL WIDE	24/20 OZ	GATORADE			CS	23.9800	23.98
1	CS 3554565 DRINK, SODA COLA COKE CLSC CAN	24/12 OZ	COKE			CS	18.2900	18.29
1	CS 3554755 DRINK, SODA LNM LIME SPRTE CAN	24/12 OZ	SPRITE			CS	18.2900	18.29
2	CS 5851351 GLOVE, VINYL XL PF CLR ANBDX	10/100 EA	VALUGARDE			CS	21.6300	43.26
1	CS 6204366 DRINK, DRNG PLST BTL WIDE	24/20 OZ	GATORADE			CS	23.9800	23.98
1	CS 6617419 CONTAINER, FM 9.12X9 1 CMPT	150 EA	MONOGRAM			CS	29.0000	29.00
1	CS 6696848 BLEACH, DISINF LIQ JUG CLR	6/1 GA	MONOGRAM			CS	20.2300	20.23
1	CS 7013329 COFFEE, GRND BLU FRCT PK CFNTD	192/2 OZ	MAXWELL HS			CS	233.2400	233.24
1	CS 7466014 JUICE, PNAPL 100% BAR PK PLST	12/32 OZ	OCEANSPRAY			CS	23.4700	23.47
1	CS 7802523 NAPKIN, DMNR WHT 17X17 1 PLY	20/250 EA	VALU PLUS			CS	53.9400	53.94
2	EA 8003956 SAUCE, TYKI GLAZ PLST JUG SHLFS LB		KIKKOMAN	B		EA	8.9600	17.92
1	CS 8204505 DRINK, RSP BLU COOL PLST BTL	24/20 OZ	GATORADE			CS	23.9800	23.98
1	CS 9189275 MAYONNAISE, HVY PLST SHLF	4/1 GA	DUKE'S			CS	82.8000	82.80
	<b>REFRIGERATED</b>							
1	CS 0827428 EGG, HARD CKD PLD WHL REF DRY	12/1 DZ	BLNVW FRMS			CS	29.8800	29.88
1	CS 1022701 CHEESE, NTRY JK CHEDR BLND FCY4/5 LR		GRT LAKES			CS	73.9100	73.91
1	CS 2331353 TOMATO, RND SX6 #1 GRD FRESH	25 LB	CROSS VALY			CS	60.6100	60.61
1	EA 2348936 CARROT, STICK 3 3/4" FRESH	5 LB	CROSS VALY	B		EA	8.9400	8.94
3	CS 2721173 CHICKEN, WING 1R2JT JMB RAW	4/10 LB	PATUXEM1			CS	94.1200	282.36
1	CS 4284530 PEPPER, BELL RED CHD FRESH REFS LB		PACKER			CS	16.0100	16.01
1	CS 4667994 LIME, #1 GRD 48 CT REF 200 SZ 48 EA		CROSS VALY			CS	18.2600	18.26
4	CS 5327275 BEEF, PTY GRND 80/20 2:1 RND	20/8 OZ	CTLMN SLCT			CS	42.6500	170.64
1	CS 5332546 PICKLE, DILL KO CC CHIP	5 GA	MONARCH			CS	44.9200	44.92
1	CS 5394721 BACON, PORK REAL DCD 5" SMOKE	2/5 LB	HORNEL			CS	71.1700	71.17
1	CS 6419501 CHEESE, CHEDR MILD SLCD 75 Z	6/1.5 LB	BLNVW FRMS			CS	28.8700	28.87
1	EA 6712376 CANDY, SNCKR BAR SS IW REF Z	1.86 OZ	SNICKERS	B		EA	50.2900	50.29

Handwritten notes in the left margin:

- 10/11/24
- 10/12/24
- 10/13/24
- 10/14/24
- 10/15/24
- 10/16/24
- 10/17/24
- 10/18/24
- 10/19/24
- 10/20/24
- 10/21/24
- 10/22/24
- 10/23/24
- 10/24/24
- 10/25/24
- 10/26/24
- 10/27/24
- 10/28/24
- 10/29/24
- 10/30/24
- 10/31/24
- 11/1/24
- 11/2/24
- 11/3/24
- 11/4/24
- 11/5/24
- 11/6/24
- 11/7/24
- 11/8/24
- 11/9/24
- 11/10/24
- 11/11/24
- 11/12/24
- 11/13/24
- 11/14/24
- 11/15/24
- 11/16/24
- 11/17/24
- 11/18/24
- 11/19/24
- 11/20/24
- 11/21/24
- 11/22/24
- 11/23/24
- 11/24/24
- 11/25/24
- 11/26/24
- 11/27/24
- 11/28/24
- 11/29/24
- 11/30/24
- 12/1/24
- 12/2/24
- 12/3/24
- 12/4/24
- 12/5/24
- 12/6/24
- 12/7/24
- 12/8/24
- 12/9/24
- 12/10/24
- 12/11/24
- 12/12/24
- 12/13/24
- 12/14/24
- 12/15/24
- 12/16/24
- 12/17/24
- 12/18/24
- 12/19/24
- 12/20/24
- 12/21/24
- 12/22/24
- 12/23/24
- 12/24/24
- 12/25/24
- 12/26/24
- 12/27/24
- 12/28/24
- 12/29/24
- 12/30/24
- 12/31/24

Handwritten note: *check*

ACCOUNT NO. 91221150  
 INVOICE NO. 1718296

INVOICE DATE 12/24/24  
 CUSTOMER NO. 11221140

PURCHASE ORDER NUMBER

SALES LOC. 3055  
 SALES REP. 0832  
 DATE ORDERED 12/22/24

Route: 2325 / 8

ORDER NUMBER: 972552

**Bill To:**  
 80 VILLAGE COMM DEV DISTR  
 3989 EAGLE LANDING PKWY  
 ORANGE PARK FL 32065  
 Att: CHRIS COLLETTI

**Ship To:**  
 TRN EAGLE LANDING GLF CLB  
 3989 EAGLE LANDING PKWY  
 ORANGE PARK FL 32065  
 904 291 5600  
 DEPT # 00

**Remit To:**  
 US Foods, Inc.  
 P O BOX 198421  
 ATLANTA GA 30384-8421  
 404 743 1304

Ship From: 5425 S. WILLIAMSON BLVD PORT ORANGE FL

FL Ship Date: 12/24/24  
 Special Instr: DRIVER MUST LEAVE FINAL RECEIPT FOR INV CHANGE!

Page 02 of 04

Terms: NET 21 DAYS

Qty	Order	Qty	Sales Unit	Product Number	Description	Pack Size	Label	Weight	Pricing Unit	Unit Price	Extended Price
1	EA	1	EA	7331614	CELERY, STICK 4" FRESH REF	4/5 LB	CROSS VALY		EA	10.8300	10.83
1	CS	1	CS	9124520	DRESSING, RANCH HMSTY PLST JAR4/1 GA		KEN'S		CS	46.0800	46.08
1	CS	1	CS	9195249	DRESSING, HONY MUST DJON PLST 4/1 GA		KEN'S		CS	56.1100	56.11
1	CS	1	CS	0488239	FROZEN ROLL, HOGI WHT 8" SLCD BKD FZNS4/3.7 OZ		COSTANZO		CS	31.0200	31.02
1	CS	1	CS	1475608	BREAD, FLAT 5X13" OVAL BKD FZN36/3.61 OZ		STONEFIRE		CS	26.2900	26.29
1	CS	1	CS	2698743	SOUP, CHX DMPLG CNDSD ADD 3/4 LB		HOLLYS KIT		CS	43.2800	43.28
1	CS	1	CS	2122328	BEEF, STK T8D TP CC 1184B 6OZA24/6 OZA		STUCK YRDS	8.96 LB	LB	11.4200	102.32
1	CS	1	CS	2880300	POTATO, SLCD 1/10" SKON RAW 6/5 LB		MONARCH		CS	56.7100	56.71
5	CS	5	CS	2883130	POTATO, FF SC 3/8" EXTRA CRSPY6/5 LB		MONARCH		CS	50.1300	250.65
1	CS	1	CS	3200145	SALMON, ATLNTC 6 Z PTN PBO 3D 10 LB		HARBOR BNK		CS	100.1900	100.19
1	CS	1	CS	3330099	HOT DOG, AB 6:1 6" RLR GRIL 10 LB		FATUXENT		CS	31.3500	31.35
1	CS	1	CS	4165486	PRETZEL, SOFT STICK PLN 2.4 Z 72/2.4 OZ		BYRIANBKKY		CS	41.5600	41.56
1	CS	1	CS	4358495	BACON, PORK 18-22C SLC LAID 2015 LB		FATUXENT		CS	62.4300	62.43
1	CS	1	CS	5366760	BREAD, WHT 12.5" 21 SLCD 9/16" 6/28.32 OZ		ROTELLA		CS	26.2500	26.25
1	CS	1	CS	5736574	POTATO, FF SMT 3/16" X3/8" SC 5/3 LB		SWEETTRING		CS	40.6700	40.67
1	CS	1	CS	5915319	APPETIZER, CHS MOZZ BRDD 6/2 LB		LAMB WESTN		CS	64.9800	64.98
2	CS	2	CS	6553758	ROLL, KSR WHT 4.5" SLCD BKD 6/8/3.5 OZ		ROTELLA		CS	31.8100	63.62
1	CS	1	CS	7143605	RICE, VGTN FRIED CKD ROIL IN 4/3 LB		MINN		CS	39.5000	39.50
1	CS	1	CS	8117129	TURKEY, BRST SLICED 5 OZ 12/1 LB		JENNIE-O		CS	43.8000	43.80

STORAGE LOCATION RECAP(N)

TOTAL DRY	TOTAL REFRIGERATED	TOTAL FROZEN	PIECES ORDERED:	PIECES ORDERED:	PIECES ORDERED:	PIECES SHIPPED:	PIECES SHIPPED:	PIECES SHIPPED:	ITEMS SHIPPED:	ITEMS SHIPPED:	ITEMS SHIPPED:	PRICE
			21	20	21	21	20	21	19	15	16	1024.52

ACCOUNT INVOICE INVOICE CUSTOMER PURCHASE ORDER  
 NO. NO. DATE NO. NUMBER  
 91221150 1770576 12/27/24 11221140

SALES SALES DATE  
 LOC. REP. ORDERED  
 3055 0832 12/22/24

Route: 5207 / 10

ORDER NUMBER: 992609

Bill

To:

50 VILLAGE COMM DEV DISTR  
 3989 EAGLE LANDING PKWY

Ship

To:

TRN EAGLE LANDING GLF CLB  
 3989 EAGLE LANDING PKWY

Remit

To:

US Foods, Inc.

P.O. BOX 198421

ATLANTA

30384-8421

384 763 1304

GA

Att: CHRIS COLLETTI

Ship From: 5425 S. WILLIAMSON BLVD PORT ORANGE FL

Ship Date: 12/27/24

Page 02 of 03

Special Instr: DRIVER MUST LEAVE FINAL RECEIPT FOR INV CHANGE

Terms: NET 21 DAYS

Order	Qty	Sales	Product	Description	Pack Size	Label	C	Weight	Pricing	Unit	Extended
Number	Shipped	Unit	Number				D		Unit	Price	Price

1	1	CS	2122328	BEEF, STK T&D TP CC 1184R 60ZA24/6 OZA		STOCK YRDS		9.31	LB	11.4200	106.32
				CS: 0001 9.31 LBS							
4	4	CS	2883130	POTATO, FF SC 3/8" EXTRA CRSPY6/5 LB		MGNARCH			CS	50.1300	200.52
1	1	CS	3200145	SALMON, ATLNTC 6 Z PTN P80 3D 10 LB		HARBOR BNK			CS	100.1900	100.19
1	1	CS	4326880	MAHI MAHI, 6 Z PC BLSL RAW FZN10 LB		HARBOR BNK			CS	72.9500	72.95
1	1	CS	5915319	APPETIZER, CHS MOZZ BRDD 6/2 LB		LAMB WESTN			CS	64.9800	64.98
2	2	CS	6553758	ROLL, KSR WHT 4.5" SLCD BKD 6/8/3.5 OZ		ROTELLA			CS	31.8100	63.62
1	1	CS	6773501	TART, APPL RSTIC 4" SS BKD 3/8/6.3 OZ		CHEFS LINE			CS	52.0100	52.01
3	3	CS	7637713	CHICKEN, TNDLN BTRD FRITR BEER2/5 LB		PATUXENT			CS	39.9600	119.88
1	1	CS	9205147	BEEF, PTY GRND 75/25 3:1 HMSTY60/5.33 OZ		THTTSTYTM			CS	85.0000	85.00
1	1	CS	9870536	CHICKEN, BRST 3.5 Z BRDD HMSTY2/5 LB		TYSON REDL			CS	31.0100	31.01

STORAGE LOCATION RECAP(N)

TOTAL DRY	PIECES ORDERED:	11	PIECES SHIPPED:	11	ITEMS SHIPPED:	6	329.41
TOTAL REFRIGERATED	PIECES ORDERED:	22	PIECES SHIPPED:	22	ITEMS SHIPPED:	16	248.09
TOTAL FROZEN	PIECES ORDERED:	19	PIECES SHIPPED:	19	ITEMS SHIPPED:	13	578.02

TOTAL NET WGT:	899.42	*** INVOICE SUMMARY ***					
TOTAL GROSS WGT:	980.81	PIECES ORDERED:	52	PIECES SHIPPED:	52	ITEMS SHIPPED:	37

PRODUCT TOTAL \$ 2175.52

TAXABLE AMOUNT 00  
 GEN SALES TAX X 00

This amount is an estimate at time of shipping prior to any adjustments made at delivery: \$ 2175.52

000  
 246-1390 = 2093.09  
 240-7450 = 82.43  
 Total = 2175.52



ACCOUNT INVOICE INVOICE CUSTOMER PURCHASE ORDER  
 NO. NO. DATE NO. NUMBER  
 91221150 1770576 12/27/24 11221140

SALES SALES DATE  
 LOC. REP. ORDERED  
 3055 0832 12/22/24

Route: 5207 / 10

ORDER NUMBER: 992609

Bill To: 50 VILLAGE COMM DEV DISTR  
 3989 EAGLE LANDING PKWY  
 ORANGE PARK FL  
 32065  
 Attn: CHRIS COLLETTI

Ship To: TRN EAGLE LANDING GLF CLB  
 3989 EAGLE LANDING PKWY  
 ORANGE PARK FL  
 32065  
 904 291 5600  
 DEPT # 00

Remit To: US Foods, Inc.  
 P.O. BOX 198421  
 ATLANTA GA  
 30384-8421  
 336 763 1304

Ship From: 5425 S. WILLIAMSON BLVD PORT ORANGE FL Ship D: 12/27/24  
 Terms: NET 21 DAYS Special Instr: DRIVER MUST LEAVE FINAL RECEIPT FOR INV CHARGE  
 Page 01 of 03

Qty	Shipped	Sales Unit	Product Number	Description	Pack Size	Label	C Weight	Pricing Unit	Unit Price	Extended Price
DRY										
3	3	CS	1328699	SHORTENING, FRYG SOYBN LID CLR35 LB		HARVEST VL		CS	32.5600	97.68
1	1	CS	3112695	DRINK, SODA COLA DIET COKE CAN24/12 OZ		COKE		CS	18.2900	18.29
2	2	CS	3554565	DRINK, SODA COLA COKE CLSC CAN24/12 OZ		COKE		CS	18.2900	36.58
1	1	CS	5175377	SAUCE, RUFLO HOT RED PLST JUG 4/1 GA		FRANK'S		CS	35.2400	35.24
1	1	CS	5651351	GLOVE, VINYL XL PF CLR AMBDX 10/100 EA		VALUGARDS		CS	21.6300	21.63
1	1	EA	8002164	SAUCE, SOY PLST JUG SHLF STAB1 GA		KIKKOMAN	B	EA	12.2700	12.27
1	1	CS	8600645	CUP, PET PLST 12 Z CLD CLR 20/50 EA		DART		CS	60.8000	60.80
1	1	CS	9419292	ORANGE, MON WHL SGRT IN LS CND12/30 OZ		MONARCH		CS	46.9200	46.92
REFRIGERATED										
1	1	CS	0454210	PEPPER, BELL GREEN CHOICE FRESS LB		PACKER		CS	17.6900	17.69
1	1	CS	1919740	COLESLAW, SHRD SHORT SWT DIXIE2/4.5 LB		HOLLYS KIT		CS	18.4900	18.49
READY TO EAT - Please Refer to Return Policy										
1	1	CS	2264516	CUCUMBER, LARGE ENGLISH SEEDLE12 EA		PACKER		CS	19.7400	19.74
1	1	EA	2348936	CARROT, STICK 3 3/4" FRESH 5 LB		CROSS VALY	B	EA	8.9400	8.94
READY TO EAT - Please Refer to Return Policy										
1	1	CS	2679634	ZUCCHINI, GREEN #1 MEDIUM FRESS LB		PACKER		CS	10.7500	10.75
3	3	CS	2721173	CHICKEN, WING 1&2JT JMB RAW 4/10 LB		PATUXENT		CS	94.1200	282.36
2	2	CS	2725711	CHICKEN, BRST SNGL 6 Z BNLS 4/5 LB		PATUXENT		CS	68.0800	136.16
1	1	CS	3331998	BROCCOLI, FLORT MINI ICELS REF4/3 LB		CROSS VALY		CS	37.7300	37.73
READY TO EAT - Please Refer to Return Policy										
1	1	CS	4284530	PEPPER, BELL RED CHO FRESH REFS LB		PACKER		CS	16.0100	16.01
1	1	EA	4342010	CARROT, NTSTK SHRD FRESH REF 4/5 LB		CROSS VALY	B	EA	6.9600	6.96
READY TO EAT - Please Refer to Return Policy										
1	1	CS	4667994	LINE, #1 GRD 48 CT REF 200 SZ 48 EA		CROSS VALY		CS	18.2600	18.26
1	1	CS	5326418	LETTUCE, RMM FRESH REF 24 EA		CROSS VALY		CS	28.4600	28.46
4	4	CS	5327275	BEEF, PTY GRND 80/20 2:1 RND 20/8 OZ		OTLMN SLCT		CS	42.6600	170.64
1	1	CS	7060429	SOUR CREAM, CLTD ALL NTRL TUB 4/5 LB		DAISY		CS	30.9900	30.99
1	1	EA	7331614	CELERY, STICK 4" FRESH REF 4/5 LB		CROSS VALY	B	EA	10.8300	10.83
READY TO EAT - Please Refer to Return Policy										
1	1	CS	9124520	DRESSING, RANCH HMSTY PLST JAR4/1 GA		KEN'S		CS	46.0800	46.08
READY TO EAT - Please Refer to Return Policy										
FROZEN										
1	1	CS	0488239	ROLL, HOGI WHT 8" SLCD BKD FZNB/6/3.7 OZ		COSTANZO'S		CS	31.0200	31.02
1	1	CS	0766964	ICE CREAM, VNL PAPT TUB 3 GA		GLNHW FRMS		CS	24.9200	24.92
1	1	CS	1054265	BUN, HOT DOG WHT 6" SLCD CKD 8/12/1.7 OZ		HILLTOP HR		CS	25.6000	25.60



**ACUSHNET COMPANY**  
 P.O. BOX 965 FAIRHAVEN, MA 02719-0965  
 Tel: 800-225-8500 Fax: 508-979-3913



**INVOICE**  
 Currency: USD

Tax No: 04-2591836

<b>Invoice No</b> 819269478		<b>Invoice Date</b> 11/21/24	<b>Shipment Date</b> 11/21/24	<b>Order Date</b> 11/20/24
<b>Order No</b> 3025159398	<b>Whs</b> 05P	<b>Delivery No</b> 59966829	<b>Customer P.O.</b> TOURNAMENT EXCHANGE	<b>Account No</b> US00027669 \ US00040574

**Sold To**  
 SOUTH VILLAGE COMMUNITY DEVELOP  
 DISTRICT DBA EAGLE LANDING GOLF CLUB  
 3989 EAGLE LANDING PKWY  
 ORANGE PARK FL 32065-2641

**Ship To**  
 Charles Anderson  
 1019 PRAIRIE DUNES CT  
 ORANGE PARK FL 32065-2680

**Remit To**  
 Acushnet Company  
 P.O. Box 830334  
 Philadelphia, PA 19182-0334

**Payment Terms**  
 Net 60 Days  
**Payment Discount**  
 NA  
**Delivery Method**  
 FedEx Ground  
**Due Date**  
 01/20/25  
**Frnt Acct No**

Item No	Description	Shipped	U/M	Unit	Disc	Disc	Disc	Cstm	Net	Extended
54269 M100	DJ Prem Men WHT/NVY/BFG	1	PR	\$135.00	10%				\$121.50	\$121.50
54398 M100	Premiere Series MN WHT/WHT/NVY	1	PR	\$135.00	10%				\$121.50	\$121.50
<b>Total Shipped Qty.</b>		<b>2</b>								

<b>Net Order Total</b>	\$243.00
<b>Shipping and Handling Total</b>	\$11.27
<b>Total Invoice</b>	\$254.27

7430 - 100

**Effective December 1, 2024 Acushnet Golf will no longer mail invoice and statement documents.**  
 Please contact us at 800-225-8500 to set-up electronic delivery today.  
 You can access your account online at Acushnetgolf.com.

Invoices not paid within thirty (30) days of due date shall incur a service charge at the rate of the lesser of one and one-half percent (1.5%) per month or the highest rate permitted by law on any outstanding overdue balance from original due date.  
**SEE REVERSE SIDE FOR CONDITIONS OF SALE.**





**ACUSHNET COMPANY**  
 P.O. BOX 965 FAIRHAVEN, MA 02719-0965  
 Tel: 800-225-8500 Fax: 508-979-3913



**CREDIT NOTE**  
 Currency: USD

Tax No: 04-2591836

Invoice No 919275934		Invoice Date 11/22/24	Shipment Date 11/22/24	Order Date 11/22/24
Order No 3025168609	Whs 04B	Delivery No 1	Customer P.O. 3001468800	Account No US00027869 \ US00040574

**Sold To**  
 SOUTH VILLAGE COMMUNITY DEVELOP  
 DISTRICT DBA EAGLE LANDING GOLF CLUB  
 3989 EAGLE LANDING PKWY  
 ORANGE PARK FL 32065-2641

**Ship To**  
 EAGLE LANDING GOLF CLUB  
 ATTN PRO SHOP  
 3989 EAGLE LANDING PKWY  
 ORANGE PARK FL 32065-2641

**Remit To**  
 Acushnet Company  
 P.O. Box 844324  
 Boston, MA 02284-4324

**Payment Terms**  
 NA  
**Payment Discount**  
 NA  
**Delivery Method**  
 FedEx Ground  
**Due Date**  
 NA  
**Frnt Acct No**

Item No	Shipped	U/M	Unit	Disc	Disc	Cstm	Net	Extended
---------	---------	-----	------	------	------	------	-----	----------

Reference credit 300596397  
 Crediting restocking fees  
 Returned tournament shoes

FootJoy Restocking Fee -\$15.00

Net Order Total -\$15.00

CREDIT -\$15.00

7480-100

**Effective December 1, 2024 Acushnet Golf will no longer mail invoice and statement documents.**

Please contact us at 800-225-8500 to set-up electronic delivery today.  
 You can access your account online at [Acushnetgolf.com](http://Acushnetgolf.com).

Invoices not paid within thirty (30) days of due date shall incur a service charge at the rate of the lesser of one and one-half percent (1.5%) per month or the highest rate permitted by law on any outstanding overdue balance from original due date.  
**SEE REVERSE SIDE FOR CONDITIONS OF SALE.**

adidas  
 685 CEDAR CREST ROAD  
 SPARTANBURG, SC 29301  
 1-800-423-4327 (800-4-adidas)

INVOICE

~~10/13/25~~



2275-000 572.20  
 1325-000 .04

**B**  
**I**  
**L**  
**L**  
**T**  
**O**

SOUTH VILLAGE COMMUNITY DEV DIS  
 3989 EAGLE LANDING PKWY  
 ORANGE PARK FL 32065-2641  
 USA

**S**  
**H**  
**I**  
**P**  
**T**  
**O**

CUST NO. 30897001  
 EAGLE LANDING GOLF CLUB  
 3989 EAGLE LANDING PARKWAY  
 ORANGE PARK FL 32065  
 USA

adidas INVOICE NO.: 6162344153 CARRIER: FDEG DUNS: 95-985-3748  
 INVOICE DATE: 11/23/2024 CARTONS: 2 SALES PERSON: 020  
 adidas ORDER NO.: 73577068 WEIGHT: 60 LB ADDITIONAL REFERENCE:  
 TERMS: Net 60 days SOLD TO: 30897000  
 DUE DATE: 01/22/2025 NET AND PAST DUE THEREAFTER ORDER TYPE: Fill In Order  
 PRO#: CUSTOMER PURCHASE ORDER: DEC FOOTWEAR  
 INCOTERMS: EXW SP 6040  
 VICS BOL#: 429126579478

ORDERED QTY	SHIPPED QTY	BACKORDER QTY	MATERIAL NO. SIZE / QTY SHIPPED	DESCRIPTIONS	UNIT	LIST PRICE	UNIT PRICE	MERCHANDISE TOTAL USD		
1	7	7	IF0277	S2G SL 24 WD FTWWHT/FTWWH	PAA	60.00	55.20	386.40		
DELIVERY NOTE: 7248236926			9/1, 9-1, 10/1, 10-1, 11/1, 11-1, 12/1							
21	12	3	9	IG8105	S2G SL 24	PRLOIN/FTWWH	PAA	60.00	55.20	165.60
DELIVERY NOTE: 7248236926			9/1, 9-1, 13/1							

*[Handwritten Signature]*  
 12/2/24

Gross amount:	600.00
Total discount:	48.00-
SURCHARGE:	
FREIGHT:	20.24
TAX:	
Net Amount Due:	572.24

All claims must be submitted to adidas within thirty (30) days of the applicable invoice due date.  
 All Sales are subject to the General Terms and Conditions of Sale of adidas America, Inc.

No "payment in full" notation or other restrictive endorsement written on your payments will restrict our ability to collect all amounts owing to us.

Please support adidas sustainability journey by opting for e-payments via BILLER DIRECT or ACH.  
 ACH: adidas America, Inc. HSBC Bank, Buffalo, NY. Account No. 000250007. ABA: 022000020.

PLEASE REMIT TO: ADIDAS AMERICA INC.  
 DEPT CH 19361  
 PALATINE IL 60055-9361  
 USA

adidas  
 885 CEDAR CREST ROAD  
 SPARTANBURG, SC 29301  
 1-800-423-4327 (800-4-adidas)

# INVOICE



**B**  
**I**  
**L**  
**L**  
**T**  
**O**

SOUTH VILLAGE COMMUNITY DEV DIS  
 3989 EAGLE LANDING PKWY  
 ORANGE PARK FL 32065-2641  
 USA

**S**  
**H**  
**I**  
**P**  
**T**  
**O**

CUST NO. 30897001  
 EAGLE LANDING GOLF CLUB  
 3989 EAGLE LANDING PARKWAY  
 ORANGE PARK FL 32065  
 USA

adidas INVOICE NO.: 6162345098      CARRIER: FDEG      DUNS: 95-885-3748  
 INVOICE DATE: 11/24/2024      CARTONS: 1      SALES PERSON: 020  
 adidas ORDER NO.: 73577068      WEIGHT: 53 LB      ADDITIONAL REFERENCE:  
 TERMS: Net 60 days      SOLD TO: 30887000  
 DUE DATE: 01/23/2025 NET AND PAST DUE THEREAFTER      ORDER TYPE: Fill In Order  
 PRO#:      CUSTOMER PURCHASE ORDER: DEC FOOTWEAR  
 INCOTERMS: EXW SP 6040  
 VICS BOL#: 429126579456

ORDERED QTY	SHIPPED QTY	BACKORDER QTY	MATERIAL NO. SIZE / QTY SHIPPED	DESCRIPTIONS	UNIT	LIST PRICE	UNIT PRICE	MERCHANDISE TOTAL USD	
1	12	9	IG8105 S2G SL 24	PRLOINFTWWH	PAA	60.00	55.20	496.80	
DELIVERY NOTE: 7247114971			102, 10-2, 11/2, 11-2, 12/1						

*[Handwritten signatures and dates]*  
 12/24/24  
 1325 ~~100~~  
 2275-000 507.78  
 1325-000 (.02)

Gross amount:	540.00
Total discount:	43.20-
SURCHARGE:	
FREIGHT:	10.96
TAX:	
Net Amount Due:	507.76

All claims must be submitted to adidas within thirty (30) days of the applicable invoice due date.  
 All Sales are subject to the General Terms and Conditions of Sale of adidas America, Inc.

No "payment in full" notation or other restrictive endorsement written on your payments will restrict our ability to collect all amounts owing to us.

Please support adidas sustainability journey by opting for e-payments via BILLER DIRECT or ACH.  
 ACH: adidas America, Inc. HSBC Bank, Buffalo, NY. Account No. 000250007. ABA: 022000020.

PLEASE REMIT TO: ADIDAS AMERICA INC.  
 DEPT CH 19361  
 PALATINE IL 60055-8361  
 USA



REMIT PAYMENT TO:  
 CINTAS CORP  
 P.O. BOX 630910  
 CINCINNATI, OH 45263-0910

VIEW & PAY YOUR BILLS ONLINE:  
 WWW.CINTAS.COM/MYACCOUNT

CUSTOMER SVC/BILLING 833-290-0514  
 CINTAS FAX # 904-741-6116  
 PAYMENT INQUIRY 904-741-4525

INVOICE

SHIP TO: EAGLE LANDING GOLF CLUB  
 3989 EAGLE LANDING PKWY  
 ORANGE PARK, FL 32065-2641

INVOICE # 4217057434  
 INVOICE DATE 01/07/2025

BILL TO: EAGLE LANDING GOLF CLUB  
 3989 EAGLE LANDING PKWY  
 ORANGE PARK, FL 32065-2641

SOLD TO # 22390656  
 PAYER # 22385762  
 PAYMENT TERMS NET 10 EOM  
 SORT # 02800003369  
 CINTAS ROUTE 53 / DAY 2 / STDP 011

EMPL/LOCK#	MATERIAL	DESCRIPTION	FREQ	EXCH	QTY	UNIT PRICE	LINE	TOTAL	TAX
	X20023	SIG HROWND WNT LRG-	01	F	12	9.520	114	24	Y
	X2700	TERRY TOWEL - WHITE-	01	F	320	0.202	64	64	Y
	X2700	TERRY TOWEL - WHITE-	L 01	F	29	0.601	17	43	N
	X27026	SIG AIR SVC	01	F	21	3.867	81	21	Y
	X27097	SIG TRASHCAN DSP ALU-	01	F	24	1.190	28	56	Y
	X2873	BID APRON-BLACK-	01	F	60	0.444	26	64	Y
	X2873	BID APRON-BLACK-	L 01	F	1	9.261	9	26	N
	X6680	DISP URINAL MAT SVC	01	F	9	2.380	21	42	Y
	X9110	JRT TOILET TISSUE REFILL-	01	F	12	4.760	57	12	Y
	X9213	SANIS SCREEN SERVICE	01	F	9	2.380	21	42	Y

SUBTOTAL

SERVICE CHARGE

*MINEN - 86.30*  
 240.7445 - ~~103.92~~

SUBTOTAL  
 SALES TAX  
 TOTAL USD

240.7440 - 103.92  
 200.7440 - 36.00  
 400.7440 - 66.00  
 600.7440 - 34.00

TOTAL ADJUST.

TAX ADJUST.

NET TOTAL

441.94  
 7.00 Y  
 449.02  
 31.67  
 480.69

1460-000 -70.00  
 1470-000 70.00

*Rec'd Mt.  
 1/7/25 -*

*\$357.89  
 - Tax = 326.22*

Purchase Employee gifts or company swag through account.cintas.com and use code SHIPLAUNCH for 10% OFF your 1st online order of \$150 or more. \* Promotion ends 1/31/2025.

*Sent for tax for PAO  
 empty Do not tax  
 \$326.22  
 PAO  
 Amt*



Location : CINTAS FIRE PROTECTION

\*\*\* INVOICE CUSTOMER COPY \*\*\*

Invoice # : 0F61660449 Inv Date : 1/06/2025
Customer : 12622 Loc : F61
Type : CHG-S Route : 05
PO Number : Acct # : 12622
WO Number : Acct Zip : 32065
Service Visit : 10671609

Remit to:
CINTAS FIRE 636525
P.O. BOX 636525
CINCINNATI, OH 452636525
(904)562-7000

Bill to:
EAGLE LANDING
3975 EAGLE LANDING PKWY
SOUTH VILLAGE COMMUNITY
ORANGE PARK, FL 32065

Serviced:
EAGLE LANDING
3975 EAGLE LANDING PKWY
SOUTH VILLAGE COMM
ORANGE PARK, FL 32065

Table with 4 columns: Item, Qty, Description, Unit Price, Net Amount Tx. Rows include EELINK, EEROD, INKST, A439827, INKS, SC, and summary rows for SUB-TOTAL, TAX, and TOTAL.

CINTAS FIRE PROTECTION
#98454000012007
#98452300012007
#502087000199
EF20000872

Handwritten notes: 570-7600, 8, and a signature with date 1/7/25.



# Florida's of Golf First Coast

4300 Marsh Landing Blvd, Ste 102  
Jacksonville Beach, FL 32250

## Invoice

Date	Invoice #
1/6/2025	3181

Bill To
Eagle Landing Jim Hahn 3989 Eagle Landing Parkway Orange Park, FL 32065

Description		Due Date	Amount
FY 25 Golf Tourism Marketing Partnership Investment  Full integration into working FY 25 regional golf tourism marketing plan  Personalized landing page on FFCG website, SEO, Paid Media, Email marketing, social media, content development, promotional & editorial opportunities 4 of 12  <div style="text-align: center;"> <p>500-7230</p> <p>8</p> <p>APC</p> <p>1/7/25</p> </div>		1/6/2025	382.08
Thank you for your partnership.		<b>Total</b>	<b>\$382.08</b>
		<b>Payments/Credits</b>	<b>\$0.00</b>
		<b>Balance Due</b>	<b>\$382.08</b>

All invested funds will be spent in accordance with Florida's First Coast of Golf, Inc.'s Articles of Incorporation;  
Article III: Purpose and Article IV: Scope of Activity as a pooled marketing fund.  
To promote all golf related tourism in NEFL as a golf tourist destination.



Invoice

1 Heritage Dr.  
Quincy, MA 02171  
www.granitenet.com

Eagle Landing Golf Course  
3989 Eagle Landing Parkway  
Orange Park, FL 32065

4W-7835  
S.  
AA  
1/7/25

**Customer Service:**  
(866) 847-5500  
Email: [custserv@granitenet.com](mailto:custserv@granitenet.com)  
Contact our 24/7 Customer Service Team for any service issues, questions, or concerns.

You can now pay your bills online using our online portal. Log in and pay at [www.granitenet.com/billpay](http://www.granitenet.com/billpay)

**Written Correspondence to:**  
Granite Telecommunications, LLC  
1 Heritage Dr.  
Quincy, MA 02171

Account Information

ACCOUNT NUMBER: 04315239  
INVOICE DATE: 1/1/25

PAYMENT DUE UPON RECEIPT

Savings Summary

MONTHLY SAVINGS: \$0.00  
ANNUAL SAVINGS: \$0.00  
LIFETIME SAVINGS: \$0.00

Account Summary

PREVIOUS BALANCE DUE: \$92.63  
PAYMENTS RECEIVED THRU 1/01/25 \$92.63  
CURRENT CHARGES, TAXES, SURCHARGES: \$92.65  
ADJUSTMENTS: \$0.00

**TOTAL AMOUNT DUE: \$92.65**

PLEASE SEE FOLLOWING PAGE(S) FOR DETAILS

Special Message

Thank you for keeping your account current. For additional summary reports, please access your Rock Report Center at <https://rockreports.granitenet.com>. Please contact our Customer Service department with any issues or questions.

Attention: For information regarding the 2025 California Bill Inserts and Directory Page, please visit [Granitenet.com/legal](http://Granitenet.com/legal).

P A Y M E N T C O U P O N

- Make checks payable to Granite Telecommunications
- Please return this portion with your payment to ensure proper credit
- For address or phone changes please contact our 24/7 Customer Service Team.
- Please do not staple, tape, or glue payment to Payment Coupon.

YOUR ACCOUNT NUMBER: 04315239  
INVOICE NUMBER: 677291754  
INVOICE DATE: 1/1/25

Due Date Upon Receipt	
Amount Due	\$92.65
Amount Enclosed	.

Eagle Landing Golf Course  
3989 Eagle Landing Parkway  
Orange Park, FL 32065

Remit payment to: Granite Telecommunications LLC  
P.O. Box 830103  
Philadelphia, PA 19182-0103

0431523906772917540000092657





# INVOICE

PLEASE PAY FROM THIS INVOICE  
ORIGINAL

*400 - 7610  
1/1/25  
77*

INVOICE NO.
102926043
ORDER NO.
529835ZG
ACCOUNT NO.
087785

TERMS: 1% 10 DAYS  
NET 30 DAYS

LATE PAYMENT FEE  
OF 1-1/2% PER MONTH  
WHICH IS AN ANNUAL  
PERCENTAGE RATE  
OF 18% WILL BE  
ADDED ON ALL  
BALANCES 30 DAYS  
OLD

REMIT TO: KIMBALL MIDWEST  
DEPT. L-2780  
COLUMBUS, OHIO 43280-2780  
(614-219-6100)  
WWW.KIMBALLMIDWEST.COM

SOLD TO:  
EAGLE LANDING GOLF MAINTENANCE  
890 OAKLEAF PLANTATION PKWY  
  
ORANGE PARK FL 32065

SHIP TO:  
EAGLE LANDING GOLF MAINTENANCE  
890 OAKLEAF PLANTATION PKWY  
JON ROE  
ORANGE PARK FL 32065

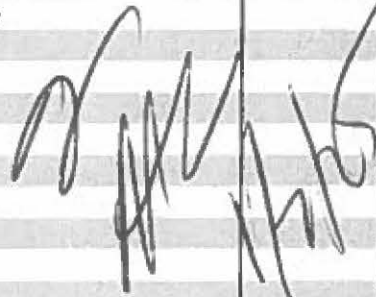
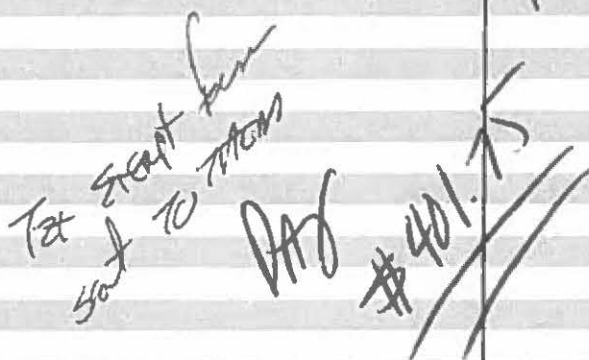
DATE	SALES REPRESENTATIVE	PURCHASE ORDER NO.	SHIPPED VIA & DATE		
12/30/2024	Oslin #5ZG		U UPS GROUND	12/30/2024	
ORDERED	SHIPPED	BALANCE DUE	DESCRIPTION	UNIT PRICE	AMOUNT
1	1		823537SS DRILL SET		315.00
1	1		52561 Coupler		45.85
10	10		831613SS MASK		40.90
UPS GROUND 1ZA913V50301343562 WGT:5.0					
To help us correctly process your payment, please include invoice number on your remittance advice					
Payment by credit card after time of invoice incurs an additional fee.					
					
<i>Tax credit form sent to them</i> 					
Thank you for your business! Payment is due by 01/29/2025					
Please mail by 01/22/2025					

You acknowledge and agree that, by placing this order, all information provided you by Kimball Midwest herein is confidential and is the property of Midwest Motor Supply Co., Inc. d/b/a Kimball Midwest. You further agree that this information is for your internal use only and will not be copied, reproduced, distributed or disclosed by you and/or your organization without the prior written consent from Kimball Midwest.

CARRIERS RECEIPT IN GOOD ORDER CONSTITUTES DELIVERY AND CLAIMS FOR LOSS OR DAMAGE IN TRANSIT MUST BE FILLED BY CUSTOMER.

GOODS RETURNED WITHOUT OUR CONSENT WILL POSITIVELY NOT BE ACCEPTED. DEBTOR IS LIABLE FOR UNUSUAL AND CUSTOMARY COLLECTION CHARGES. ALL CHECKS MUST BE MADE PAYABLE ONLY TO "KIMBALL MIDWEST"

ORDERED	TAX %	TAX AMT	SHIPPING	INVOICE TOTAL
401.75		<del>30.13</del>		431.88

**We Appreciate Your Business**

PLEASE REMIT THIS AMOUNT

*No tax*

*\$ 401.75*



PTE Golf, LLC  
 2017 Palmetto Pine Lane  
 Orlando FL 32828 US

# INVOICE

DATE 11/1/2024 DUE INVOICE # 214636

**BILL TO**  
 Eagle Landing Golf Club  
 ATTN: Golf Shop/Rob  
 3989 Eagle Landing Parkway  
 Orange Park FL 32065

**SHIP TO**  
 Eagle Landing Golf Club  
 ATTN: Golf Shop/Rob  
 3989 Eagle Landing Parkway  
 Orange Park FL 32065

DESCRIPTION	QTY	RATE	AMOUNT
<b>Vinyl Pack of 100 Sheets</b> Pack of 100 Vinyl Sheets for the PTE Golf Proximity Marker & Fairway Contest Marker.  Vinyl Sheet Type: Proxy Logo Color: Black Contest Text to Read: Closest to the Pin	5.00	75.00	375.00
<b>SHIPPING</b> Shipping and Handling Charges - UPS Ground *Ordered by Rob	1.00	24.97	24.97

7400-100  
  
  
 11/7/21

**399.97**

BALANCE 399.9700

**PAYMENT:** Please add a 4% credit card fee to the total if you prefer to pay by credit card. Please make all checks payable to "PTE Golf".

DELIVERY COPY

CONFIDENTIAL PROPERTY OF SYSCO

EAGLE LANDING GOLF CLUB  
3989 EAGLE LANDING PKWY  
ORANGE PARK FL 32065-2641



SYSCO JACKSONVILLE, INC.  
1501 LEWIS INDUSTRIAL DRIVE  
JACKSONVILLE, FL 32254  
1-800-797-2627 (1-800 SYSCO CS)

904-637-0648

EAGLE LANDING GOLF CLUB  
3989 EAGLE LANDING PKWY  
ORANGE PARK FL 32065 -2641

DELIV. DATE	CUSTOMER	INVOICE NUMBER	PAGE
12/21/24			
TRUCK STOP	784966	583014851	5 2
617/002			
ROUTE	PURCHASE ORDER		
6637	TERMS - PAST DUE BALANCES ARE SUBJECT TO SERVICE CHARGE		
	Net 30		
	MANIFEST# 1275231 NORMAL DELIVERY		
	MA: TVADC SCARLETT BAYLESS		

DRIVER:

LOC	QTY	PACK	SIZE	ITEM DESCRIPTION	ITEM CODE	UNIT PRICE	UNIT TAX AMOUNT	EXTENDED PRICE	INVOICE ADJUSTMENTS	
									CODE	QTY
D	1	CS	10060	GALSYS REL LINER REPRO 38X58 1.5 ML X7658AKSX01 GROUP TOTAL**** ***CHEMICAL & JANITORIAL***	1763846	41.77		41.77 90.35		
D	1	CS	125LB	KEYSTON DETERGENT LAUNDRY PWDR WHT R 6100197 ** HAZARD ** GROUP TOTAL**** ***PRODUCE***	8412142	45.59		45.59 45.59		
C	OUT	CS	148 CT	PACKER LIME FRESH OUT/STOCK 1	1079425					
C	1	CS	112 CT	IMPFRSH LIME FRESH SUBSTITUTE	7412570	8.39		8.39		
C	1S	ONLY5 LB		IMPFRSH MUSHROOM SLCD TUBS FRESH	6056907	15.75		15.75		
C	1S	ONLY10 LB		IMPFRSH ONION YELLOW JUMBO FRESH SACK	7201992	9.07		9.07		
C	1S	ONLY5 LB		IMPFRSH ORANGE BAGGED FRESH 10889356163020 GROUP TOTAL**** ***DISPENSER BEVERAGE***	7289526	9.24		9.24 42.45		
D	1	CS	15 GAL	COCACOL SYRUP COKE ZERO SUGAR 5X1 B 37150010	5006448	105.40		105.40		
D	1	CS	12.5GAL	SEAGRAM SYRUP GINGER ALE 5X1 BIB 52400298	1978586	54.95		54.95		
D	1	BX	324 OZ	LUZIANN TEA BREW FILTER PACK 47900-30384 GROUP TOTAL****	6738173	52.89		52.89 213.24		
	MISC CHARGES							6.54		
	ORDER SUMMARY							8.00		
	: 2740550 2738924 2740504 2740510									

000  
240-1340 = 724.17  
240-7450 = 90.35  
Total = 814.52

*[Handwritten signature]*  
12/23/24

CASES	SPLIT	TOT. PCS	CUBE	GROSS WT.	OPEN: 7:00 AM	CLOSE: 5:00 PM	REMIT TO	
6	3	9	4.6	155			SYSCO JACKSONVILLE	
18	4	22	22.9	454			1501 LEWIS INDUSTRIAL DR	SUB TOTAL 814.52
							JACKSONVILLE, FL 32254	TAX TOTAL
DRIVER'S SIGN	NO. PCS DELVD.	CUST. SIGNED INVOICE EVIDENCE OF ALL ITEMS SIGN	NO. PCS REC.					INVOICE TOTAL 814.52

IMPORTANT FACA PROVISION: THE PERISHABLE AGRICULTURAL COMMODITIES LISTED ON THIS INVOICE ARE SUBJECT TO THE STATUTORY TRUST NOTIFICATION BY SECTION 5 (C) OF THE PERISHABLE AGRICULTURAL COMMODITIES ACT 1930 (U.S.C. 495(C)). THE SELLER OF THIS COMMODITY RETAINS A TRUST CLAIM OVER THESE COMMODITIES, ALL INVENTORIES OF FOOD OR OTHER PRODUCTS DERIVED FROM THESE COMMODITIES, AND ANY RECEIVABLES OR PROCEEDS FROM THE SALE OF THESE COMMODITIES UNTIL FULL PAYMENT IS RECEIVED. FURTHER, YOU AGREE WITH RESPECT TO ANY DISPUTE ARISING OUT OF YOUR RECEIPT OF THESE PRODUCTS/SERVICES: YOU ARE GIVING UP YOUR RIGHT TO SERVE IN ANY REPRESENTATIVE CAPACITY OR TO PARTICIPATE AS A MEMBER OF A CLASS OF CLAIMANTS IN ANY LITIGATION INVOLVING ANY SUCH INVOICE.

PAYABLE ON OR BEFORE 1/20/25

LAST PAGE

EXCEL OPPORTUNITY AND AFFIRMATIVE ACTION CLAUSES OF 41 CFR 60-1.4, 60-250.4 AND 60-714.4 ARE INCORPORATED HEREIN BY REFERENCE

DELIVERY COPY

CONFIDENTIAL PROPERTY OF SYSCO

EAGLE LANDING GOLF CLUB  
3989 EAGLE LANDING PKWY  
ORANGE PARK FL 32065-2641



SYSCO JACKSONVILLE, INC.  
1501 LEWIS INDUSTRIAL DRIVE  
JACKSONVILLE, FL 32254  
1-800-797-2627 (1-800 SYSCO CS)

904-637-0648

EAGLE LANDING GOLF CLUB  
3989 EAGLE LANDING PKWY  
ORANGE PARK FL 32065 -2641

DELV. DATE	CUSTOMER	INVOICE NUMBER	PAGE	
12/21/24	784966	583014851	5	1
TRUCK STOP	617/002			
ROUTE	6637			
PURCHASE ORDER				
TERMS - PAST DUE BALANCES ARE SUBJECT TO SERVICE CHARGE				
Net 30				
MANIFEST# 1275231 NORMAL DELIVERY				
MA: TVADC SCARLETT BAYLESS				

DRIVER:

QTY	PACK	SIZE	ITEM DESCRIPTION	ITEM CODE	UNIT PRICE	UNIT TAX AMOUNT	EXTENDED PRICE	INVOICE ADJUSTMENTS	
							CODE	QTY	
FOOD SAFETY REMINDER: NOTHING IS MORE IMPORTANT TO SYSCO THAN DELIVERING SAFE PRODUCTS. PLEASE VERIFY EACH ORDER UPON RECEIPT BECAUSE COOLER ITEMS CANNOT BE RETURNED LATER. SALTWATER FISH LIC WD-4511 FRESHWATER FISH LIC FWD-303 SHELLFISH CERT NUMBER 182 SS									
***DAIRY***									
C	1SCS	65 LB	AREZIMP CHEESE MOZZARELLA LMPS SHRD	100721	9008335	78.82	78.82		
							78.82		
***MEATS***									
F	1 CS	325 OZ	CAB BEEF STEAK PHILLY CAB BR	10000001650	9789785	81.85	81.85		
							81.85		
***FROZEN***									
F	1 CS	82LB	TANTLER ONION RING BRD GOURM 5/8IN	30410	0916387	57.07	57.07		
F	1 CS	722.4 OZ	BAV BAK PRETZEL BAVARIAN STK	3295	6849145	38.89	38.89		
							95.96		
***CANNED & DRY***									
D	1 CS	2420 OZ	GATRADE DRINK FRUIT PUNCH G2	10052000204053	6508978	29.84	29.84		
D	1 CS	3614 OZ	HSRCIMP KETCHUP SQUEEZE RED BTL	HOUYA1R	4560934	49.57	49.57		
D	1S	ONLY1 GAL	CASACLS PEPPER JALAPENO SLICES	12730720211	8426330	12.17	12.17		
D	1 CS	2410 OZ	CAN DRY SODA GINGER ALE BTL	1690000301	4295861	22.60	22.60		
D	2 CS	4016.9OZ	NIAGARA WATER BOTTLED SPRING		9901031	13.73	27.46		
D	1 CS	612 CT	TAC MEX WRAP TORTILLA GRNC HERB 12	195210	8031852	23.16	23.16		
							164.80		
***PAPER & DISP***									
D	1 CS	1509X9X3	SYS CLS CONTAINER FOAM HNG 1C D YTD199S10000		7551334	21.02	21.02		
D	1 CS	2025 CT	DART CUP FOAM TALL 20 OZ	20J16	4088886	27.56	27.56		

CASES	SPLIT	TOT. PCS	CUYB	GROSS WT.	OPEN: 7:00 AM	CLOSE: 5:00 PM	REMIT TO			
12	1	13	18.3	299				SYSCO JACKSONVILLE		
							1501 LEWIS INDUSTRIAL DR	NET TOTAL	470.01	
							JACKSONVILLE, FL 32254	TAX		
DRIVER'S SIGN							NO. PCS DELVD.	CUST. SIGNED INVOICE EVIDENCE OF ALL ITEMS SIGN X	NO. PCS REC.	INVOICE TOTAL

IMPORTANT FACTS PROVIDED: THE PERISHABLE AGRICULTURAL COMMODITIES LISTED ON THIS INVOICE ARE SUBJECT TO THE STATUTORY TRUST AUTHORIZED BY SECTION 5 (C) OF THE PERISHABLE AGRICULTURAL COMMODITIES ACT 1930 (U.S.C. 492(C)). THE SELLER OF THIS COMMODITY RETAINS A TRUST CLAIM OVER THESE COMMODITIES. ALL INVENTORIES OF FOOD OR OTHER PRODUCTS DERIVED FROM THESE COMMODITIES, AND ANY RECEIVABLES OR PROCEEDS FROM THE SALE OF THESE COMMODITIES UNTIL FULL PAYMENT IS RECEIVED. FURTHER, YOU AGREE WITH RESPECT TO ANY DISPUTE ARISING OUT OF YOUR RECEIPT OF THESE PRODUCTS/SERVICES: YOU ARE GIVING UP YOUR RIGHT TO SERVE IN ANY REPRESENTATIVE CAPACITY OR TO PARTICIPATE AS A MEMBER OF A CLASS OF PLAINTIFFS IN ANY LITIGATION PERTAINING TO THIS INVOICE.

PAYABLE ON OR BEFORE

CONT. ON PAGE 2

EQUAL OPPORTUNITY AND AFFIRMATIVE ACTION CLAUSES OF 41 CFR 60-1.4, 60-250.4 AND 60-714.4 ARE INCORPORATED HEREIN BY REFERENCE



# Invoice

TableTop Linen Rental  
 898 Bellevue Ave.  
 support@tabletoplinen.com  
 Daytona Beach, FL 32114 (386)254-3158

EAGLE LANDING GOLF CLUB  
 3989 Eagle Landing Parkway  
 Orange Park, FL 32065 (904)860-7177

Date	Invoice	Day	Garment Mark	Freq.	Seq	Term	Account	Route
01/01/2025	0133916	Wed		7	30	CHG	1193-00000	7

Line	Item	Empl	Name / Description	Sizes	Qty.	Min.	Adj. Qty.	Adj. Amt.	Unit Pr.	Ext. Price	OFFICE		ROUTE		Total
											Adj. Qty.	Adj. Amt.	Adj. Qty.	Adj. Amt.	
1	FBNPW		NAPKIN WHITE			200	0	\$0.00	\$0.1100	\$22.00	0	\$0.00	\$0.00	\$22.00	
2	FBNPW		NAPKIN WHITE			SRC	0	\$0.00	\$2.0000	\$4.00	0	\$0.00	\$0.00	\$4.00	
3	DGBAGST		BAG STAND				0	\$0.00	\$0.0100	\$0.02	0	\$0.00	\$0.00	\$0.02	
4	FB8585W		TC 85X85 WHITE			90	0	\$0.00	\$1.4700	\$132.30	0	\$0.00	\$0.00	\$132.30	
5	FBMESBAG		MESH BAG			10	0	\$0.00	\$0.0100	\$0.10	0	\$0.00	\$0.00	\$0.10	
6	DGCARTHAM		CART HAMPER				0	\$0.00	\$0.0100	\$0.01	0	\$0.00	\$0.00	\$0.01	
7	TPP		TOTAL PROTECTION PLAN					\$0.00		\$6.49		\$0.00	\$0.00	\$6.49	
			Delivery Charge					\$0.00		\$15.70		\$0.00	\$0.00	\$15.70	

Total Due	Cur. Bus.	Cur. Bal.	30	60	90	120	Office Adj.:	\$0.00	Subtotal:	\$180.62	Rte. Adj.:	\$0.00
\$581.04	\$193.68	\$387.36	\$0.00	\$0.00	\$0.00	\$0.00	Tax Adj.:	\$0.00	Sales Tax:	\$13.06	Tax Adj.:	\$0.00
Comment:							Net Adj.:	\$0.00	Prebill:	\$193.68	Net Adj.:	\$0.00

Total Adj.: \$0.00  
 Tax Adj.: \$0.00

Net Charge: **\$193.68**

*Handwritten:* ~~240-7465~~ LINEN  
 240-7465 LINEN

Received By: \_\_\_\_\_

*Handwritten signature:* [Signature]

*Handwritten note:* Tax credit commo

**Troon Golf LLC**

15044 N Scottsdale Road  
Suite 300  
Scottsdale, AZ 85254  
USA

**Invoice**



Page 1 of 1  
Invoice number ARINV-1010-175239  
Date 12/29/2024  
Project contract A00468  
Customer account 10221  
Payment terms  
Currency USD

A00468: Eagle Landing GC  
3989 Eagle Landing Parkway  
Orange Park, FL 32065  
USA

Category	Description	Employee	Date	Merchant	Original amount (FX)	Original currency	FX Rate	Amount
INDUSTRY INITIATIVES	2024 Industry Initiatives-Private/Semi Private (NCA, NGF, NGCOA, AGIC)				0.00		0.0000	445.00 USD
<b>Sub total</b>								<b>445.00 USD</b>
<b>Sales subtotal amount</b>	<b>Net amount</b>	<b>Sales or Withholding tax</b>						<b>Total</b>
445.00	445.00	0.00						445.00 USD

520-7150  
8  
APR  
1/7/25

**Remittance:**

Send electronic payment to:  
Account Name: Troon Golf LLC  
Bank: J/P Morgan, New York, NY 10081  
Account #: 689212314  
ABA/Routing #: 021000021 (for wire transfers)  
ABA/Routing #: 122100024 (for ACH transfers)



# VENDOR SHIP INVOICE

ACCOUNT NUMBER	INVOICE NUMBER	INVOICE DATE	CUSTOMER NUMBER	PURCHASE ORDER #	SALES LOCATION	SALES REP	DATE ORDERED
91221150	1329584	12/12/2024	11221140		3055	832	12/05/2024
FREIGHT TERMS	ORDER NUMBER	PAYMENT TERMS	ROUTE NUMBER	SPECIAL INSTRUCTIONS			
	953862	NET 21 DAYS	0	Attn: Foodservice Mgr./Kitchen			

<b>BILL TO</b>	<b>SHIP TO</b>	<b>REMIT TO</b>
SO VILLAGE COMM DEV DISTR 3989 EAGLE LANDING PKWY ORANGE PARK, FL 32065 ATTN: CHRIS COLLETTI (000) 000-0000	TRN EAGLE LANDING GLF CLB 3989 EAGLE LANDING PKWY ORANGE PARK, FL 32065 Dept.: 0 (904) 291-5600	US Foods, Inc. P.O. BOX 198421 ATLANTA, GA 30384-8421 (386) 763-1304

SHIPPED FROM: DRIVER NAME: ROUTE NUMBER: 0  
 SHIPPED DATE: 12/12/2024 DRIVER ID: STOP NUMBER: 0

INVOICE LINE DETAILS											
QUANTITY		SALES UNIT	PRODUCT NUMBER	DESCRIPTION	LABEL	PACK SIZE	CODE	WEIGHT	PRICING UNIT	UNIT PRICE	EXTENDED PRICE
ORD	SHIP										
FROZEN											
1	1	CS	5047986	CAKE, BALL TRUFL VNL SANTA .74 <i>Shipment Tracking: 4285 3560 5022, FEDEX</i> <i>Shipment Tracking: 4285 3560 5022, FEDEX</i>	RHLY DESVD	108/.74 OZ			CS	\$159.4200	\$159.42

STORAGE LOCATION RECAP(N)					
STORAGE LOCATION	TOTAL PIECES ORDERED	TOTAL PIECES SHIPPED	TOTAL ITEMS SHIPPED	TOTAL WEIGHT SHIPPED	TOTAL EXTENDED PRICE
FROZEN	1	1	1	5.06	\$159.42
<b>DELIVERY SUMMARY TOTALS</b>	<b>1</b>	<b>1</b>	<b>1</b>	<b>5.06</b>	<b>\$159.42</b>

### INVOICE SUMMARY

TOTAL NET WEIGHT SHIPPED	5.06	Product Total	\$159.42
TOTAL GROSS WEIGHT SHIPPED	7.06	Sales Tax	Rate: \$0.00
		PLEASE REMIT THIS AMOUNT BY	01/02/2025 <u>\$159.42</u>

*[Handwritten Signature]*  
 000  
~~244~~ - 1340 = 159.42





# VENDOR SHIP INVOICE

ACCOUNT NUMBER	INVOICE NUMBER	INVOICE DATE	CUSTOMER NUMBER	PURCHASE ORDER #	SALES LOCATION	SALES REP	DATE ORDERED
91221150	1487365	12/17/2024	11221140		3055	832	12/12/2024
FREIGHT TERMS	ORDER NUMBER	PAYMENT TERMS	ROUTE NUMBER	SPECIAL INSTRUCTIONS			
	970114	NET 21 DAYS	0	DRIVER MUST LEAVE FINAL RECEIPT FOR INV CHANGES			

<b>BILL TO</b>	<b>SHIP TO</b>	<b>REMIT TO</b>
SO VILLAGE COMM DEV DISTR 3989 EAGLE LANDING PKWY ORANGE PARK, FL 32065 ATTN: CHRIS COLLETTI (000) 000-0000	TRN EAGLE LANDING GLF CLB 3989 EAGLE LANDING PKWY ORANGE PARK, FL 32065 Dept: 0 (904) 291-5600	US Foods, Inc. P.O. BOX 198421 ATLANTA, GA 30384-8421 (386) 763-1304

**SHIPPED FROM:** DRIVER NAME: ROUTE NUMBER: 0  
**SHIPPED DATE:** 12/17/2024 DRIVER ID: STOP NUMBER: 0

INVOICE LINE DETAILS											
QUANTITY		SALES UNIT	PRODUCT NUMBER	DESCRIPTION	LABEL	PACK SIZE	CODE	WEIGHT	PRICING UNIT	UNIT PRICE	EXTENDED PRICE
ORD	SHP										
DRY											
1	1	CS	5941869	DRESSING, SESME GNDR SHLF PLST <i>Shipment Tracking: 427072088954, FEDEX</i> <i>Shipment Tracking: 427072088954, FEDEX</i>	CLGRESERVE	2/1 GA			CS	\$52.1300	\$52.13

STORAGE LOCATION RECAP(N)					
STORAGE LOCATION	TOTAL PIECES ORDERED	TOTAL PIECES SHIPPED	TOTAL ITEMS SHIPPED	TOTAL WEIGHT SHIPPED	TOTAL EXTENDED PRICE
DRY	1	1	1	18.65	\$52.13
<b>DELIVERY SUMMARY TOTALS</b>	<b>1</b>	<b>1</b>	<b>1</b>	<b>18.65</b>	<b>\$52.13</b>

### INVOICE SUMMARY

<b>TOTAL NET WEIGHT SHIPPED</b>	18.65	Product Total	\$52.13
<b>TOTAL GROSS WEIGHT SHIPPED</b>	19.65	Sales Tax	Rate: \$0.00
		<b>PLEASE REMIT THIS AMOUNT BY</b> 01/07/2025	<u>\$52.13</u>

000  
240-1340=52.13



# VENDOR SHIP INVOICE

ACCOUNT NUMBER	INVOICE NUMBER	INVOICE DATE	CUSTOMER NUMBER	PURCHASE ORDER #	SALES LOCATION	SALES REP	DATE ORDERED
91221150	1808450	12/27/2024	11221140		3055	832	12/22/2024
FREIGHT TERMS	ORDER NUMBER	PAYMENT TERMS	ROUTE NUMBER	SPECIAL INSTRUCTIONS			
	992729	NET 21 DAYS	0	DRIVER MUST LEAVE FINAL RECEIPT FOR INV CHANGES			

BILL TO	SHIP TO	REMIT TO
SO VILLAGE COMM DEV DISTR 3989 EAGLE LANDING PKWY ORANGE PARK, FL 32065 ATTN: CHRIS COLLETTI (000) 000-0000	TRN EAGLE LANDING GLF CLB 3989 EAGLE LANDING PKWY ORANGE PARK, FL 32065 Dept.: 0 (904) 291-5600	US Foods, Inc. P.O. BOX 198421 ATLANTA, GA 30384-8421 (396) 763-1304

**SHIPPED FROM:**  
 SHIPPED DATE: 12/27/2024

**DRIVER NAME:**  
 DRIVER ID:

**ROUTE NUMBER:** 0  
**STOP NUMBER:** 0

INVOICE LINE DETAILS											
QUANTITY		SALES UNIT	PRODUCT NUMBER	DESCRIPTION	LABEL	PACK SIZE	CODE	WEIGHT	PRICING UNIT	UNIT PRICE	EXTENDED PRICE
ORD	SHP										
DRY											
1	1	CS	2832327	SAUCE, HOT HABAN RED PLST JAR <i>Shipment Tracking: 434364104257, FEDEX</i> <i>Shipment Tracking: 434364104257, FEDEX</i>	ROLAND	4/32 OZ			CS	\$77.7400	\$77.74

STORAGE LOCATION RECAP(N)					
STORAGE LOCATION	TOTAL PIECES ORDERED	TOTAL PIECES SHIPPED	TOTAL ITEMS SHIPPED	TOTAL WEIGHT SHIPPED	TOTAL EXTENDED PRICE
DRY	1	1	1	8.00	\$77.74
<b>DELIVERY SUMMARY TOTALS</b>	<b>1</b>	<b>1</b>	<b>1</b>	<b>8.00</b>	<b>\$77.74</b>

### INVOICE SUMMARY

<b>TOTAL NET WEIGHT SHIPPED</b>	8.00	<b>Product Total</b>	\$77.74
<b>TOTAL GROSS WEIGHT SHIPPED</b>	10.00	<b>Sales Tax</b>	\$0.00
		<b>PLEASE REMIT THIS AMOUNT BY</b> 01/17/2025	<u>\$77.74</u>

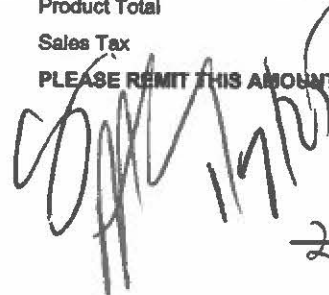
  
 000  
 240-1340 = 77.74

ACCOUNT INVOICE INVOICE CUSTOMER PURCHASE ORDER  
 NO. NO. DATE NO. NUMBER  
 91221150 1877264 12/31/24 11221140

SALES SALES DATE  
 LOC. REP. ORDERED  
 3055 0832 12/28/24

ORDER NUMBER: 5834

Bill

To:

50 VILLAGE COMM DEV DISTR  
 3989 EAGLE LANDING PKWY  
  
 ORANGE PARK FL  
 32065

Ship

To:

TRN EAGLE LANDING GLF CLB  
 3989 EAGLE LANDING PKWY  
  
 ORANGE PARK FL  
 32065  
 904 291 5600  
 DEPT # 00

Remit

To:

US Foods, Inc.  
 P.O. BOX 198421  
  
 ATLANTA GA  
 30384-8421  
 386 763 1304

Att: CHRIS COLLETTI

From: 5425 S. WILLIAMSON BLVD PORT ORANGE FL ShipD: 12/31/24 Page 01 of 02  
 Terms: NET 21 DAYS Special Instr: DRIVER MUST LEAVE FINAL RECEIPT FOR INV CHANGES

Qty	Sales	Product	Description	Pack Size	Label	C	Weight	Pricing	Unit	Extended
Shipped	Unit	Number				D		Unit	Price	Price

1	1	CS 18&5625	REFRIGERATED POTATO, RED B SZ REPAK FRESH	10 LB	CROSS VALY			CS	15.1900	\$ 15.19
---	---	------------	---	-------	------------	--	--	----	---------	----------

STORAGE LOCATION RECAP(N)

TOTAL REFRIGERATED	PIECES ORDERED:	1	PIECES SHIPPED:	1	ITEMS SHIPPED:	1	15.19
--------------------	-----------------	---	-----------------	---	----------------	---	-------

TOTAL NET WGT:	10.00	*** INVOICE SUMMARY ***	PIECES ORDERED:	1	PIECES SHIPPED:	1	ITEMS SHIPPED:	1
TOTAL GROSS WGT:	11.00							

PRODUCT TOTAL \$ 15.19

TAXABLE AMOUNT \$ 00  
 GEN SALES TAX 7 00

This amount is an estimate at time of shipping price to any adjustments made at delivery: \$ 15.19

000  
~~240~~-1340=15.19

ACCOUNT INVOICE INVOICE CUSTOMER PURCHASE ORDER  
 NO. NO. DATE NO. NUMBER  
 91221150 1877265 12/31/24 11221140

SALES SALES DATE  
 LOC. REP. ORDERED  
 3055 0832 12/29/24

Route: 2325 / 6

ORDER NUMBER: 7694

Bill To: 50 VILLAGE COMM DEV DISTR  
 3989 EAGLE LANDING PKWY  
 ORANGE PARK FL 32065  
 Attn: CHRIS COLLETTI

Ship To: TRN EAGLE LANDING GLF CLB  
 3989 EAGLE LANDING PKWY  
 ORANGE PARK FL 32065  
 904 291 5600  
 DEPT # 00

Remit To: US Foods, Inc.  
 P.O. BOX 198421  
 ATLANTA GA 30384-8421  
 386 753 1304

Ship From: 5425 S. WILLIAMSON BLVD PORT ORANGE FL Ship Date: 12/31/24 Page 04 of 04  
 Terms: Special DRIVER MUST LEAVE FINAL RECEIPT FOR INV CHANGE  
 Net Terms: NET 21 DAYS Instr:

Qty	Qty	Sales	Product	Description	Pack Size	Label	D	Weight	Pricing	Unit	Extended
Ordered	Shipped	Unit	Number						Unit	Price	Price

\*\*\*\*\*  
 \* You agree with respect to any dispute arising out of your purchase from \*  
 \* US Foods: (i) you are giving up your right to serve in any representative \*  
 \* capacity, or to participate as a member of a class, in any lawsuit; (ii) you \*  
 \* also agree, at US Foods sole option, to submit to binding, individual \*  
 \* arbitration of all claims; (iii) such arbitration shall be governed by the \*  
 \* Federal Arbitration Act, 9 U.S.C. s.1 and conducted in accordance with the \*  
 \* Commercial Rules of the American Arbitration Association; and (iv) each party \*  
 \* shall pay half the costs of arbitration, and separately pay its own attorneys' \*  
 \* fees and costs. For more information about the fuel surcharge, go to: \*  
 \* https://www.usfoods.com/terms/fuelsurcharge/StandardGridEIAAreaLowerAtlantic.n \*  
 \* tml \*  
 \* If you have an agreement with US Foods that expressly addresses the \*  
 \* calculation of the fuel surcharge, please refer to that agreement. \*  
 \*\*\*\*\*

\*\*\*\*\*  
 \* Cert. # FL 227-SS \*  
 \* Shellstock shipped in conveyance pre-chilled at / below 45F ambient air com \*  
 \* p. \*  
 \*\*\*\*\*

\*\*\*\*\*  
 \* USDA National Organic Program Indicators: \*  
 \* = 100% Organic \*  
 \* = Organic \*  
 \* = Made with organic ingredient(s) \*  
 \*\*\*\*\*

\*\*\*\*\*  
 \* The perishable agricultural commodities listed on this invoice are sold \*  
 \* subject to the statutory trust authorized by section 5(c) of the Perishable \*  
 \* Agricultural Commodities Act, 1930 (7 U.S.C 495e(c)). The seller of these \*  
 \* commodities retains a trust claim over these commodities, all inventories of \*  
 \* food or other products derived from these commodities, and any receivables or \*  
 \* proceeds from the sale of these commodities until full payment is received. \*  
 \*\*\*\*\*

Handwritten calculations:  
 $240-1340 = 3094.53$   
 $240-7444 = 176.25$   
 $500-7444 = 9.03$   
 $500-7450 = 212.94$   
 Total = 3492.75

ACCOUNT INVOICE INVOICE CUSTOMER PURCHASE ORDER  
 NO. NO. DATE NO. NUMBER  
 91221150 1877265 12/31/24 11221140

SALES SALES DATE  
 LOC. REP. ORDERED  
 3055 0632 12/29/24

Route: 2325 / 6

ORDER NUMBER: 7694

Bill

To:

50 VILLAGE COMM DEV DISTR  
 3989 EAGLE LANDING PKWY  
  
 ORANGE PARK FL  
 32065

Ship

To:

TRN EAGLE LANDING GLF CLB  
 3989 EAGLE LANDING PKWY  
  
 ORANGE PARK FL  
 32065  
 904 291 5600  
 DEPT # 00

Remit

To:

US Foods, Inc.  
 P.O. BOX 198421  
  
 ATLANTA GA  
 30384-8421  
 384 763 1304

Att: CHRIS COLLETTI

Ship From: 5425 S. WILLIAMSON BLVD PORT ORANGE FL

Ship Date: 12/31/24

Page 03 of 04

Terms: NET 21 DAYS Special Instr: DRIVER MUST LEAVE FINAL RECEIPT FOR INV CHARGES

Qty	Sales Unit	Product Number	Description	Pack Size	Label	C	Weight	Pricing Unit	Unit Price	Extended Price
-----	------------	----------------	-------------	-----------	-------	---	--------	--------------	------------	----------------

2	CS	6553758	ROLL, KSR WHT 4.5" SLCD BKD	6/8/3.5 OZ	ROTELLA			CS	31.8100	63.62
1	CS	7143605	RICE, VGTRN FRIED CKD BOIL IN	4/3 LB	MINN			CS	39.5000	39.50
1	CS	7637713	CHICKEN, TNDLN RTKD FRTR BEER	2/5 LB	PATUXENT			CS	39.9600	39.96
1	CS	8131864	BEEF, GRND 80/20 FINE RAW FZN	4/5 LB	AVENDRA			CS	86.0000	86.00
1	CS	8665119	BEEF, BRSKT WHL CHO CKD FZN	2/7 LBA	CHEFS LINE		16.20	LB	9.7900	158.60
			CS: 0001	16.20 LBS						

STORAGE LOCATION RECAP(N)

TOTAL DRY	PIECES ORDERED:	33	PIECES SHIPPED:	33	ITEMS SHIPPED:	31	1081.35
TOTAL REFRIGERATED	PIECES ORDERED:	24	PIECES SHIPPED:	24	ITEMS SHIPPED:	20	1038.03
TOTAL FROZEN	PIECES ORDERED:	24	PIECES SHIPPED:	24	ITEMS SHIPPED:	16	1372.37

\*\*\* INVOICE SUMMARY \*\*\*

TOTAL NET WGT:	1187.47	PIECES ORDERED:	81	PIECES SHIPPED:	81	ITEMS SHIPPED:	67
TOTAL GROSS WGT:	1315.80						

PRODUCT TOTAL \$ 3492.75

TAXABLE AMOUNT \$ .00  
 GEN SALES TAX % .00

This amount is an estimate at time of shipping prior to any adjustments made at delivery: \$ 3492.75



ACCOUNT INVOICE INVOICE CUSTOMER PURCHASE ORDER  
 NO. NO. DATE NO. NUMBER  
 91221150 1877265 12/31/24 11221140

SALES SALES DATE  
 LOC. REP ORDERED  
 3055 0832 12/29/24

Bill To: 50 VILLAGE COMM DEV DISTR  
 3989 EAGLE LANDING PKWY  
 ORANGE PARK FL  
 32065  
 Attn: CHRIS COLLETTI

Ship To: TRN EAGLE LANDING GLF CLB  
 3989 EAGLE LANDING PKWY  
 ORANGE PARK FL  
 32065  
 904 291 5600  
 DEPT # 00

Remit To: US Foods, Inc.  
 P.O. BOX 198421  
 ATLANTA GA  
 30384-8421  
 388 763 1304

Route: 2325 / 6

ORDER NUMBER: 7694

Orig From: 5425 S. WILLIAMSON BLVD PORT ORANGE FL Ship Date: 12/31/24 Page 01 of 04  
 Net Terms: Special Instr: DRIVER MUST LEAVE FINAL RECEIPT FOR INV CHANGE!

Qty	Order	Shipped	Qty	Sales Unit	Product Number	Description	Pack Size	Label	0	Weight	Pricing Unit	Unit Price	Extended Price
						DRY							
1			1	CS	0719427	LID, CUP 12-20 Z PLST WHT SLOT10/100 EA		MONOGRAM			CS	27.3900	27.39 ✓
1			1	CS	0763326	CUP, FM 20 Z WHT 25/20 EA		MONOGRAM			CS	30.6700	30.67 ✓
1			1	CS	1052380	MAYONNAISE, SS POUCH 500/12 GR		HEINZ			CS	47.2500	47.25
1			1	CS	1328659	SHORTENING, FRYG SOYBN LIQ CLR35 LB		HARVEST VL			CS	32.0100	32.01
1			1	CS	2008860	MUSTARD, YLW SS POUCH 500/.2 OZ		HEINZ			CS	15.6200	15.62
1			1	EA	2328706	DRESSING, ITLN GLDN SHLF STABL1 GA		HARVEST VL	H		EA	9.9500	9.95
1			1	EA	2330215	OIL, SESME IMP JPN TIN 1 GA		PACIFC JDE	B		EA	51.3600	51.36
1			1	CS	2833239	CHIP, ASST SS BAG SHLF STABL 2/30 EA		FRITO LAY			CS	41.0800	41.08
1			1	CS	3554565	DRINK, SODA COLA COKE CLSC CAN24/12 OZ		COKE			CS	19.2900	19.29
1			1	CS	3554649	DRINK, SODA DIET COKE ZERO 24/12 OZ		COKE ZERO			CS	19.2900	19.29
1			1	CS	3986002	PRESBAK, UTNSL D27 E-Z LIQ BTL5 LT		MONOGRAMCF			CS	72.2700	72.27
1			1	EA	4523510	CHERRY, MRCNO W/ STEM LG PLST .5 GA		MONARCH	B		EA	19.3900	19.39
1			1	CS	4800645	PECAN, PC LG UNSLTD CNDID SHL 5 LB		AZAR			CS	62.8000	62.80
1			1	CS	4959856	RINSE ADDITIVE, DSHWR D28 E-Z 5 LT		MONOGRAMCF			CS	103.9800	103.98
1			1	CS	5182720	BAR MIX, GRNDN PLST SHLF STABL12/1 LT		ROSE'S			CS	50.5000	50.50
1			1	CS	5204151	SAUCE, CHS NACHO SHLF STABL 6/#10 CN		ROSARITA			CS	89.1400	89.14
1			1	EA	5333711	OLIVE, GRN QUEEN STUFD W/ 1 GA		MONARCH	B		EA	26.3100	26.31
2			2	EA	5395967	SEASONING, LMN PPR SHLF STABL 28 OZ		MCCORMICK			EA	15.4300	15.43
2			2	CS	5488748	WATER, PRFID PLST BTL TWIST 24/16.9 OZ		THIRSTER			CS	4.7200	4.72
2			2	CS	5651351	GLOVE, VINYL XL PF CLR AMBX 10/100 EA		VALUGARIS			CS	21.6300	21.63
1			1	CS	6002398	KETCHUP, TMTD FCY 33% SS FBIL 1000/9 GR		HEINZ			CS	27.3000	27.30
1			1	CS	6617419	CONTAINER, FM 9.12X9 1 CMPT 150 EA		MONOGRAM			CS	26.0000	26.00
1			1	CS	6649289	SWEETENER, AGAVE NCTR SYRUP ? LT		MONIN			CS	39.1500	39.15
1			1	CS	6729776	KETCHUP, TMTD FCY 33% RED SQZ 16/14 OZ		HEINZ			CS	31.2100	31.21
1			1	CS	6823872	CRACKER, CHS PNT BUTR SNDWH SQ96/1.42 OZ		FLMUNCHIES			CS	22.8200	22.82
1			1	EA	7064199	SEASONING, CARIB JERK SHLF 18 OZ		MCCORMICK			EA	19.3600	19.36
1			1	CS	7802523	NAPKIN, DNMR WHT 17X17 1 FLY 20/250 EA		VALU PLUS			CS	53.9400	53.94
1			1	CS	8914897	STRAW, JMB 7.75" BLK WRFD CLR 10/500 EA		MONOGRAM			CS	29.6800	29.68
1			1	CS	9341223	CREAMER, HALF & HALF LIQ UHT 360/.3B OZ		GLNVW FRMS			CS	21.5700	21.57
1			1	CS	9395781	SCRUBBER, SYTHC FIBR 6X9 GRN 20 EA		NIAGARA			CS	9.0300	9.03
1			1	CS	9986647	PEANUT, HALF & PC RSTD SALTD 4/12/1.75 OZ		PLANTERS			CS	20.9200	20.92
						REFRIGERATED							
1			1	CS	0409516	STRAWBERRY, FRESH REF 4/1 LB		PACKER			CS	28.9400	28.94
1			1	CS	1022701	CHEESE, NTRY JK CHEDR BLND FCY4/5 LB		GRT LAKES			CS	73.9100	73.91
						READY TO EAT - Please Refer to Return Policy							
1			1	CS	2326411	LETTUCE, ICBRG FRESH REF BOX 24 EA		CROSS VALY			CS	33.2200	33.22

+++++

++

ACCOUNT NO. 91221150    INVOICE NO. 1877265    INVOICE DATE 12/31/24    CUSTOMER NO. 11221140    PURCHASE ORDER NUMBER    SALES LBC 3055    SALES REP. 0832    DATE ORDERED 12/29/24

Route: 2325 / 6    ORDER NUMBER: 7694

Bill To: 50 VILLAGE COMM DEV DISTR  
3989 EAGLE LANDING PKWY  
ORANGE PARK FL 32065  
Att: CHRIS COLLETTI

Ship To: TRN EAGLE LANDING GLF CLB  
3989 EAGLE LANDING PKWY  
ORANGE PARK FL 32065  
904 291 5600  
DEPT # 00

Remit To: US Foods, Inc.  
P.O. BOX 158421  
ATLANTA GA 30384-8421  
385 783 1304

Ship From: 5425 S. WILLIAMSON BLVD PORT ORANGE FL 32129    Ship Date: 12/31/24    Page 02 of 04  
Terms: NET 21 DAYS    Special Instr: DRIVER MUST LEAVE FINAL RECEIPT FOR INV CHANGES

Qty	Order	Shipped	Sales Unit	Product Number	Description	Pack Size	Label	C	Weight	Pricing Unit	Unit Price	Extended Price
1			CS	2331353	TOMATO, RND 5X6 #1 GRD FRESH	25 LB	CROSS VALY			CS	60.6100	60.61
1			EA	2348936	CARROT, STICK 3 3/4" FRESH	5 LB	CROSS VALY	B		EA	8.9400	8.94
					READY TO EAT - Please Refer to Return Policy							
3			CS	2721173	CHICKEN, WING 1&2JT JMB RAW	4/10 LB	FATUXENT			CS	94.1200	282.36
2			CS	2725711	CHICKEN, BRST SNGL 6 Z BNLS	4/5 LB	FATUXENT			CS	68.0800	136.16
1			CS	3011822	ONION, YLW JMB FRESH REF BOX	10 LB	CROSS VALY			CS	13.6500	13.65
1			CS	3331998	BROCCOLI, FLORT MINI ICELS REF	4/3 LB	CROSS VALY			CS	37.7300	37.73
					READY TO EAT - Please Refer to Return Policy							
1			CS	4207247	CORNEE BEEF, SLCD CKD REF .66	6/2 LB	HORMEL			CS	107.9900	107.99
					READY TO EAT - Please Refer to Return Policy							
1			CS	4284530	PEPPER, BELL RED CHO FRESH REFS	LB	PACKER			CS	16.0100	16.01
1			EA	4342010	CARROT, MTSTK SHRD FRESH REF	4/5 LB	CROSS VALY	B		EA	6.9600	6.96
					READY TO EAT - Please Refer to Return Policy							
1			CS	5326418	LETTUCE, RMM FRESH REF	24 EA	CROSS VALY			CS	34.4500	34.45
1			CS	5327275	BEEF, PTY GRND 80/20 2:1 RND	20/8 OZ	CTLMM SLCT			CS	42.3300	42.33
1			CS	5425814	BEAN, GRN SHPPD FRESH REF BAG	2/5 LB	CROSS VALY			CS	31.0000	31.00
					READY TO EAT - Please Refer to Return Policy							
2			EA	7331614	CELERY, STICK 4" FRESH REF	4/5 LB	CROSS VALY	B		EA	10.8300	21.66
					READY TO EAT - Please Refer to Return Policy							
1			CS	7331960	MUSHROOM, SLCD 1/4" CLND #1	5 LB	CROSS VALY			CS	17.2400	17.24
					READY TO EAT - Please Refer to Return Policy							
1			CS	8350258	MILK, WHL PSTRD RBST FREE D	4/1 GA	GLNWV FAMS			CS	27.8400	27.84
1			EA	9329921	SAUCE, CKTL SEAFO ZESTY FLST	1 GA	MONARCH	B		EA	14.7600	14.76
					READY TO EAT - Please Refer to Return Policy							
1			CS	9437054	FRUIT MIX, 5 WAY FRESH REF	2/8 LB	CROSS VALY			CS	42.2700	42.27
					READY TO EAT - Please Refer to Return Policy							
					FROZEN							
2			CS	1013790	APPETIZER, CHS HONY HOT BITE	27 LB	MOLLYS KIT			CS	84.5600	169.12
1			CS	1083803	DIP, CRM CHS CHIX BACH RANCH	4/4 LB	CHEFS LINE			CS	69.3400	69.34
1			CS	2633394	BREAD, RYE MRBL 17 SLCD 5/8"	8/30 OZ	EURO BAKRY			CS	37.7300	37.73
4			CS	2883130	POTATO, FF SC 3/8" EXTRA CRSPY	6/5 LB	MONARCH			CS	50.1300	200.52
2			CS	3083068	EGG ROLL, VEG 8 Z RAW FZN	10/10/8 OZ	MOLLYS KIT			CS	52.4100	104.82
1			CS	3200145	SALMON, ATLNTC 6 Z PTN PBO 3D	10 LB	HARBOR BNK			CS	100.1400	100.14
2			CS	3330099	HOT DOG, AB 6:1 6" RLR GRIL	10 LB	FATUXENT			CS	31.3500	62.70
1			CS	4072773	SHRIMP, BRDD RAW 54 CT DVN	4/2.5 LB	MRS FRIDAY			CS	63.7100	63.71
2			CS	4960449	POTSTICKER, PORK VEG 1 Z RAW	120/1 OZ	PACIFIC JDE			CS	49.0000	98.00
1			CS	5366760	BREAD, WHT 12.5" 21 SLCD 9/16"	6/28.32 OZ	ROTELLA			CS	26.2500	26.25
1			CS	6252191	POTATO, MSHD SKON RED BOIL IN	6/4 LB	LAMBSUPREN			CS	53.3400	53.34



ACCOUNT INVOICE INVOICE CUSTOMER PURCHASE ORDER  
 NO. NO. DATE NO. NUMBER  
 91221150 1877266 12/31/24 11221140

SALES SALES DATE  
 LOC. REP. ORDERED  
 3055 0832 12/29/24

Route: 2325 / 6

ORDER NUMBER: 7713

Bill

To:

50 VILLAGE COMM DEV DISTR  
 3989 EAGLE LANDING PKWY

Ship

To:

TRN EAGLE LANDING GLF CLB  
 3989 EAGLE LANDING PKWY

Remit

To:

US Foods, Inc.

ORANGE PARK FL  
 32065

ORANGE PARK FL  
 32065  
 904 291 5600  
 DEPT # 00

P.O. BOX 198421

ATLANTA GA  
 30384-8421  
 386 763 1304

Att: CHRIS COLLETTI

Ship From: 5425 S. WILLIAMSON BLVD PORT ORANGE FL Ship D: 12/31/24 Page 01 of 02  
 Terms: NET 21 DAYS Special Instr: DRIVER MUST LEAVE FINAL RECEIPT FOR INV CHANGES  
 Qty Sales Product Description Pack Size Label C Weight Pricing Unit Extended  
 Order Shipped Unit Number Price Price

1 CS 0422956 DRY GRABBER, PAN 8.5X11 100% COTN 1 DZ SUPERIOR CS 45.3900 \$ 45.39

STORAGE LOCATION RECAP(N)

TOTAL DRY PIECES ORDERED: 1 PIECES SHIPPED: 1 ITEMS SHIPPED: 1 45.39

TOTAL NET WGT: 2.25 \*\*\* INVOICE SUMMARY \*\*\*  
 TOTAL GROSS WGT: 2.25 PIECES ORDERED: 1 PIECES SHIPPED: 1 ITEMS SHIPPED: 1

PRODUCT TOTAL \$ 45.39

TAXABLE AMOUNT \$ .00  
 GEN SALES TAX % .00

This amount is an estimate at time of shipping subject to any adjustments made at delivery: \$ 45.39

240-7441=45.39

ACCOUNT INVOICE INVOICE CUSTOMER PURCHASE ORDER  
 NO. NO. DATE NO. NUMBER  
 91221150 1877267 12/31/24 11221140

SALES SALES DATE  
 LOC. REP. ORDERED  
 3055 0832 12/29/84

Route: 2325 / 6

ORDER NUMBER: 8063

Bill To: 50 VILLAGE COMM DEV DISTR  
 3989 EAGLE LANDING PKWY  
 ORANGE PARK FL 32065  
 Att: CHRIS COLLETTI

Ship To: TRN EAGLE LANDING GLF CLB  
 3989 EAGLE LANDING PKWY  
 ORANGE PARK FL 32065  
 904 291 5600  
 DEPT # 00

Remit To: US Foods, Inc.  
 P.O. BOX 198421  
 ATLANTA GA  
 30384-8421  
 386 753 1304

igFrom: 5425 S. WILLIAMSON BLVD FORT ORANGE FL ShipD: 12/31/24 Page 01 of 02  
 tTrms: Special DRIVER MUST LEAVE FINAL RECEIPT FOR INV CHANGES

tTrms: NET 21 DAYS  
 ty Qty Sales Product Description Pack Size Label C Weight Pricing Unit Extended  
 dered Shipped Unit Number Price Price

1	CS	4058707	FROZEN MUFFIN, BANANA NUT TFF 4 Z IW	24/4 OZ	SPUNKMEYER	CS	19.4600	\$	19.46
1	CS	5058680	MUFFIN, BLBRY TFF 4 Z IW FZN	24/4 OZ	SPUNKMEYER	CS	21.4500	\$	21.45

STORAGE LOCATION RECAP(N)

TOTAL FROZEN PIECES ORDERED: 2 PIECES SHIPPED: 2 ITEMS SHIPPED: 2 40.91

TOTAL NET WGT: 12.00 \*\*\* INVOICE SUMMARY \*\*\*  
 TOTAL GROSS WGT: 14.50 PIECES ORDERED: 2 PIECES SHIPPED: 2 ITEMS SHIPPED: 2

PRODUCT TOTAL \$ 40.91

TAXABLE AMOUNT \$ .00  
 GEN SALES TAX % .00

This amount is an estimate at time of shipping prior to any adjustments made at delivery: \$ 40.91

000  
 240-1340 = 4091

ACCOUNT INVOICE INVOICE CUSTOMER PURCHASE ORDER  
 NO. NO. DATE NO. NUMBER  
 91221150 1877268 12/31/24 11221140

SALES SALES DATE  
 LOC. REP. ORDERED  
 3055 0832 12/29/24

Route: 2325 / 6

ORDER NUMBER: 8192

Bill

To:

50 VILLAGE COMM DEV DISTR  
 3989 EAGLE LANDING PKWY  
  
 ORANGE PARK FL  
 32065  
  
 Att: CHRIS COLLETTI

Ship

To:

TRN EAGLE LANDING GLF CLB  
 3989 EAGLE LANDING PKWY  
  
 ORANGE PARK FL  
 32065  
 904 291 5600  
 DEPT # 00

Remit

To:

US Foods, Inc.  
 P.O. BOX 198421  
  
 ATLANTA GA  
 30384-8421  
 386 763 1304

Big From: 5425 S. WILLIAMSON BLVD PORT ORANGE FL Ship to: 12/31/24 Page 01 of 02  
 Terms: Special Instr: DRIVER MUST LEAVE FINAL RECEIPT FOR INV CHANGES

Order	Qty	Sales	Product	Description	Pack	Size	Label	D	Weight	Pricing	Unit	Price	Extended
Number	Shipped	Unit	Number							Unit			Price

1	CS	7905482	DRY SUGAR SUB, YLW SPLDA 1 GR SS 2000 EA	SPLENDA						CS	32.3500	4	32.35
---	----	---------	--	---------	--	--	--	--	--	----	---------	---	-------

STORAGE LOCATION RECAP(N)

TOTAL DRY	PIECES ORDERED:	1	PIECES SHIPPED:	1	ITEMS SHIPPED:	1							32.35
-----------	-----------------	---	-----------------	---	----------------	---	--	--	--	--	--	--	-------

TOTAL NET WGT:	4.40	PIECES ORDERED:	1	PIECES SHIPPED:	1	ITEMS SHIPPED:	1						
TOTAL GROSS WGT:	5.80												

PRODUCT TOTAL \$ 32.35

TAXABLE AMOUNT \$ .00  
 GEN SALES TAX % .00

This amount is an estimate at time of shipping prior to any adjustments made at delivery: \$ 32.35

000  
 240-1340 = 32.35

ACCOUNT NO. 91221150  
 INVOICE NO. 1877269  
 INVOICE DATE 12/31/24  
 CUSTOMER NO. 11221140  
 PURCHASE ORDER NUMBER

SALES LOC. 3055  
 SALES REP. 0832  
 DATE ORDERED 12/29/24

ORDER NUMBER: 8280

Route: 2325 / 6

Bill To:  
 50 VILLAGE COMM DEV DISTR  
 3989 EAGLE LANDING PKWY  
 ORANGE PARK FL  
 32065  
 Attn: CHRIS COLLETTI

Ship To:  
 TRN EAGLE LANDING GLF CLB  
 3989 EAGLE LANDING PKWY  
 ORANGE PARK FL  
 32065  
 904 291 5600  
 DEPT # 00

Remit To:  
 US Foods, Inc.  
 P.O. BOX 198421  
 ATLANTA GA  
 30384-8421  
 386 763 1304

Ship From: 5425 S. WILLIAMSON BLVD PORT ORANGE FL  
 Terms: NET 21 DAYS  
 Qty Sales Product Description

Ship Date: 12/31/24  
 Social Instr: DRIVER MUST LEAVE FINAL RECEIPT FOR INV CHANGES  
 Page 01 of 02

Order	Shipped	Unit	Number	Description	Pack Size	Label	Weight	Pricing Unit	Unit Price	Extended Price
-------	---------	------	--------	-------------	-----------	-------	--------	--------------	------------	----------------

1	CS	1306653	DRY MUSTARD, YLM SQZ RTL SHLF	12/12 OZ	FRENCH'S			CS	14.3300	\$ 14.33
---	----	---------	-------------------------------	----------	----------	--	--	----	---------	----------

STORAGE LOCATION RECAP(N)

TOTAL DRY                      PIECES ORDERED: 1      PIECES SHIPPED: 1      ITEMS SHIPPED: 1      14.33

TOTAL NET WGT: 9.00      \*\*\* INVOICE SUMMARY \*\*\*  
 TOTAL GROSS WGT: 10.70      PIECES ORDERED: 1      PIECES SHIPPED: 1      ITEMS SHIPPED: 1

PRODUCT TOTAL \$ 14.33

TAXABLE AMOUNT \$ 00  
 GEN SALES TAX % .00

This amount is an estimate at time of shipping prior to any adjustments made at delivery: \$ 14.33

000  
~~240~~ 1340 = 14.33

ACCOUNT NO. 91221150    INVOICE NO. 1973387    INVOICE DATE 01/03/25    CUSTOMER NO. 11221140    PURCHASE ORDER NUMBER    SALES LOC. 3055    SALES REP. 0532    DATE ORDERED 12/29/24

Route 5338 / 7

ORDER NUMBER: 7778

Bill To: SD VILLAGE COMM DEV DISTR  
3989 EAGLE LANDING PKWY  
ORANGE PARK FL 32065  
Att: CHRIS COLLETTI

Ship To: TRN EAGLE LANDING CLF C/D  
3989 EAGLE LANDING PKWY  
ORANGE PARK FL 32065  
904 291 5600  
DEPT # 00

Remit To: US Foods, Inc  
P O BOX 192421  
ATLANTA GA 30384-8421  
304 763 1304

Ship From: 5425 S WILLIAMSON BLVD PORT ORANGE FL    Ship Date: 01/03/25    Page 03 of 04  
 Frt Terms:    Special Instr: DRIVER MUST LEAVE FINAL RECEIPT FOR INV CHAP  
 Pmt Terms: NET 21 DAYS  
 Qty Ordered    Qty Shipped    Sales Unit    Product Number    Description    Pack Size    Label    C/D    Weight    Pricing Unit    Unit Price    Extended Price

\*\*\* INVOICE SUMMARY \*\*\*  
 TOTAL NET WGT: 1065.59    PIECES ORDERED: 64    PIECES SHIPPED: 62    ITEMS SHIPPED: 43  
 TOTAL GROSS WGT: 1160.82

PRODUCT TOTAL \$ 2722.55

\* Federal Occupation Safety and Health Standards, Section 1910.1200 on Hazard  
 \* Communication requires manufacturers and distributors to provide Material  
 \* Safety Data Sheets on non-food products defined to be hazardous Products  
 \* such as cleaning products and pesticides are included in the scope of the  
 \* Standard. In compliance with the law, MSDS are available to US Foods, Inc.  
 \* customers and can be obtained by contacting the Procurement Manager in our  
 \* district office or by advising your sales representative.  
 \* You may contact HAZMAT HOTLINE at phone # (800) 424 - 8802.

TAXABLE AMOUNT \$ .00  
 CFM SALES TAX % .00

This amount is an estimate at time of shipping prior to any adjustments made at delivery: \$ 2722.55

\* You agree with respect to any dispute arising out of your purchase from  
 \* US Foods: (i) you are giving up your right to serve in any representati  
 \* capacity; or to participate as a member of a class, in any lawsuit, (ii) yo  
 \* also agree, at US Foods sole option, to submit to binding, individual  
 \* arbitration of all claims; (iii) such arbitration shall be governed by the  
 \* Federal Arbitration Act, 9 U.S.C. s.1 and conducted in accordance with the  
 \* Commercial Rules of the American Arbitration Association, and (iv) each pa  
 \* shall pay half the costs of arbitration, and separately pay its own attorney's  
 \* fees and costs. For more information about the fuel surcharge, go to  
 \* https://www.usfoods.com/terms/fuelsurcharge/StandardGridEIAAreaLowerAtlant  
 \* Sm  
 \* If you have an agreement with US Foods that expressly addresses the  
 \* calculation of the fuel surcharge, please refer to that agreement.

000  
~~240-1340~~ = 2550.76  
 500-7450 = 171.79  
 Total = 2722.55

ACCOUNT INVOICE INVOICE CUSTOMER PURCHASE ORDER  
 NO. NO. DATE NO. NUMBER  
 91221150 1973827 01/03/25 11221140

SALES SALES DATE  
 LOC. REP. ORDERED  
 3055 0832 12/29/24

Route 5338 / 7

ORDER NUMBER: 7775

Bill To: SD VILLAGE COMM DEV DISTR  
 3989 EAGLE LANDING PKWY  
 ORANGE PARK FL 32065  
 Attn: CHRIS COLLETTI

Ship To: TRN EAGLE LANDING CLF CLS  
 3989 EAGLE LANDING PKWY  
 ORANGE PARK FL 32065  
 904 291 5600  
 DEPT # 00

Remit To: US Foods, Inc.  
 P O BOX 198421  
 ATLANTA GA 30384-8421  
 888 763 1304

Ship From: 5425 S. WILLIAMSON BLVD PORT ORANGE FL Ship Date: 01/03/25 Page 01 of 04  
 Frt Trms: DRIVER MUST LEAVE FINAL RECEIPT FOR INV CHAN  
 Pmt Trms: NET 21 DAYS

Qty Ordered	Qty Shipped	Sales Unit	Product Number	Description	Pack Size	Label	C Weight	Pricing Unit	Unit Price	Extended Price
-------------	-------------	------------	----------------	-------------	-----------	-------	----------	--------------	------------	----------------

HAZARDOUS MATERIALS

1	1	CS	2328813	DRY OIL, PAN COTG SOYBN OIL BASED 6/14 07 0451-AEROSOL		NONHARCH		CS	18.9700	4	18.97
---	---	----	---------	--	--	----------	--	----	---------	---	-------

TOTAL HAZARDOUS WEIGHT: 5.25 TOTAL HAZARDOUS PIECES: 1 TOTAL HAZARDOUS CURE: .24

1	1	CS	0719427	DRY LTD. CUP 12-20 Z PLST WHT SLOT 10/100 EA		MONOGRAM		CS	27.3900	1	27.39
1	1	EA	1023134	SPICE, CUMIN GRND SHLF STABL 14 OZ		MCCORMICK		EA	12.4300		12.43
3	3	CS	1328699	SHORTENING, FRIG SOYBN LTR CLR 35 LB		HARVEST VL		CS	32.0100		96.03
1	1	EA	1401124	SPICE, CHILI DARK PWDR SHLF 20 OZ		MCCORMICK		EA	12.2300		12.23
1	1	CS	2333239	CHIP, ASST SS BAG SHLF STABL 2/30 EA		FRITO LAT		CS	41.0300		41.03
1	1	CS	3112695	DRINK, SODA COLA DIET COKE CAN 24/12 OZ		COKE		CS	18.2900		18.29
2	2	CS	3554565	DRINK, SODA COLA COKE CLSC CAN 24/12 OZ		COKE		CS	18.2900		36.58
1	1	CS	4034385	LINER, PAN FOOD 16.37X24.37 1000 EA		DIXIE		CS	47.2000		47.20
1	1	EA	4146478	SEASONING, STK MNTL RUB SHLF 7 LB		MCCORMICK		EA	49.0300		49.03
1	1	CS	5051368	TORTILLA, CHIP RAW 4 CUT TRI 30/LB		LA BNDRITA		CS	31.1700		31.17
2	2	CS	5851351	GLOVE, VINYL XL PF CLR ANBOX 10/100 EA		VALU CARES		CS	21.6700		43.26
1	1	CS	7802523	NAPKIN, DMNK WHT 17X17 1 PLY 20/250 EA		VALU PLUS		CS	53.9400		53.94
1	1	CS	0204505	DRINK, RSP BLU COOL PLST BTL 24/20 OZ		BATOPAGE		CS	23.9800		23.98

REFRIGERATED

1	1	CS	0454210	PEPPER, BELL GREEN CHOICE FRESH 1 LB		PACKER		CS	17.6900		17.69
1	1	CS	1492816	CHEESE, PARM SHVD PAD REF 2/5 LB		ROBELT		CS	44.6500		44.65
1	1	EA	2348935	CARROT, STICK 3 3/4" FRESH 5 LB READY TO EAT - Please Refer to Return Policy		CROSS VALY		EA	8.9400		8.94
3	3	CS	2721123	CHICKEN, WING 1829T UNB RAW 4/10 LB		PATUXENT		CS	94.1200		282.36
3	3	CS	2725711	CHICKEN, DRST SNGL 6 Z BNLS 4/5 LB		PATUXENT		CS	48.0300		144.09
1	1	CS	2971551	HAM, SLCD 67 Z W/A SMKD CKD 6/2 LB READY TO EAT - Please Refer to Return Policy		HILLSHIRE		CS	48.6900		48.69
1	1	CS	3331998	BROCCOLI, FLORT MINI ICELS REF 4/3 LB READY TO EAT - Please Refer to Return Policy		CROSS VALY		CS	37.7300		37.73
1	1	CS	3340510	CHEESE, AMER SLCD 120 BT TFF 4/5 LB		GLNVW FRMS		CS	53.7700		53.77
1	1	CS	4264530	PEPPER, BELL RED CHO FRESH REFS LB		PACKER		CS	16.0100		16.01
1	1	EA	4332011	CABBAGE, RED SHRD 1/8" DILO PK5 LB		CROSS VALY		EA	6.4700		6.47



ACCOUNT INVOICE INVOICE CUSTOMER PURCHASE ORDER  
 NO. NO. DATE NO. NUMBER  
 91221150 1973227 01/03/25 11221140

SALES SALES DATE  
 LOC. REP. ORDERED  
 3055 0832 12/27/24

Route: 5338 / 7

ORDER NUMBER 7778

Bill To: 50 VILLAGE COMM DEV DISTR  
 3989 EAGLE LANDING PKWY  
 ORANGE PARK FL  
 32065  
 Att: CHRIS COLLETTI

Ship To: TRN EAGLE LANDING OLY CLR  
 3989 EAGLE LANDING PKWY  
 ORANGE PARK FL  
 32065  
 904 291 5600  
 DEPT # 00

Remit To: US Foods, Inc  
 P.O. BOX 198421  
 ATLANTA GA  
 30384-8421  
 386 753 1304

Ship From: 5425 S. WILLIAMSON BLVD PORT ORANGE FL Ship Date: 01/03/25 Page 07 of 04  
 Fmt Terms: NET 31 DAYS Special Inset DRIVER MUST LEAVE FINAL RECEIPT FOR INV CHAT  
 Qty Ordered Qty Shipped Sales Unit Product Description Pack Size Label C Weight Pricing Unit Price Extended Price

Qty Ordered	Qty Shipped	Sales Unit	Product Description	Pack Size	Label	C	Weight	Pricing Unit	Unit Price	Extended Price
1	1	CS	5326418	READY TO EAT - Please Refer to Return Policy						
5	5	CS	5327275	LETTUCE, ROM FRESH REF	24 EA			CS	34.4500	34.45
1	1	CS	4213391	BEEF, PTY GRND 80/20 2:1 RND	20/8 OZ			CS	42.3300	211.65
1	1	EA	7331614	DRESSING, CRK CRNY SPCL PLST	9/1 GA			CS	54.3400	54.34
1	1	EA	7331614	CELERY; STICK 4" FRESH REF	4/5 LB			EA	10.8300	10.83
1	1	CS	9124520	READY TO EAT - Please Refer to Return Policy						
1	1	CS	9124520	DRESSING, RANCH HMSTY PLST JAR4/1 GA				CS	46.0800	46.08
1	1	CS	0488239	READY TO EAT - Please Refer to Return Policy						
1	0	CS	1054265	FROZEN						
1	1	CS	1475608	ROLL, HOBI WHT 8" SLCD BKD FZM8/6/3.7 OZ				CS	31.0200	31.02
1	1	CS	2122328	BUN, HOT DDB WHT 6" SLCD CKD 8/12/1 7 OZ				CS	26.2900	26.29
1	1	CS	2122328	BREAD, FLAT 5X13" OVAL BKD FZM36/3.61 OZ				CS	11.4200	104.04
1	1	CS	0511301	BEEF, STK T8D TP CC 1184B 60Z424/6 OZA			9.11	CS		
5	5	CS	2883130	CS: 0001 9.11 LBS						
1	1	CS	3200145	GROUPEL, BRD TENDR PARFR FISH4/7 LB				CS	117.7100	117.71
1	1	CS	4326980	POTATO, FF SC 3/8" EXTRA CRSPY6/5 LB				CS	50.1300	250.65
1	1	CS	4050495	SALMON, ATLNTC 6 Z PTN P80 3D 10 LB				CS	100.1600	100.16
1	1	CS	5915319	MAHI MAHI, 6 Z PC BLGL RAW FZM10 LB				CS	72.9500	72.95
1	0	CS	6253758	BACON, PORK 10-22C SLD LAID 2015 LB				CS	65.4300	65.43
3	3	CS	6911663	APPETIZER, CHS MOZZ BRDD	6/2 LB			CS	31.8100	95.43
1	1	CS	7233562	ROLL, KSR WHT 4.5" SLCD BKD 6/8/3.5 OZ				CS	39.0800	39.08
1	1	CS	7837713	PANGASIUUS, STPED 5-7 Z FIL P8015 LB				CS	38.9100	38.91
2	2	CS	9205147	MACARONI & CHEESE, CHEDR PRCKD36/7 OZ				CS	39.9600	79.92
1	1	CS	9870536	CHICKEN, TNDLN BRD FRTR BEER2/5 LB				CS	25.0000	25.00
1	1	CS	9870536	BEEF, PTY GRND 75/25 3:1 HMSTY30/5 33 OZ				CS	31.0100	31.01
1	1	CS	9870536	CHICKEN, BRST 3.5 Z BRDD HMSTY2/5 LB				CS		

STORAGE LOCATION RECAP(H)

TOTAL DRY	PIECES ORDERED:	18	PIECES SHIPPED:	18	ITEMS SHIPPED:	14	511.54
TOTAL REFRIGERATED	PIECES ORDERED:	23	PIECES SHIPPED:	23	ITEMS SHIPPED:	15	1078.41
TOTAL FROZEN	PIECES ORDERED:	23	PIECES SHIPPED:	21	ITEMS SHIPPED:	14	1132.60



ACCOUNT NO. 91221150 INVOICE NO. 1973828 INVOICE DATE 01/03/25 CUSTOMER NO. 11221140 PURCHASE ORDER NUMBER SALES LOC 3055 SALES REP 0832 DATE ORDERED 01/03/25

Route: 5338 / 7

ORDER NUMBER 14775

Bill To: 50 VILLAGE COMM DEV DISTRICT  
3989 EAGLE LANDING PKWY  
ORANGE PARK FL 32065  
Att: CHRIS COLLETTI

Ship To: TRN EAGLE LANDING CLF CLD  
3989 EAGLE LANDING PKWY  
ORANGE PARK FL 32065  
904 291 5600  
DEPT # 00

Remit To: US Foods, Inc  
P.O. BOX 193421  
ATLANTA GA 30384-8421  
336 763 1304

Ship From: 5425 S. WILLIAMSON BLVD PORT ORANGE FL 32129  
Special Instr: DRIVER MUST LEAVE FINAL RECEIPT FOR INV CHAI  
Page 01 of 02

Terms: NET 21 DAYS  
Qty Ordered Qty Shipped Sales Unit Product Description Pack Size Label C Weight Pricing Unit Price Extended Price

Qty Ordered	Qty Shipped	Sales Unit	Product	Description	Pack Size	Label	C	Weight	Pricing Unit	Unit Price	Extended Price	
2	2	CS	5327275	REFRIGERATED BEEF, PTY BRND 80/20 2:1 RND 20/S OZ		CTLMN SLCT			CS	42.3300	84.66	
2	2	CS	7437713	FROZEN CHICKEN, TNDLN BRD FRITR BEER2/5 LB		PATXENT			CS	39.9600	79.92	
STORAGE LOCATION RECAP(N)												
TOTAL REFRIGERATED			PIECES ORDERED:		2	PIECES SHIPPED:		2	ITEMS SHIPPED:		1	84.66
TOTAL FROZEN			PIECES ORDERED:		2	PIECES SHIPPED:		2	ITEMS SHIPPED:		1	79.92
*** INVOICE SUMMARY ***												
TOTAL NET WGT: 40.00			PIECES ORDERED:		4	PIECES SHIPPED:		4	ITEMS SHIPPED:		2	
TOTAL GROSS WGT: 43.20												

\*\*\*\*\*  
 \* Federal Occupation Safety and Health Standards, Section 1910.1200 on Hazard  
 \* Communication requires manufacturers and distributors to provide Material  
 \* Safety Data Sheets on non-food products defined to be hazardous. Products  
 \* such as cleaning products and pesticides are included in the scope of the  
 \* Standard. In compliance with the law, MSDS are available to US Foods, Inc.  
 \* customers and can be obtained by contacting the Procurement Manager in our  
 \* district office or by advising your sales representative.  
 \* You may contact HAZMAT HOTLINE at phone # (800) 424 - 8802  
 \*\*\*\*\*  
 TAXABLE AMOUNT \$ 00  
 GEN SALES TAX 2 .00  
 PRODUCT TOTAL \$ 164.58  
 This amount is an estimate at time of shipping price and subject to change at delivery \$ 164.58

*[Handwritten signature]*

000  
240-1340 = 164.58

# Invoice



SOUTH VILLAGE COMMUNITY  
DEVELOPMENT DBA EAGLE LANDING  
GOLF CLUB  
3989 EAGLE LANDING PARKWAY  
ORANGE PARK FL 35065

**Ship-to address**

SHIP TO  
3989 EAGLE LANDING PARKWAY  
ORANGE PARK FL 35065

Invoice No. : 475865  
Customer No. : ELG002  
Doc. date : 8/1/2024  
Due date : 8/31/2024  
Page : 1 of 1  
Customer ref.

Item no.	Item name	Qty.	UOM	Price	Total
SOILSAMPLES2	LOGAN LABS SOIL SAMPLE	1.00	EA	30.00	30.00

400-7760  
1/1/2025

*[Handwritten signature]*  
*[Handwritten signature]*  
1/7/25

1% MONTHLY FINANCE CHARGES ARE ADDED AFTER THE DUE DATE PLUS ANY COLLECTION COSTS INCLUDING ANY ATTORNEY FEES AND ATTORNEY EXPENSES. ALL RETURNED ITEMS ARE SUBJECT TO A 25% RESTOCKING FEE. SHORTAGE MUST BE NOTED ON DELIVERY SLIP.  
THANK YOU FOR YOUR ORDER!

SubTotal		Tax	Total
30.00		0.00	30.00
		Applied	0.00
		<b>Balance</b>	<b>\$30.00</b>



**ACUSHNET COMPANY**  
 P.O. BOX 965 FAIRHAVEN, MA 02719-0965  
 Tel: 800-225-8500 Fax: 508-979-3913



**INVOICE**  
 Currency: USD

Tax No: 04-2591836

Invoice No 819304737		Invoice Date 11/29/24	Shipment Date 11/29/24	Order Date 10/31/24
Order No 3025068457	Whs 07E	Delivery No 59662309	Customer P.O. HEADWEAR FILL	Account No US00027669 \ US00040574

<b>Sold To</b> SOUTH VILLAGE COMMUNITY DEVELOP DISTRICT DBA EAGLE LANDING GOLF CLUB 3989 EAGLE LANDING PKWY ORANGE PARK FL 32065-2641	<b>Ship To</b> EAGLE LANDING GOLF CLUB ATTN PRO SHOP 3989 EAGLE LANDING PKWY ORANGE PARK FL 32065-2641
---	--

<b>Remit To</b> Acushnet Company P.O. Box 830334 Philadelphia, PA 19182-0334	<b>Payment Terms</b> Net 60 Days <b>Payment Discount</b> NA <b>Delivery Method</b> FedEx Ground	<b>Due Date</b> 01/28/25  <b>Frnt Acct No</b>
---	--	--

Item No	Shipped	U/M	Unit	Disc	Disc	Disc	Cstm	Net	Extended
TH22ATPC-0C1 Tour Performance Char/Wht CST Order Notes: Wearer's Right: Embroidery, 498030, Color Coordinate	12	EA	\$17.50	2%			\$3.00	\$20.15	\$241.80
TH22ATPC-10 Tour Performance Whi/Blk CST Order Notes: Wearer's Right: Embroidery, 498030, Color Coordinate	12	EA	\$17.50	2%			\$3.00	\$20.15	\$241.80
<b>Total Shipped Qty.</b>	<b>24</b>								

**Net Order Total** \$483.60  
**Total Invoice** \$483.60

*[Handwritten signature]*  
 12/10/24

*[Handwritten signature]*

2275-000  
~~1320-100~~

Effective December 1, 2024 Acushnet Golf will no longer mail invoice and statement documents.  
 Please contact us at 800-225-8500 to set-up electronic delivery today.  
 You can access your account online at Acushnetgolf.com.

Invoices not paid within thirty (30) days of due date shall incur a service charge at the rate of the lesser of one and one-half percent (1.5%) per month or the highest rate permitted by law on any outstanding overdue balance from original due date.  
 SEE REVERSE SIDE FOR CONDITIONS OF SALE.



by Darling Ingredients

DARLING INGREDIENTS INC.  
5601 N MacArthur Blvd  
Irving, TX 75038  
904-964-8083

Invoice		
Invoice Number	Date	Page
13823095	12/21/2024	1 / 1
Bill To Cust No.	Terms	Billing Period
208613	Due Upon Receipt	12/15-12/21

**BILL TO** EAGLE LANDING SWIM AND TENNIS  
3975 EAGLE LANDING PKWY  
ORANGE PARK FL 32065



Cust. No.	Store No.	Customer	PO No.	Description	Svc Date	Ticket No.	Quantity	UOM	Unit Price	Extended Amount
208613		EAGLE LANDING SWIM AND TENNIS 3975 EAGLE LANDING PKWY ORANGE PARK, FL 32065								
		Trap#1 ADMIN FEE TRAP			12/16/24	28328755	1.00	EA	5.00000	5.00
		Trap#1 SERVICE FEE TRAP EXT			12/16/24	28328755	1.00	EA	500.00000	500.00
		Trap#1 TRAP ENVIRO COMPLIANCE FEE			12/16/24	28328755	1.00	EA	5.00000	5.00

Invoice Total: 510.00  
 Applied Payments: 0.00  
 Net Amount Due: USD 510.00

4W-7600  
 [Handwritten signature]  
 1/14/25

PLEASE DETACH AND SEND THIS COUPON WITH YOUR PAYMENT



PAY YOUR INVOICE ONLINE AT:  
<https://paymydarlingbill.com>

REMITTANCE ADVICE  
PLEASE RETURN  
WITH YOUR PAYMENT

ACCOUNT NUMBER 208613	INVOICE DATE 12/21/2024	INVOICE NUMBER 13823095	AMOUNT DUE USD 510.00
--------------------------	----------------------------	----------------------------	--------------------------

REMIT TO: DARLING INGREDIENTS INC.  
PO BOX 554885  
DETROIT MI 48255-4885

BILL TO: EAGLE LANDING SWIM AND TENNIS  
3975 EAGLE LANDING PKWY  
ORANGE PARK FL 32065

# ECOLAB®

Pest Elimination  
26252 Network Place  
Chicago, IL 60673-1262  
1-800-325-1871

INVOICE NUMBER  
**6404646**

ACCOUNT NUMBER	LOC.	DATE OF ORDER	DATE SHIPPED	SALESPERSON NO.	P.O. NUMBER
EAGL0279	0001	12/31/24	12/31/24	359001	

(SAME AS BILLED TO UNLESS INDICATED BELOW)

B I L L T O	TO
EAGLE LANDING GOLF CLUB 3989 EAGLE LANDING P  ORANGE PARK FL 32065 2641	EAGLE LANDING GOLF C 3989 EAGLE LANDING P  ORANGE PARK FL 32065 2641 CONTACT: TAX CREDITS

TERMS: AMT DUE 10 DAYS FROM DATE SHIPPED

SHIPPED AMOUNT DUE 22.92CR

BUYER'S CERTIFICATION #  
RESTRICTED USE PRODUCTS

RETURN THIS PORTION WITH PAYMENT TO RECEIVE PROPER CREDIT

AMOUNT ENCLOSED \$

QUANTITY ORDERED	QUANTITY BACK ORDER	QUANTITY SHIPPED	DESCRIPTION	PRODUCT CODE	UNIT PRICE	TOTAL PRICE

7850-500

PLEASE PAY FROM INVOICE. MONTHLY STATEMENTS WILL NOT BE SENT UNLESS REQUESTED

NO ARTICLE LISTED ABOVE IS SOLD FOR USE AS FOOD, DRUG OR COSMETIC UNLESS SPECIFICALLY DESIGNATED. WE CERTIFY THAT THE GOODS COVERED BY THIS INVOICE WERE PRODUCED IN ACCORDANCE WITH THE FAIR LABOR STANDARDS ACT OF 1938 AS AMENDED.

INVOICE NUMBER  
**6404646**

# ECOLAB®

Pest Elimination  
26252 Network Place  
Chicago, IL 60673-1262  
1-800-325-1871

FI 0301

ORIGINAL INVOICE

SUB TOTAL	.00
STATE TAX	18.34CR
CITY TAX	.00
COUNTY TAX	.00
SHIPPING & HANDLING	4.58CR
	.00
INVOICE TOTAL →	22.92CR

Pay your invoice ONLINE through Ecolab Easy Pay - visit [easypay.ecolab.com](http://easypay.ecolab.com) or scan QR Code for access.

*Credit Received*

*S. M. / 1/15*



INVOICE  
CUSTOMER SERVICE  
REPORT

INVOICE  
NUMBER 7133765

PAGE 1

1-800-325-1671

PLEASE REMIT PAYMENT TO:  
PEST ELIMINATION  
26252 NETWORK PLACE  
CHICAGO, IL 60673-1262

BILLING ADDRESS

EAGLE LANDING GOLF CLUB  
3989 EAGLE LANDING PKWY  
ORANGE PARK FL 32065-2641 US  
BILL PH: 904-637-0640

ACCOUNT INFORMATION:

ACCOUNT NO. EAGL0279-0001-01  
SVSP # 355203  
SERVICE SPECLST HARTFIELD, KATELYNN  
LICENSE NUMBER JE342769  
CORP REF # 98909

SERVICE ADDRESS

EAGLE LANDING GOLF CLUB  
3989 EAGLE LANDING PKWY  
ORANGE PARK FL 32065-2641 US  
SERV PH: 904-637-0640

SERVICE

Cockroach/Rodent Program 258.23  
Energy Surcharge  
Outside-In Lge Fly 12 Mm Bill 44.65

QTY INVOICE AMT

SERVICE PERIOD: MONTHLY (A)  
SERVICE DATE: 1/02/2025

SPECIAL INSTRUCTIONS:

12-MONTH BILLING, DO NOT SERVICE OUTSIDE-IN LG FLY  
PGM THIS MONTH

TERMS NET 30 DAYS

STATE TAX: 6.000  
CITY TAX:  
CNTY TAX: 1.500

SUB TOTAL: 302.88

TOTAL: 302.88

AMOUNT DUE: 302.88

ADDITIONAL COMMENTS

CUSTOMER'S SIGNATURE

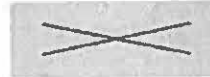

No Customer Onsite

TARGET PEST	PRODUCT USED	PRODUCT CODE	LOT NUMBER	ADD'L INFO	QUANTITY	METHOD	SITES
Rats	FIRSTSTRIKE SOFT BAIT 10 GM	502			8.00	EA 000006	C14
Cockroaches	ADVION COCKROACH GEL BAIT	608			10.00	GM 000001	C01
Cockroaches	ALPINE WSG INSECTICIDE	691			1.00	GA 000001	C01 C08
Cockroaches	DEMAND CS INSECTICIDE	340			1.50	GA 000001	C21 C09 C57
Flies - Large	DEMAND CS INSECTICIDE	340			1.00	GA 000002	C53 C06 C07 C80 C02 C57 C53 C07 C80 C54 C55
Flies - Large E	STEALTH MAX BULB SHATTERPROOF				1.00	EA 000013	C01
Flies - Large E	STEALTH MAXIMA GLUEBOARD				2.00	EA 000013	C01
Flies - Small	NYGUARD IGR CONCENTRATE	583			1.00	GA 000001	C01 C08

PRODUCT

CODE	PRODUCT USED DESCRIPTION/EPA NUMBER
502	FirstStrike Soft Bait (0.0025%) 7173-258
608	Advion Cockroach Bait Gel (0.6%) 100-1484
691	Alpine WSG Insecticide (0.3%) 499-561
340	Demand CS (0.06%) 100-1066
340	Demand CS (0.06%) 100-1066
583	NyGuard IGR Concentrate (0.02%) (8 ml per gallon) 1021-1603

METHODS

000001 Crack & Crevice  
000002 Spot  
000006 Bait Station  
000013 Placement

SITES

C01 Kitchen Area-Interior  
C02 Office Area-Interior  
C06 Hallways-Interior  
C07 Lobby Door-Introduction Point  
C08 Lounge/Bar-Interior  
C09 Dining-Interior  
C14 Exterior Area  
C21 Bathroom/Locker Room-Interior  
C53 Front Door-Introduction Point

*Handwritten notes:*  
1/3/24  
7850  
500-



Account Number: A00001702  
 Account Balance: \$1,475.00  
 Account Currency: USD

Eagle Landing Golf Club  
 Jim Hahn  
 3989 Eagle Landing Pkwy  
 Orange Park, Florida 32065-2641  
 United States

**Invoice Summary**

Invoice Number: INV00097588  
 Invoice Date: 11/05/2024  
 PO Number:  
 Invoice Total: \$737.50  
 Due Date: 12/05/2024  
 Invoice Balance: \$737.50

**CHARGES**

Product	Charge Description	Service Period	Subtotal	Tax	TOTAL
Golf365 Premier Tee Sheet (Cloud based)	Golf365 Premier Tee Sheet (Cloud based) with Booking Engine and EZTP Users	11/01/24 - 11/30/24	\$737.50	\$0.00	\$737.50

Customer Payment Portal: <https://paymentsportal.golfnow.com>

OR

**Mall Remit To:**  
 GolfNow  
 PO Box 742569  
 Atlanta, GA 30374-2569

**Wire/ACH Payment To:**  
 Bank of America  
 Wire ABA Routing No.: 026009593  
 ACH Routing No.: 111000012  
 Bank Acct No: 4427779172  
 International SWIFT Code: BOFAUS3N  
 Account Name: Eagle Landing Golf Club  
 Account No: A00001702

Discounts	\$0.00
Invoice Total	\$737.50
Payments / Credits	
Invoice Balance	\$737.50
Account Balance	\$1,475.00

**IMPORTANT:** Please remit payment to GolfNow and reference Inv Number: INV00097588  
 If you have questions, please notify your sales representative and/or email [AR-GolfNow@nbcuni.com](mailto:AR-GolfNow@nbcuni.com).

**USAGE SUMMARY** (if applicable)

Location	Description	Period	Quantity	Rate	Total
----------	-------------	--------	----------	------	-------

1111-7310  
 [Handwritten signature]  
 11/14/25





Handwritten: 100/1325  
000

Remit To: GT Golf Holdings, Inc.  
GT Golf Supply Co  
981 Park Center Drive  
Vista CA 92081  
United States

Invoice #INV512210

Sales Order #SO389580

PO #tee fill in

Date: 11/27/2024  
Due Date: 1/26/2025  
Terms: 2% 30 - Net 60  
Tracking #: 1ZV955920396909391  
Sales Rep: 70 Chris Orphey  
Customer ID: 8422

Total  
USD 291.76



Pay with the QR code, or click this [secure link](#). You can also copy the link to clipboard.

Order Notes:

Bill To:

\*\*\*ATTN: GOLF SHOP\*\*\*  
Eagle Landing Golf Club  
3989 Eagle Landing Pkwy  
Orange Park FL 32065  
United States

Ship To:

\*\*\*ATTN: GOLF SHOP\*\*\*  
Eagle Landing Golf Club  
3989 Eagle Landing Pkwy  
Orange Park FL 32065  
United States

Item	Description	Qty Shp	Qty B/O	Price	Total Amt
11332	Tees-2 3/4" White 50 Pk Pride Printed Poly Bag	72	0	1.55	111.60
11336	Tees-3 1/4" White 50 Pk Pride Printed Poly Bag	72	0	2.15	154.80
Subtotal					266.40
Shipping Cost (SHGround 5)					5.00
Tax Total					20.36
<b>Total</b>					<b>USD 291.76</b>
<b>Payments/Credits</b>					<b>USD \$0.00</b>
<b>Balance Due</b>					<b>USD \$291.76</b>

Handwritten signature and date: 12/20/24

"Questions about this Invoice? Contact Accounting Dept."  
Email: ar@ggolf.com  
Phone: 800-757-7453 (Option 2)  
Order and Pay Bills 24/7 on [www.ggolf.com](http://www.ggolf.com)

Payment Link  
To access secure payment options at any time, click this [secure link](#). You can also copy the link to clipboard.



**verizon**

JAMES HAHN  
1044 MEADOW VIEW LN  
ST AUGUSTINE, FL 32092-1055

Bill date November 15, 2024  
Account number 886435336-00001  
Invoice number 4729342076

**Total Amount Due**

Deducted from bank account on 12/09/24  
DO NOT MAIL PAYMENT

**\$150.56**

Please see back for instructions on writing to us.

PO BOX 16810  
NEWARK, NJ 07101-6810



47293420760108864353360000100000015056000000150567



Harrell's LLC  
 PO Box 807  
 Lakeland, FL 33802  
 1-800-780-2774 option 3  
 Fax: 1-863-904-1545  
 E-mail: creditar@harrells.com

# INVOICE

INVOICE NUMBER	INVOICE DATE
INV01982030	12/31/2024
CUSTOMER NUMBER	TOTAL DUE
EAGLAN2	\$560.00

400-7770  
 1/1/25  
 JF

**BILL TO:**

EAGLE LANDING GOLF CLUB  
 3989 EAGLE LANDING PKWY  
 ORANGE PARK, FL 37065  
 UNITED STATES OF AMERICA

**PAYMENT ADDRESS:**

Harrell's, LLC  
 P O Box 935358  
 Atlanta GA 31193-5358

DETACH UPPER PORTION AND RETURN WITH PAYMENT

PO NUMBER	TERMS	SALESPERSON	CUSTOMER NUMBER	INVOICE NUMBER	SHIP DATE
OLKH1011148	Net 30	103	EAGLAN2	INV01982030	12/30/2024
QTY	ITEM	DESCRIPTION		UNIT PRICE	AMOUNT
4	HPMCLT-6L	Harrell's ProtectMAX Chlorothalonil 6 L 2.5 Gal (HA) (FP) Not regulated by the DOT for ground transportation. If shipped otherwise, consult MSDS/SDS.		\$140.00	\$560.00

**TERMS AND CONDITIONS**

I understand that Harrell's General Terms and Conditions of Sale, as they may be amended from time-to-time, (the "Terms and Conditions") are incorporated herein by reference as if fully set forth herein. The Terms and Conditions can be located on Harrell's website (www.harrells.com). In the event of a direct conflict between a specific term of this Invoice and the Terms and Conditions, the specific term of this Invoice shall prevail.

**SHIPPING ADDRESS**

Ship-to Acct Number: EAGLAN2  
 EAGLE LANDING GOLF CLUB  
 3989 OAK LANDING PLANTATION  
 Jon Roe  
 ORANGE PARK, FL 32065  
 UNITED STATES OF AMERICA

SUBTOTAL	\$560.00
TAX/STATE FEES	\$0.00
<b>TOTAL</b>	<b>\$560.00</b>

# CYLINDER RENTAL INVOICE

PLEASE MAKE CHECKS PAYABLE TO  
AND MAIL TO

HELGET GAS PRODUCTS  
4211 S 102ND STREET  
OMAHA NE 68127  
[866] 814-1554

HELGET GAS PRODUCTS  
P.O. BOX 30197  
OMAHA NE 68103-1297  
[866] 814-1554

INVOICE
0002293010
PAGE NUMBER
1
INVOICE DATE
12/31/24
CUSTOMER
19888
BRANCH
000730
TERMS
NET 30

B EAGLE LANDING CAFE & VILLAGE STORE  
L SOUTH VILLAGE COMMUNITY DEVELOPMENT  
L 3975 EAGLE LANDING PKWY  
T ORANGE PARK FL 32065  
O

S EAGLE LANDING CAFE & VILLAGE STORE  
H 3975 EAGLE LANDING PKWY  
O ORANGE PARK FL 32065  
T  
O

INVOICE TYPE	ITEM	INVOICE DATE	INVOICE	BEGINNING BALANCE	SHIPPED	RETURNED	ENDING BALANCE	LEASED CYLINDERS	BALANCE	CYLINDER RATE	EXTENDED AMOUNT	
R	I20 20# CYL			6	0	0	6	0	6	8.94	53.64	
R	IK K CYL			1	0	0	1	0	1	8.81	8.81	
<p>MANAGE YOUR ACCOUNT PAY YOUR INVOICES PLACE AN ORDER ALL ONLINE AT: <a href="http://www.helgetgas.com">www.helgetgas.com</a></p> <p style="text-align: center; font-size: 2em; font-family: cursive;">240-7740</p> <p style="text-align: center; font-size: 2em; font-family: cursive;">8</p> <p style="text-align: center; font-size: 2em; font-family: cursive;">1/7/25</p>												
										TAX:	.00	
INVOICE TYPE		TOTAL VALUE OF CYLINDERS								<b>TOTAL</b>		62.45
R - RENTAL												
D - DEMURRAGE												





Commercial Account



Remit payment and make checks payable to: HOME DEPOT CREDIT SERVICES DEPT. 32 - 2539293211 PO BOX 9001043 LOUISVILLE, KY 40290-1043

# INVOICE DETAIL

BILL TO:  
Acct: 6035 3225 3929 3211  
SOUTH VILLAGE CDD

Amount Due:	Trans Date:	DUE DATE:	Invoice #:
\$309.00	11/18/24	01/31/25	4022049
PO: TENNIS		Store: 6935, MIDDLEBURG, FL	

PRODUCT	SKU #	QUANTITY	UNIT PRICE	TOTAL PRICE
HDX 27 GALLON TOUGH TOTE	00002075850001600002	1.0000 EA	\$9.98	\$9.98
HDX 27 GALLON TOUGH TOTE	00002075850001600002	1.0000 EA	\$9.98	\$9.98
HDX 27 GALLON TOUGH TOTE	00002075850001600002	1.0000 EA	\$9.98	\$9.98
6.5 FT FESTIVE PINE T2	10071244410001200010	1.0000 EA	\$49.98	\$49.98
6.5 FT FESTIVE PINE T2	10071244410001200010	1.0000 EA	\$49.98	\$49.98
HDX 27 GALLON TOUGH TOTE	00002075850001600002	1.0000 EA	\$9.98	\$9.98
6.5 FT FESTIVE PINE T2	10071244410001200010	1.0000 EA	\$49.98	\$49.98
DISCOUNT	00000000000000000005	1.0000 EA	-\$0.10	-\$0.10
6.5 FT FESTIVE PINE T2	10071244410001200010	1.0000 EA	\$49.98	\$49.98
UNB (60W) A19 SMT DL 16PK NDIM	10087778580000100035	1.0000 PK	\$19.97	\$19.97
UNB (60W) A19 SMT DL 16PK NDIM	10087778580000100035	1.0000 PK	\$19.97	\$19.97
MKE SHOCKWAVE 1/8"X3-1/2	10053983860000700008	1.0000 EA	\$4.67	\$4.67
CARBIDE BIT				
MKE SHOCKWAVE 1/8"X3-1/2	10053983860000700008	1.0000 EA	\$4.67	\$4.67
CARBIDE BIT				
ASOTV OVER LITE ULTRA	10044442020000100025	1.0000 EA	\$19.98	\$19.98

Purchased by: SWENSON SCOTT  
Customer #: 00002

SUBTOTAL	\$309.00
TAX	\$0.00
TOTAL	\$309.00

*60-7450  
8  
11/18*

50112E

BILL TO:  
Acct: 6035 3225 3929 3211  
SOUTH VILLAGE CDD

Amount Due:	Trans Date:	DUE DATE:	Invoice #:
\$184.40	11/19/24	01/31/25	3011665
PO: TANSTONE		Store: 6890, JACKSONVILLE, FL	

PRODUCT	SKU #	QUANTITY	UNIT PRICE	TOTAL PRICE
SHELF BRACKET_LD_5' X 6'_WH	00007066050000400014	1.0000 EA	\$1.93	\$1.93
SHELF BRACKET_LD_5' X 6'_WH	00007066050000400014	1.0000 EA	\$1.93	\$1.93
SHELF BRACKET_LD_5' X 6'_WH	00007066050000400014	1.0000 EA	\$1.93	\$1.93
SHELF BRACKET_LD_5' X 6'_WH	00007066050000400014	1.0000 EA	\$1.93	\$1.93
22' MULTI POSITION LADDER 300LB DUTY	10048876070000800008	1.0000 EA	\$239.00	\$239.00
SHELF BRACKET_LD_5' X 6'_WH	00007066050000400014	1.0000 EA	\$1.93	\$1.93
DISCOUNT	00000000000000000005	1.0000 EA	-\$90.00	-\$90.00
SHELF BRACKET_LD_5' X 6'_WH	00007066050000400014	1.0000 EA	\$1.93	\$1.93
USG AP LIGHT DUST CONTROL 3.5QT PAIL	10013921510001200003	1.0000 EA	\$10.88	\$10.88
MD 81" VYL CLAD REPL WS-BGE	00005974630000400009	1.0000 EA	\$6.47	\$6.47
MD 81" VYL CLAD REPL WS-BGE	00005974630000400009	1.0000 EA	\$6.47	\$6.47

Purchased by: SWENSON SCOTT  
Customer #: 00002

SUBTOTAL	\$184.40
TAX	\$0.00
TOTAL	\$184.40

*60-7450  
8  
11/19*

BILL TO:  
Acct: 6035 3225 3929 3211  
SOUTH VILLAGE CDD

Amount Due:	Trans Date:	DUE DATE:	Invoice #:
\$227.09	11/19/24	01/31/25	3012490
PO: GOLF		Store: 6935, MIDDLEBURG, FL	

PRODUCT	SKU #	QUANTITY	UNIT PRICE	TOTAL PRICE
6-1/2" STEEL T-POST 1.25	00001755440001300004	1.0000 EA	\$8.21	\$8.21
#036 SS CLAMP 1-3/4"X2-3/4" DIA	00001004940000600024	1.0000 EA	\$3.18	\$3.18
#036 SS CLAMP 1-3/4"X2-3/4" DIA	00001004940000600024	1.0000 EA	\$3.18	\$3.18
#036 SS CLAMP 1-3/4"X2-3/4" DIA	00001004940000600024	1.0000 EA	\$3.18	\$3.18
1X10 PIPE	00003013370000100006	1.0000 EA	\$35.51	\$35.51
1X10 PIPE	00003013370000100006	1.0000 EA	\$35.51	\$35.51

continued →





Commercial Account



Remit payment and make checks payable to:  
HOME DEPOT CREDIT SERVICES  
DEPT. 32 - 2539293211  
PO BOX 9001043  
LOUISVILLE, KY 40290-1043

# INVOICE DETAIL

*Capital Resource  
Supplies  
Landscape  
\$227.09*

Invoice #:  
**3012490**  
continued

PRODUCT	SKU #	QUANTITY	UNIT PRICE	TOTAL PRICE
6-1/2" STEEL T-POST 1.25	00001755440001300004	1.0000 EA	\$8.21	\$8.21
1IN GAL TEE	00001819430000100007	1.0000 EA	\$6.30	\$6.30
DISCOUNT	0000000000000000000005	1.0000 EA	-\$6.00	-\$6.00
1" GALVZDCAP	00001820280000100007	1.0000 EA	\$4.32	\$4.32
1IN GALPLUG	00001820870000100007	1.0000 EA	\$4.69	\$4.69
PINE-SOL ORIGINAL 80OZ.	10108862420000400004	1.0000 EA	\$14.98	\$14.98
PINE-SOL ORIGINAL 80OZ.	10108862420000400004	1.0000 EA	\$14.98	\$14.98
13' BN EDGELIT 3CCT LED FM 2 PACK	10033341780001600003	1.0000 EA	\$69.97	\$69.97
ENERGIZER MAX AA 36-PACK	00005534710003600002	1.0000 EA	\$20.87	\$20.87

Purchased by: SWENSON SCOTT  
Customer #: 00002

<b>SUBTOTAL</b>	\$227.09
<b>TAX</b>	\$0.00
<b>TOTAL</b>	\$227.09

90112E

BILL TO:  
Acct: 6035 3225 3929 3211  
SOUTH VILLAGE CDD

Amount Due:	Trans Date:	DUE DATE:	Invoice #:
\$108.37	11/20/24	01/31/25	<b>2012568</b>
PO: POOL		Store: 6935, MIDDLEBURG, FL	

PRODUCT	SKU #	QUANTITY	UNIT PRICE	TOTAL PRICE
3/4X10 PIPE	00003013290000100006	1.0000 EA	\$32.28	\$32.28
3/4 GAL CPLG	00001818700000100007	1.0000 EA	\$3.72	\$3.72
3/4X10 PIPE	00003013290000100006	1.0000 EA	\$32.28	\$32.28
1 1/2 IN.SPLIT RING-KEYRING	00001418280000500003	1.0000 EA	\$1.97	\$1.97
SS316 STAR DECK SCREW 10X3 1LB	10075912520000300003	1.0000 EA	\$29.98	\$29.98
R510 RGD 2-HOLE STRAP 3/4" PK10	00002861910000800007	1.0000 EA	\$4.98	\$4.98
U-BOLT ZINC 1/4 X 2-5/16 1PC	00001179790001200022	1.0000 EA	\$1.58	\$1.58
U-BOLT ZINC 1/4 X 2-5/16 1PC	00001179790001200022	1.0000 EA	\$1.58	\$1.58

Purchased by: SWENSON SCOTT  
Customer #: 00002

<b>SUBTOTAL</b>	\$108.37
<b>TAX</b>	\$0.00
<b>TOTAL</b>	\$108.37

*Capital Resource  
Supplies  
Landscape  
Birds  
\$108.37*

BILL TO:  
Acct: 6035 3225 3929 3211  
SOUTH VILLAGE CDD

Amount Due:	Trans Date:	DUE DATE:	Invoice #:
-\$86.33	11/20/24	01/31/25	<b>2112552</b>
PO: GOLF		Store: 6935, MIDDLEBURG, FL	

PRODUCT	SKU #	QUANTITY	UNIT PRICE	TOTAL PRICE
1" GALVZDCAP	00001820280000100007	1.0000 EA	-\$4.32	-\$4.32
1IN GAL TEE	00001819430000100007	1.0000 EA	-\$6.30	-\$6.30
1IN GALPLUG	00001820870000100007	1.0000 EA	-\$4.69	-\$4.69
1X10 PIPE	00003013370000100006	1.0000 EA	-\$35.51	-\$35.51
1X10 PIPE	00003013370000100006	1.0000 EA	-\$35.51	-\$35.51

Customer #: 00002

<b>SUBTOTAL</b>	-\$86.33
<b>TAX</b>	\$0.00
<b>TOTAL</b>	-\$86.33

*Capital Resource  
Supplies  
Landscape  
Birds  
-\$86.33*







Commercial Account



Remit payment and make checks payable to:  
HOME DEPOT CREDIT SERVICES  
DEPT. 32 - 2539293211  
PO BOX 9001043  
LOUISVILLE, KY 40290-1043

# INVOICE DETAIL

Invoice #:  
**9013952**  
continued

PRODUCT	SKU #	QUANTITY	UNIT PRICE	TOTAL PRICE
DISCOUNT	00000000000000000000	1.0000	-\$50.00	-\$50.00

Purchased by: SWENSON SCOTT  
Customer #: 00002

<b>SUBTOTAL</b>	\$341.69
<b>TAX</b>	\$0.00
<b>TOTAL</b>	\$341.69

BILL TO:  
Acct: 6035 3225 9929 3211  
SOUTH VILLAGE CDD

<b>Amount Due:</b>	<b>Trans Date:</b>	<b>DUE DATE:</b>	<b>Invoice #:</b>
\$271.33	12/04/24	02/28/25	<b>8014079</b>
<b>PO: GOLF</b>		<b>Store: 6935, MIDDLEBURG, FL</b>	

PRODUCT	SKU #	QUANTITY	UNIT PRICE	TOTAL PRICE
1 PVC CPLG	00001880850000100003	1.0000 EA	\$0.87	\$0.87
1 PVC CPLG	00001880850000100003	1.0000 EA	\$0.87	\$0.87
36" WATER METER VALVE KEY	10050483790000700009	1.0000 EA	\$19.98	\$19.98
1 PVC CPLG	00001880850000100003	1.0000 EA	\$0.87	\$0.87
1 PVC CPLG	00001880850000100003	1.0000 EA	\$0.87	\$0.87
AMERIGAS PROPANE EXCHANGE	00006003720002200004	7.0000 EA	\$21.98	\$153.86
GREAT STUFF GAPS & CRACKS	00001381420000400005	1.0000 EA	\$4.38	\$4.38
12OZ				
1"X 10' PVC40 PE PIPE	00001937550000100002	1.0000 EA	\$8.48	\$8.48
PLC 59W 8FT T8 COOL WHITE 1PK	00004003480000100036	1.0000 EA	\$16.98	\$16.98
PLC 59W 8FT T8 COOL WHITE 1PK	00004003480000100036	1.0000 EA	\$16.98	\$16.98
PLC 59W 8FT T8 COOL WHITE 1PK	00004003480000100036	1.0000 EA	\$16.98	\$16.98
PLC 59W 8FT T8 COOL WHITE 1PK	00004003480000100036	1.0000 EA	\$16.98	\$16.98
8 OZ. RAIN R SHINE PURPLE PRIMER HAN	10048627370000100021	1.0000 EA	\$13.23	\$13.23

Purchased by: SWENSON SCOTT  
Customer #: 00002

<b>SUBTOTAL</b>	\$271.33
<b>TAX</b>	\$0.00
<b>TOTAL</b>	\$271.33

BILL TO:  
Acct: 6035 3225 3929 3211 1460-000 -200  
SOUTH VILLAGE CDD 1470-000 200

<b>Amount Due:</b>	<b>Trans Date:</b>	<b>DUE DATE:</b>	<b>Invoice #:</b>
\$343.48	12/06/24	02/28/25	<b>6014288</b>
<b>PO: GOLF</b>		<b>Store: 6935, MIDDLEBURG, FL</b>	

PRODUCT	SKU #	QUANTITY	UNIT PRICE	TOTAL PRICE
BRASS 69 KEY MASTER PADLOCK	00005333450000500003	1.0000 EA	\$3.97	\$3.97
BRASS 69 KEY MASTER PADLOCK	00005333450000500003	1.0000 EA	\$3.97	\$3.97
BRASS 69 KEY MASTER PADLOCK	00005333450000500003	1.0000 EA	\$3.97	\$3.97
BRASS 69 KEY MASTER PADLOCK	00005333450000500003	1.0000 EA	\$3.97	\$3.97
AMERIGAS PROPANE EXCHANGE	00006003720002200004	6.0000 EA	\$21.98	\$131.88
BRASS 69 KEY MASTER PADLOCK	00005333450000500003	1.0000 EA	\$3.97	\$3.97
1X2X8 FVRR	00001609540000500011	10.0000 EA	\$1.57	\$15.70
BRASS 69 KEY MASTER PADLOCK	00005333450000500003	1.0000 EA	\$3.97	\$3.97
TEKS LATH SHARP PT SCREW 8X1 170PK	00001851750000300006	1.0000 EA	\$12.77	\$12.77
WISE GRIP LEVER DIVERTER HANDLE	00003442830000700002	1.0000 EA	\$9.37	\$9.37
CE WALL PACK LIGHT 1450L	10111823650001800008	1.0000 EA	\$49.97	\$49.97
FEIT 5" LED LS D2D WALL PK 5CCT BZ	10111842390001800016	1.0000 EA	\$99.97	\$99.97

Purchased by: SWENSON SCOTT  
Customer #: 00002

<b>SUBTOTAL</b>	\$343.48
<b>TAX</b>	\$0.00
<b>TOTAL</b>	\$343.48

90112E





Commercial Account



Remit payment and make checks payable to:  
HOME DEPOT CREDIT SERVICES  
DEPT. 32 - 2539293211  
PO BOX 9001043  
LOUISVILLE, KY 40290-1043

# INVOICE DETAIL

**BILL TO:**  
Acct: 6035 3225 3929 3211  
SOUTH VILLAGE CDD

Amount Due:	Trans Date:	DUE DATE:	Invoice #:
\$67.86	12/06/24	02/28/25	6014289
PO: GOLF		Store: 6935, MIDDLEBURG, FL	

PRODUCT	SKU #	QUANTITY	UNIT PRICE	TOTAL PRICE
6 OUTLET PWR STRIP 4' RT ANGLE	0000335884000300005	1.0000 EA	\$7.88	\$7.88
7 FT. CANDY	1011184393000120002	1.0000 EA	\$79.00	\$79.00
DISCOUNT	0000000000000000005	1.0000 EA	-\$19.02	-\$19.02

Purchased by: SWENSON SCOTT  
Customer #: 00002

<b>SUBTOTAL</b>	\$67.86
<b>TAX</b>	\$0.00
<b>TOTAL</b>	\$67.86

**BILL TO:**  
Acct: 6035 3225 3929 3211  
SOUTH VILLAGE CDD

Amount Due:	Trans Date:	DUE DATE:	Invoice #:
\$72.97	12/10/24	02/28/25	2013358
PO: GYM		Store: 6890, JACKSONVILLE, FL	

PRODUCT	SKU #	QUANTITY	UNIT PRICE	TOTAL PRICE
ANGLE SLD STL 48X1 1/2X3/16	00004776740000400002	1.0000 EA	\$35.47	\$35.47
GREY FLECK RUBBER GYM FLOOR 26 IN X3	10059356030000200028	1.0000 LF	\$6.25	\$6.25
GREY FLECK RUBBER GYM FLOOR 26 IN X3	10059356030000200026	4.0000 LF	\$6.25	\$25.00
GREY FLECK RUBBER GYM FLOOR 26 IN X3	10059356030000200028	1.0000 LF	\$6.25	\$6.25

Purchased by: SWENSON SCOTT  
Customer #: 00002

<b>SUBTOTAL</b>	\$72.97
<b>TAX</b>	\$0.00
<b>TOTAL</b>	\$72.97

601129



REPRINT OF ORIGINAL INVOICE

10000

THANKS FOR YOUR ORDER  
IF YOU HAVE ANY QUESTIONS  
OR PROBLEMS, JUST CALL US

FOR CUSTOMER SERVICE ORDER: (888) 263-3423  
FOR ACCOUNT INQUIRIES: (800) 721-6592

Federal ID # 88-2161688

INVOICE NUMBER	AMOUNT DUE	PAGE NUMBER
389897387001	25.90	1 OF 1
INVOICE DATE	TERMS	PAYMENT DUE
03-OCT-24	Net 30	03-NOV-24

**Bill To:** ATTN: ACCTS PAYABLE  
EAGLE LANDING GOLF COURSE  
3989 EAGLE LANDING PKWY  
ORANGE PARK FL 32065-2641  
@@@@@@@@@@@@@@@@@@

**Ship To:** EAGLE LANDING GOLF COURSE  
3989 EAGLE LANDING PKWY  
ORANGE PARK FL 32065-2641

ACCOUNT NUMBER	ACCOUNT MANAGER	SHIP TO ID	ORDER NUMBER	ORDER DATE	SHIPPED DATE		
15779562	Depot, Office	3989EAGLELAND INGPKWY	389897387001	02-OCT-24	03-OCT-24		
BILLING ID	PURCHASE ORDER	RELEASE	ORDERED BY	DESKTOP	COST CENTER		
21782146			JOE HALIFKO				
CATALOG ITEM # / MANUF CODE	DESCRIPTION / CUSTOMER ITEM #	U/M TAX	QTY ORD	QTY SHIP	QTY B/O	UNIT PRICE	EXTENDED PRICE
9995053 244463	Decor, Halloween, Fabric, B 9995053	EA Y	1	1	0	24.090	24.09
500-7245 Member Relations 25.90 OK to Pay JH							
						SUB-TOTAL	24.09
						TIERED DISCOUNT	0.00
						DELIVERY	0.00
						MISCELLANEOUS	0.00
						SALES TAX	1.81
						TOTAL	25.90

To return supplies, please repack in original box and insert our packing list, or copy of this invoice. Please note problem so we may issue credit or replacement, whichever you prefer. Please do not ship collect. Please do not return furniture or machines until you call us first for instructions. Shortage or damage must be reported within 8 days after delivery.

▲ DETACH HERE ▲

CUSTOMER NAME	BILLING ID	INVOICE NUMBER	INVOICE DATE	INVOICE AMOUNT	AMOUNT ENCLOSED
EAGLE LANDING GO LF COURSE	21782146	389897387001	03-OCT-24	25.90	

FLO 217821461 3898973870011 00000002590 1 1



**Invoice**



<b>DATE</b>	<b>INVOICE #</b>
12/3/2024	5106138-IN

**\*ATTENTION NEW REMIT TO\***

<b>Bill To:</b>  Eagle Landing 3989 EAGLE LANDING PKWY ORANGE PARK, FL 32065  Customer Number: 0023507	<b>Ship To:</b>  Eagle Landing 3989 EAGLE LANDING PKWY ORANGE PARK, FL 32065
--	--

<b>Customer P.O.</b> F24 12/1/24	<b>Terms</b> Net 60	<b>NDC Date</b> 12/4/2024	<b>Ship VIA</b> IED	<b>F.O.B.</b> Shanghai
-------------------------------------	------------------------	------------------------------	------------------------	---------------------------

Quantity	Item Code	Description	Price Each	Amount
12	GA904	Mid-crown silhouette (GA904-TMS01002) Khaki Heather, White	15.47	185.64
12	GA904	Mid-crown silhouette (GA904-TMS01002) Steel Heather, White	15.47	185.64
12	GA904	Mid-crown silhouette (GA904-TMS04001) Black	15.47	185.64
12	GA904	Mid-crown silhouette (GA904-TMS01002) Navy, White	15.47	185.64
1	SHIPPINGT	Shipping and Tariff Charges	47.52	47.52

Invoiced by Leslie Platt  
 2275-000 849.12  
 1320-000 .20

~~1320-100~~  
 E98  
 [Signature]  
 12/3/24

All discrepancies with product must be addressed within 14 days of receiving.

Total Pieces: 49

<b>Remit Payment To:</b> Pukka LLC   PO Box 876719   Kansas City, MO 64187-8719 Phone: 419-429-7808   Sales Rep: Chandler Altman	Net Invoice: 790.08 Sales Tax: 59.24  Invoice Balance: 849.32
--	--



EAGLE LANDING GOLF CLUB  
3989 EAGLE LANDING PKWY  
ORANGE PARK FL 32065-2641



SYSCO JACKSONVILLE, INC.  
1501 LEWIS INDUSTRIAL DRIVE  
JACKSONVILLE, FL 32254  
1-800-797-2627 (1-800 SYSCO CS)

904-637-0648

EAGLE LANDING GOLF CLUB  
3989 EAGLE LANDING PKWY  
ORANGE PARK FL 32065 -2641

CUSTOMER'S ORIGINAL INVOICE CONFIDENTIAL PROPERTY OF SYSCO

DELV. DATE	CUSTOMER	INVOICE NUMBER	PAGE	
12/28/24	784966	583022673	3	3
TRUCK STOP	621/003			
ROUTE	6637	PURCHASE ORDER		
TERMS - PAST DUE BALANCES ARE SUBJECT TO SERVICE CHARGE				
Net 30				
MANIFEST# 1275803 NORMAL DELIVERY				
MA: TVADC SCARLETT BAYLESS				

DRIVER:

DOC	QTY	PACK	SIZE	ITEM DESCRIPTION	ITEM CODE	UNIT PRICE	UNIT TAX AMOUNT	EXTENDED PRICE	T	P	INVOICE ADJUSTMENTS	
											CODE	QTY
D	1	CS	15 GAL	COCACOL SYRUP COKE DIET 5X1 BIB	04240010	4273546	105.40	105.40				
D	1	CS	15 GAL	MINMAID SYRUP LEMONADE BIB	16760010	8856122	105.40	105.40				
D	1	CS	15 GAL	SPRITE SYRUP SPRITE 5X1 BIB	09560010	4090395	105.40	105.40				
				GROUP TOTAL****				421.60				
				MISC CHARGES				11.21-	*			
				ALLOWANCE FOR DROP SIZE				8.00				
				CHGS FOR FUEL SURCHARGE								
ORDER SUMMARY				: 2742449								
											1460-000	-20.76
											1470-000	20.76

*[Handwritten signature]*  
12/31/24

000  
240-1340=129152  
200-5500=20.76  
100-7450=227.75  
Total=1540.03

CASES	SPLIT	TOT. PCS	CUBE	GROSS WT.	OPEN: 7:00 AM	CLOSE: 5:00 PM	REMIT TO	SUB TOTAL
3		3	2.6	151			SYSCO JACKSONVILLE 1501 LEWIS INDUSTRIAL DR JACKSONVILLE, FL 32254	1540.03
30	9	39	39.5	822				TAX TOTAL
DRIVER'S SIGN								INVOICE TOTAL
NO. PCS DELVD.								1540.03
CUST. SIGNED INVOICE EVIDENCE OF ALL ITEMS SIGN <b>X</b>								
NO. PCS REC.								
IMPORTANT FACT PROVISION: THE PERISHABLE AGRICULTURAL COMMODITIES LISTED ON THIS INVOICE ARE SUBJECT TO THE STATUTORY TRUST ESTABLISHED BY SECTION 5 (C) OF THE PERISHABLE AGRICULTURAL COMMODITIES ACT 1930 (U.S.C. 499(C)). THE SELLER OF THIS COMMODITY RESERVES A TRUST CLAIM OVER THESE COMMODITIES, AND INVENTORIES OF FOOD OR OTHER PRODUCTS DERIVED FROM THESE COMMODITIES, AND ANY RECEIVABLES OR PROCEEDS FROM THE SALE OF THESE COMMODITIES UNTIL FULL PAYMENT IS RECEIVED. FURTHER, YOU AGREE WITH RESPECT TO ANY DISPUTE ARISING OUT OF YOUR RECEIPT OF THESE PRODUCTS/SERVICES: YOU ARE GIVING UP YOUR RIGHT TO SERVE IN ANY REPRESENTATIVE CAPACITY, OR TO PARTICIPATE AS A MEMBER OF A CLASS OF CLAIMANTS, IN ANY LAWSUIT INVOLVING ANY SUCH DISPUTE.								PAYABLE ON OR BEFORE
								1/27/25
								LAST PAGE

EQUAL OPPORTUNITY AND AFFIRMATIVE ACTION CLAUSES OF 41 CFR 60-1.4, 60-250.4 AND 60-714.4 ARE INCORPORATED HEREIN BY REFERENCE



CUSTOMER'S ORIGINAL INVOICE CONFIDENTIAL PROPERTY OF SYSCO

EAGLE LANDING GOLF CLUB  
3989 EAGLE LANDING PKWY  
ORANGE PARK FL 32065-2641



SYSCO JACKSONVILLE, INC.  
1501 LEWIS INDUSTRIAL DRIVE  
JACKSONVILLE, FL 32254  
1-800-797-2627 (1-800 SYSCO CS

904-637-0648

EAGLE LANDING GOLF CLUB  
3989 EAGLE LANDING PKWY  
ORANGE PARK FL 32065 -2641

DELV. DATE	CUSTOMER	INVOICE NUMBER	PAGE
12/28/24			
TRUCK STOP	784966	583022673	3 2
621/003			
ROUTE	PURCHASE ORDER		
6637	TERMS -PAST DUE BALANCES ARE SUBJECT TO SERVICE CHARGE		
	Net 30		
	MANIFEST# 1275803 NORMAL DELIVERY		
	MA: TVADC SCARLETT BAYLESS		

DRIVER:

QTY	PACK	SIZE	ITEM DESCRIPTION	ITEM CODE	UNIT PRICE	UNIT TAX AMOUNT	EXTENDED PRICE	INVOICE ADJUSTMENTS	
								CODE	QTY
D 1S	ONLY1 GAL	CASACLS	PEPPER JALAPENO SLICES 12730720211	8426330	12.17		12.17		
D 1 CS	41 GAL	SWTBABY	SAUCE SWEET CHILI & WING SJ2347HF	3369354	73.03		73.03		
D 1 CS	104 LB	SYS CLS	SUGAR GRANULATED XFINE CANE 412006	2926727	41.30		41.30		
D 3 CS	4016.9OZ	NIAGARA	WATER BOTTLED SPRING	9901031	13.73		41.19		
D 1 CS	612 CT	TAC MEX	WRAP TORTILLA GR1C HERB 12 195210	8031852	23.16		23.16		
			GROUP TOTAL****				316.53		
			***PAPER & DISP***						
D 1 CS	2500CT	SYS CLS	BAG PLAS RECLOSE SNDW 6.5X 304985452	7863345	30.11		30.11		
D 1 CS	5006 IN	SYSTRNZ	CONTAINER FOAM HNG SDWC YTH1S080ADEC	7336805	37.04		37.04		
D 1 CS	1509X9X3	SYS CLS	CONTAINER FOAM HNG 1C D YTD199S10000	7551334	21.02		21.02		
D 2 CS	2025 CT	DART	CUP FOAM TALL 20 OZ 20J16	4088886	27.56		55.12		
D 1 CS	10060 GALS	SYS REL	LINER REPRO 38X58 1.5 ML X7658AKSX01	1763846	41.77		41.77		
D 1 CS	16250CT	SYS CLS	TOWEL MULTIFOLD 9.4X9.2 WHT 4458693	4458693	42.69		42.69		
			GROUP TOTAL****				227.75		
			***PRODUCE***						
C 2S	ONLY6 CT	SYFPNAT	LETTUCE ICEBERG TRIMMED FRESH	1675610	9.96		19.92		
C 1 CS	148 CT	PACKER	LIME FRESH	1079425	20.76		20.76		
C 2S	ONLY10 LB	IMPFRSH	ONION YELLOW JUMBO FRESH SACK	7201992	9.07		18.14		
C 1S	ONLY5 LB	IMPFRSH	ORANGE BAGGED FRESH 10889356163020	7289526	9.23		9.23		
C 2S	ONLY16 OZ	DRISCOL	STRAWBERRY FRESH DRISCOLL	7582505	7.40		14.80		
			GROUP TOTAL****				82.85		
			***DISPENSER BEVERAGE***						
D 1 CS	15 GAL	COCACOL	SYRUP COKE CLASSIC SX1 BIB 04250010	4090593	105.40		105.40		

CASES	SPLIT	TOT. PCS	CUBE	GROSS WT.	OPEN: 7:00 AM	CLOSE: 5:00 PM	REMIT TO	
15	8	23	28.6	450			SYSCO JACKSONVILLE 1501 LEWIS INDUSTRIAL DR JACKSONVILLE, FL 32254	SUB TOTAL 1227.04
DRIVER'S SIGN	NO. PCS DELVD.	CUST. SIGNED INVOICE EVIDENCE OF ALL ITEMS SIGN	NO. PCS REC.					TAX TOTAL
		X						INVOICE TOTAL
IMPORTANT FACT PROVISION: THE PERISHABLE AGRICULTURAL COMMODITIES LISTED ON THIS INVOICE ARE SUBJECT TO THE STATUTORY TRUST AUTHORIZED BY SECTION 5 (C) OF THE PERISHABLE AGRICULTURAL COMMODITIES ACT 1930 (U.S.C. 495(C)). THE SELLER OF THIS COMMODITY RETAINS A TRUST CLAIM OVER THESE COMMODITIES. ALL INVENTORIES OF FOOD OR OTHER PRODUCTS DELIVERED FROM THESE COMMODITIES, AND ANY RECEIVABLES OR PROCEEDS FROM THE SALE OF THESE COMMODITIES UNTIL FULL PAYMENT IS RECEIVED. FURTHER, YOU AGREE WITH RESPECT TO ANY DISPUTE ARISING OUT OF YOUR RECEIPT OF THESE PRODUCTS/SERVICES: YOU ARE GIVING UP YOUR RIGHT TO SERVE IN ANY REPRESENTATIVE CAPACITY, OR TO PARTICIPATE AS A MEMBER OF A CLASS OF CLAIMANTS, IN ANY LITIGATION INVOLVING ANY SUCH DISPUTE.							PAYABLE ON OR BEFORE	
							CONT. ON PAGE 3	

EQUAL OPPORTUNITY AND AFFIRMATIVE ACTION CLAUSES OF 41 CFR 60-1.4, 60-250.4 AND 60-714.4 ARE INCORPORATED HEREIN BY REFERENCE



CUSTOMER'S ORIGINAL INVOICE CONFIDENTIAL PROPERTY OF SYSCO

EAGLE LANDING GOLF CLUB
3989 EAGLE LANDING PKWY
ORANGE PARK FL 32065-2641



SYSCO JACKSONVILLE, INC.
1501 LEWIS INDUSTRIAL DRIVE
JACKSONVILLE, FL 32254
1-800-797-2627 (1-800 SYSCO CS)

904-637-0648

EAGLE LANDING GOLF CLUB
3989 EAGLE LANDING PKWY
ORANGE PARK FL 32065 -2641

Table with columns: DELV. DATE, CUSTOMER, INVOICE NUMBER, PAGE, TRUCK STOP, ROUTE, PURCHASE ORDER. Includes details like 12/28/24, 784966, 583022673, 3, 1, 621/003, 6637, TERMS -PAST DUE BALANCES ARE SUBJECT TO SERVICE CHARGE, Net 30, MANIFEST# 1275803 NORMAL DELIVERY, MA: TVADC SCARLETT BAYLESS.

DRIVER:

Main invoice table with columns: QTY, PACK, SIZE, ITEM DESCRIPTION, ITEM CODE, UNIT PRICE, UNIT TAX AMOUNT, EXTENDED PRICE, INVOICE ADJUSTMENTS. Includes items like BEEF STEAK PHILLY CAB BR, SHRIMP WHT P&D TLOF 16/2, POTATO FRY SWEET 5/16, etc.

Summary table with columns: CASES, SPLIT, TOT. PCS, CUBE, GROSS WT., OPEN: 7:00 AM, CLOSE: 5:00 PM, REMIT TO, TAX TOTAL, INVOICE TOTAL, PAYABLE ON OR BEFORE, CONT. ON PAGE 2.

EQUAL OPPORTUNITY AND AFFIRMATIVE ACTION CHANCES OF 41 CFR 60-1.4, 60-250.4 AND 60-714.4 ARE INCORPORATED HEREIN BY REFERENCE

IMPORTANT NOTICE: THE PERISHABLE AGRICULTURAL COMMODITIES LISTED ON THIS INVOICE ARE SUBJECT TO THE STATUTORY TRUST AUTHORIZED BY SECTION 5 (C) OF THE PERISHABLE AGRICULTURAL COMMODITIES ACT 1930 (U.S.C. 499E(C)). THE SELLER OF THIS COMMODITY RETAINS A TRUST CLAIM OVER THESE COMMODITIES...





# Invoice

TableTop Linen Rental  
898 Bellevue Ave.  
support@tabletoplinen.com  
Daytona Beach, FL 32114 (386)254-3158

EAGLE LANDING GOLF CLUB  
3989 Eagle Landing Parkway  
Orange Park, FL 32065 (904)860-7177

Date	Invoice	Day	Garment Mark	Freq.	Seq	Term	Account	Route
01/08/2025	0134651	Wed		7	30	CHG	1193-00000	7

Line	Item	Empl	Name / Description	Sizes	Qty.	Min.	OFFICE			ROUTE			Total
							Adj. Qty.	Adj. Amt.	Unit Pr.	Ext. Price	Adj. Qty.	Adj. Amt.	
1	FBNPW		NAPKIN WHITE			200	0	\$0.00	\$0.1320	\$26.40	0	\$0.00	\$26.40
2	FBNPW		NAPKIN WHITE			SRC	0	\$0.00	\$2.0000	\$4.00	0	\$0.00	\$4.00
3	DGBAGST		BAG STAND				0	\$0.00	\$0.1000	\$0.20	0	\$0.00	\$0.20
4	FB8585W		TC 85X85 WHITE			90	0	\$0.00	\$1.7600	\$158.40	0	\$0.00	\$158.40
5	FBMESBAG		MESH BAG			10	0	\$0.00	\$0.1000	\$1.00	0	\$0.00	\$1.00
6	DGCARTHAM		CART HAMPER				0	\$0.00	\$5.0000	\$10.00	0	\$0.00	\$10.00
7	TPP		TOTAL PROTECTION PLAN					\$0.00		\$9.80		\$0.00	\$9.80
			Delivery Charge					\$0.00		\$15.70		\$0.00	\$15.70

Total Due	Cur. Bus.	Cur. Bal.	30	60	90	120	Office Adj.:	\$0.00	Subtotal:	\$225.50	Rte. Adj.:	\$0.00
\$581.04	\$193.68	\$387.36	\$0.00	\$0.00	\$0.00	\$0.00	Tax Adj.:	\$0.00	Sales Tax:	\$0.00	Tax Adj.:	\$0.00
Comment: _____							Net Adj.:	\$0.00	Prebill:	\$225.50	Net Adj.:	\$0.00

Total Adj.: \$0.00  
Tax Adj.: \$0.00

Net Charge: **\$225.50**

Received By: \_\_\_\_\_ N 01/08/2025 11:11:54AM

*Handwritten notes:*  
 240-7465 LINEN 225.50  
 1/4/25  
 [Signature]

# DEBIT INVOICE 411427102

INVOICE DATE 01/01/2025  
PAGE 1 OF 1

The Toro Company  
8111 Lyndale Ave. So.  
BLOOMINGTON MN 55420-1196

PO NUMBER Ultimate60	DATE 07/30/2024
DELIVERY	DATE
BILL OF LADING	DATE
ORDER NUMBER 70330034	DATE 07/30/2024

Customer Support Services  
PLEASE REMIT TO:  
THE TORO COMPANY - NSN  
39398 Treasury Center  
CHICAGO IL 60694-9300

CUST#: 963872  
PAYER:  
EAGLE LANDING GOLF CLUB  
ATTN: BRAD STEPHENS  
3989 EAGLE LANDING PARKWAY  
ORANGE PARK FL 32065

CUST#: 963872  
SOLD TO:  
EAGLE LANDING GOLF CLUB  
ATTN: BRAD STEPHENS  
3989 EAGLE LANDING PARKWAY  
ORANGE PARK FL 32065

CUST#: 963872  
SHIP TO:  
EAGLE LANDING GOLF CLUB  
ATTN: BRAD STEPHENS  
3989 EAGLE LANDING PARKWAY  
ORANGE PARK FL 32065

*Cap IRR*  
*1/8/25*  
*ZZ*  
*[Signature]*

SHIPPED VIA: ORDER TYPE: Debit Memo Request CURRENCY: USD  
WAREHOUSE: NSN Abilene Dist-Cent INTL LICENSE: NLR FREIGHT:  
LETTER OF CREDIT NO: ECCN#: EAR99

MATERIAL NO./DESCRIPTION	QTY	UNIT PRICE	ADJUSTMENTS	NET	EXTENSION
ULT-60-EQ MONTHLYEQUIPPMT	93	1.00	0.00	1.00	93.00

Billing Period: 01/01/2025 Thru: 01/31/2025

ULT-60-SVC MONTHLYSUPPMT	189	1.00	0.00	1.00	189.00
-----------------------------	-----	------	------	------	--------

Billing Period: 01/01/2025 Thru: 01/31/2025

PRODUCT TOTAL: 282.00  
INVOICE TOTAL: 282.00

PAYABLE IN: U.S. Dollar  
TERMS: 06 NET 30 DAYS / 30 days inv date  
NET DUE DATE: 01/31/2025

TRACKING#/PRO#/PARS#:

These commodities, technology or software were exported from the United States in accordance with the Export Administration Regulations. Diversion contrary to U.S. law is prohibited.

We hereby certify that these goods were produced in compliance with all applicable requirements of Sections 6, 7, and 12 of the Fair Labor Standards Act, as amended and of regulations and orders of the United States Department of Labor issued under Section 14 thereof.

(ORIGINAL INVOICE)



# Invoice

Reference Nbr.: 007432  
 Date: 30-Dec-2024  
 Due Date: 29-Jan-2025  
 Customer ID: C0000559  
 Master Inv Total: 1,282.61

Trigon Turf Sciences  
**New Address**  
 Department # 5612  
 P.O. Box 25008  
 Bradenton, FL, 34206-5008  
 Phone: 757-220-4466

**TOTAL Invoice: 1,282.61**

**BILL TO:**  
 Eagle Landing Golf Club  
 890 Oakleaf Plantation Pkwy  
 Orange Park FL 32065  
 United States of America

**SHIP TO:**  
 Eagle Landing Golf Club  
 890 Oakleaf Plantation Pkwy  
 Orange Park FL 32065  
 United States of America  
 Attn: Jon Roe

**CUSTOMER REF. NBR.**

**TERMS**  
 Net 30

**CONTACT**  
 Bob Solms

NO.	ITEM	QTY.	UOM	UNIT PRICE	EXTENDED PRICE
1	2704: Ninja Aeration Tines Solids	12.00	PACK	95.00	1,140.00
2	Freight ShipVia	1.00		57.11	57.11

400-7610  
 1/11/2025

*[Handwritten signature]*  
 1/2/25

NOTE:

Tax Total: 85.50

<b>TOTAL Invoice:</b>	1,282.61
<b>Balance Remaining :</b>	1,282.61

ACCOUNT NO: 91221150 INVOICE NO: 01207285 INVOICE DATE: 11/21/10 CUSTOMER NO: 11221100 NUMBER OF COPIES: 3

Bill

To: 30 VILLAGE COMM DEV DISTR  
3989 EAGLE LANDING PKWY  
ORANGE PARK FL 32065

Ship To: TRN EAGLE LANDING PKWY  
3989 EAGLE LANDING PKWY  
ORANGE PARK FL 32065  
904 291 5600  
DEPT # 03

Attn: CHRIS COLLETTI

Order #	Qty	Unit	Product	Description	Package Size	Weight	Price	Unit Price	Extended Price
5425	5	EA	WILLIAMSON BLVD	PORT ORANGE	1000	5000	223.45	1117.25	1117.25

TOTAL NET WT: 1122.37  
TOTAL GROSS WT: 1235.68

INVOICE SUMMARY: 7d PILES SHIPPED

PRODUCT TOTAL \$ 2791.26

Federal Occupational Safety and Health Standards Section 1910.1202 (b) (5) (ii) requires that all manufacturers and distributors of products provide material safety data sheets on non-food products defined to be hazardous products such as cleaning products and pesticides are included in the scope of the standard. In compliance with the law, MSDS are available to our customers and can be obtained by contacting the procurement manager in our district office or by advising your sales representative. You may contact HAZMAT HOTLINE at phone # (800) 424-8802.

This amount is an estimate at time of shipping prior to adjustments made at delivery. 9/21/10

You agree with respect to any dispute arising out of or in connection with this purchase to participate as a member of a class, in a separate or to participate as a member of a class, in a lawsuit also agreed to by US Foods sole option, to submit to binding, individual arbitration of all claims, and such arbitration shall be conducted in accordance with the Federal Arbitration Act, 9 U.S.C. 5.1 and conducted in accordance with the Commercial Rules of the American Arbitration Association and any award shall pay half the costs of arbitration, and separately pay its own attorneys fees and costs. For more information about the fuel surcharge, please visit <https://www.usfoods.com/terms/fuelsurcharge/standardarbitration>.



000  
240-1340 = 2172.10  
240-7444 = 306.74  
500-7444 = 88.97  
500-7456 = 223.45

Total = 2791.26

ACCOUNT NO. INVOICE NO. DATE NO. INVOICE NO. NUMBER

3989 EAGLE LANDING PKWY FL 3989 EAGLE LANDING PKWY FL 3989 EAGLE LANDING PKWY FL

ORANGE PARK 32065  
 SUPPL. COLLETTI

ORANGE PARK 32065  
 904 291 5900  
 DEPT # 08

3989 EAGLE LANDING PKWY FL 3989 EAGLE LANDING PKWY FL 3989 EAGLE LANDING PKWY FL

Ship To: 3989 EAGLE LANDING PKWY FL 3989 EAGLE LANDING PKWY FL 3989 EAGLE LANDING PKWY FL  
 Ship From: 5425 S WILLIAMSON BLVD JUPITER FL 3989 EAGLE LANDING PKWY FL 3989 EAGLE LANDING PKWY FL  
 Product: DRY DEFRIGEST, DSCHM SOLID POWR 0454-SODIUM HYDROXIDE, SOLID, MIX USE  
 Description: DRY DEFRIGEST, DSCHM SOLID POWR 0454-SODIUM HYDROXIDE, SOLID, MIX USE  
 Price: 0700  
 Unit: 500 EA  
 Extended: 350.00

QTY	UNIT	SALES PRICE	PRODUCT NUMBER	DESCRIPTION	FACTOR	LEVEL	WEIGHT	PRICE	UNIT	EXTENDED
1	CS	2840726		DRY DEFRIGEST, DSCHM SOLID POWR 0454-SODIUM HYDROXIDE, SOLID, MIX USE	500 EA			0700	500 EA	350.00
TOTAL HAZARDOUS WEIGHT: 36.00 TOTAL HAZARDOUS PIECES: 1 TOTAL HAZARDOUS CUBE: 0.01										

*chem*

QTY	UNIT	SALES PRICE	PRODUCT NUMBER	DESCRIPTION	FACTOR	LEVEL	WEIGHT	PRICE	UNIT	EXTENDED
1	CS	2840726		DRY DEFRIGEST, DSCHM SOLID POWR 0454-SODIUM HYDROXIDE, SOLID, MIX USE	500 EA			0700	500 EA	350.00
1	EA	0778670		OIL BUTR ALTEH SEVEN SALTIN	500 EA					
1	EA	1004381		WRAF 10 75X10 WAX PAPER WHT	500 EA					
1	CS	1259281		SEASONING SALT, INSTA SHLF	20 LB					
1	CS	1330829		RICE, WASHN RAW IMP FLAND	20 LB					
1	CS	1389113		SHOETININE, FRYG 50YRN LID	20 LB					
1	CS	1714452		DRINK, SODA GNK ALE, GAMDA DRYZAZIO DZ	12/200 EA					
1	CS	2399696		DETERGENT, HOT 5 PAN KML PLS	12/200 EA					
1	CS	3554567		LID, CUP SFLR 2 4 FEAT PLSI	12/200 EA					
1	CS	4959856		TRINK, SODA COIA TRVE CLSF	12/200 EA					
1	CS	4959856		NINSE-ADDITIONAL DSHM DZ8 E-2 5 LI	12/200 EA					
1	EA	5267483		SAUCE, BUFFLO HOT FET PLSI	500 EA					
1	EA	512652		LABEL, FRI 75" DDI 1900 RL	500 EA					
1	CS	5551351		TOHAI, CR33 FL W/TH ICE CMC	500 EA					
1	CS	62292776		GLUVE, VIRYL XL PE CLR 6MKD	10/100 EA					
1	CS	7802522		RETCHEP, THTC FRY 733 RED 50	10/100 EA					
1	CS	79122678		MARKIN, DMKR WMI 1/2X1/2 PLT	20/250 EA					
1	CS	8021818		CLEAMER, GEG R42 LFG 59RAY 1/2	20/250 EA					
1	CS	8260545		SAUCE, HOT GLE5 1/2 SMLR STABL	12/200 EA					
1	CS	92512920		CUP, PET PES 1 1/2 OLB CLR	20/250 EA					
1	CS	93274883		CLEAMER, DISINF-CLER-UP-LAY	50/50 EA					
1	CS	93274883		SAUCE, HOT 5 PAN KML PLS	12/200 EA					
1	EA	0198721		REFRIGERATED CANDY, PNI BULK CUP RSKS	30 EA					
1	EA	1313404		DRESSING, TRT TNG 7 OZ	30 EA					
1	CS	1328547		SQUASH, YELLOW RI TLEJUN FRESH	10 EA					
1	CS	1334113		CUCUMBER, LAST	10 EA					
1	CS	2331353		TOMATO, RND 5X6 RI BRD FRESH	25 LB					

*chem*

*chem*

*500*

*500*

ACCOUNT NO: 71221150  
 INVOICE NO: 0170725  
 DATE: 10/25/94  
 SALES REP: [Name]  
 BUYER: [Name]

Bill To:

50 VILLAGE TOMMY DEY FISH  
 3989 EAGLE LANDING PKWY  
 ORANGE PARK FL 32065  
 CHRIS COLLETTI

Ship To:

3989 EAGLE LANDING PKWY  
 ORANGE PARK FL 32065  
 904 291 5400  
 DEPT 9

Remit To:

AT NTA  
 30384-8421  
 602 1700

SALES REP: SALES 9 WILLIAMSON BLVD  
 NET 21 DAYS  
 ORDERED: [Name]  
 SHIPPED: [Name]  
 Description: [Name]  
 Pack Size: [Name]  
 Label: [Name]  
 Weight: [Name]  
 Pricing: [Name]  
 Unit: [Name]  
 Extended: [Name]

QTY	UNIT	DESCRIPTION	PACK SIZE	WEIGHT	PRICE	EXTENDED
1	EA	CARROT, STICK 2 3/4" FRESH	5 LB	0.2400	0.2400	0.24
0	CS	READY TO EAT - Please Refer				
1	CS	CHICKEN, WING 182J1 JUN RAW	4.10 LB	0.7000	2.8400	2.84
1	CS	CHICKEN, BAST SNEL 6 Z BML	4.5 LB	0.7000	3.1500	3.15
1	CS	BROCCOLI, FLORET MINI ICELS REF 4/3 LB	UNUSS WALT			
2	CS	BEEF, PTY BRND 80/20 2:1 KND	20.8 OZ	0.0900	1.8000	1.80
1	CS	AVOCADO, HALF REF	4.5 LB	0.2000	0.9000	0.90
1	FA	READY TO EAT - Please Refer to Return Policy				
1	FA	CELERY, STICK 4" FRESH REF	4.5 LB	1.5000	1.5000	1.50
1	CS	READY TO EAT - Please Refer to Return Policy				
1	CS	DRESSING, RANCH HNS:1 P ST	4.5 OZ	1.4500	1.4500	1.45
1	CS	READY TO EAT - Please Refer to Return Policy				
1	CS	POTATO, SLOD 1 1/2" SKIN RAW	6.75 LB	0.7100	4.8075	4.81
1	CS	POTATO, SLOD 1 1/2" EXTRA CRSP	6.75 LB	0.7100	4.8075	4.81
1	CS	SALMON, ATLNTD 6 1/4 PTH PBD	30 10 LB	1.6000	48.0000	48.00
1	CS	HOT DOG, AB 6 1/4" RLR GRILL	12 10 LB	0.6000	7.2000	7.20
1	CS	BREAD, PITA DRIG 8" FZN	12/8 EA	0.7000	8.4000	8.40
1	CS	BREAD, WH 1 1/2" SLCD 9 1/2" FZN	12/8 EA	0.7000	8.4000	8.40
1	CS	APPETIZER, CHS MDZ2 BRDD ITLN 4/3 LB	4/3 LB	0.7000	2.8000	2.80
1	CS	ROLL, HOT DUG WH 5" SLCD FZN 4/3 LB	4/3 LB	0.7000	2.8000	2.80
1	CS	BUN, HOT DUG WH 5" SLCD FZN 4/3 LB	4/3 LB	0.7000	2.8000	2.80
1	CS	CHICKEN, WING 182J1 JUN RAW	4.10 LB	0.7000	2.8400	2.84
1	CS	TURKEY, BRST SLICED 5 OZ FZN	12/1 LB	0.8000	9.6000	9.60
1	CS	SOUP, KRDC CHS CNDSD ADD MILK 3/4 LR	MULTI 4.1	0.9100	3.7310	3.73

TOTAL DRY: 17.26  
 TOTAL REFRIGERATED: 48.13  
 TOTAL FROZEN: 1.23

ACCOUNT NO. 91221150 INVOICE NO. F090469 INVOICE DATE 01/07/24 CUSTOMER NO. 11221140 PURCH. ORDER NUMBER 0932 UNDEKED DATE 11/02/23

Bill To: 56 WILLIAMSON COMM DEV CTR 3989 EAGLE LANDING PKWY ORANGE PARK FL 32065

Ship To: TEN EAGLE LANDING BLVD 3989 EAGLE LANDING PKWY ORANGE PARK FL 32065 904 291 5600 DEPT # 01

Ship Via: 5625 S WILLIAMSON BLVD ORANGE FL 32065  
 Order Date: 01/07/24  
 Order Number: 27717  
 Order Type: REFRIGERATED  
 Product: MUSHROOM, SLCU 1/4" CLMD #1 5 Lb  
 Gross Weight: 5.00  
 Pieces Shipped: 1  
 Pieces Ordered: 1

REFRIGERATED  
 MUSHROOM, SLCU 1/4" CLMD #1 5 Lb  
 READY TO EAT - Storage Refer to Lot # 0111  
 STORAGE LOCATION RECAP:IN

TOTAL NET WT: 5.00  
 TOTAL GROSS WT: 5.90  
 TOTAL ORDER: 1  
 TOTAL SHIPPED: 1  
 TOTAL ORDERED: 1  
 TOTAL SHIPPED: 1

This amount is an estimate at time of shipping prior to delivery: \$ 17.24

*[Handwritten Signature]*

000  
~~240~~-1340=17.24

\*\*\*\*\*  
 \* Federal Occupational Safety and Health Standards Section 1910.1200 - H  
 \* Communication requires manufacturers and distributors to provide material  
 \* Safety Data Sheets on non-food products that are to be in various prod  
 \* such as cleaning products and pesticides are included in the scope of the  
 \* standard. In compliance with the law, we have a team of experts who  
 \* customers and can be obtained by contacting the Procurement manager in our  
 \* district office or by advising your sales representative  
 \* You may contact HAZMAT HOTLINE at phone # (800) 424 - 8802  
 \*\*\*\*\*



ACCOUNT NO. 91221150 INVOICE NO. 2237519 INVOICE DATE 01/10/25 CUSTOMER NO. 11221140 PURCHASE ORDER NUMBER SALES LOC. 3055 SALES REP. 0832 DATE ORDERED 01/09/25

Route: 5332 / 7

ORDER NUMBER: 34779

Bill To: SO VILLAGE COMM DEV DISTR 3989 EAGLE LANDING PKWY ORANGE PARK FL 32065  
 Ship To: TRN EAGLE LANDING GLF CLB 3989 EAGLE LANDING PKWY ORANGE PARK FL 32065  
 Remit To: US Foods, Inc. P.O. BOX 198421 ATLANTA GA 30384-8421 336 763 1304  
 Att: CHRIS COLLETTI

Ship From: 5425 S WILLIAMSON BLVD PORT ORANGE FL Ship Date: 01/10/25  
 Terms: NET 21 DAYS Social Instr: DRIVER MUST LEAVE FINAL RECEIPT FOR INV CHANGE  
 Page 03 of 04

Qty Ordered	Qty Shipped	Sales Unit	Product Number	Description	Pack Size	Label	Weight	Pricing Unit	Unit Price	Extended Price
-------------	-------------	------------	----------------	-------------	-----------	-------	--------	--------------	------------	----------------

\*\*\* INVOICE SUMMARY \*\*\*  
 TOTAL NET WGT: 794.90  
 TOTAL GROSS WGT: 863.46  
 PIECES ORDERED: 53  
 PIECES SHIPPED: 53  
 ITEMS SHIPPED: 44

PRODUCT TOTAL \$ 1902.79

\*\*\*\*\*  
 \* Federal Occupation Safety and Health Standards, Section 1910.1200 on Hazard  
 \* Communication requires manufacturers and distributors to provide Material  
 \* Safety Data Sheets on non-food products defined to be hazardous. Products  
 \* such as cleaning products and pesticides are included in the scope of the  
 \* Standard. In compliance with the law, MSDS are available to US Foods, Inc.  
 \* customers and can be obtained by contacting the Procurement Manager in our  
 \* district office or by advising your sales representative.  
 \* You may contact HAZMAT HOTLINE at phone # (800) 424 - 6802.  
 \*\*\*\*\*

TAXABLE AMOUNT \$ 00  
 GEN SALES TAX 2 .00

This amount is an estimate at time of shipping prior to any adjustments made at delivery \$ 1902.79

\*\*\*\*\*  
 \* You agree with respect to any dispute arising out of your purchase from  
 \* US Foods: (i) you are giving up your right to serve in any representative  
 \* capacity, or to participate as a member of a class, in any lawsuit; (ii) you  
 \* also agree, at US Foods sole option, to submit to binding, individual  
 \* arbitration of all claims, (iii) such arbitration shall be governed by the  
 \* Federal Arbitration Act, 9 U.S.C. s.1 and conducted in accordance with the  
 \* Commercial Rules of the American Arbitration Association; and (iv) each party  
 \* shall pay half the costs of arbitration, and separately pay its own attorneys'  
 \* fees and costs. For more information about the fuel surcharge, go to:  
 \* https://www.usfoods.com/terms/fuelsurcharge/StandardEIAAreaLowerAtlantic.h  
 \* tml  
 \* If you have an agreement with US Foods that expressly addresses the  
 \* calculation of the fuel surcharge, please refer to that agreement.  
 \*\*\*\*\*

*Handwritten notes:*  
 1000-1340 = 1777.79  
 500-7450-125.00  
 Total = 1902.79

ACCOUNT INVOICE INVOICE CUSTOMER PURCHASE ORDER  
 NO. NO. DATE NO. NUMBER  
 91221150 2237519 01/10/25 11221140

SALES SALES DATE  
 LOC REP ORDERED  
 3055 0832 01/09/25

Route: 5332 / 7

ORDER NUMBER: 34778

Bill To: 50 VILLAGE COMM DEV DISTR  
 3989 EAGLE LANDING PKWY  
 ORANGE PARK FL  
 32065  
 Attn: CHRIS COLLETTI

Ship To: TRN EAGLE LANDING GLF CLB  
 3989 EAGLE LANDING PKWY  
 ORANGE PARK FL  
 32065  
 904 291 5600  
 DEPT # 00

Rec'd To: US Foods, Inc.  
 P O. BOX 198421  
 ATLANTA GA  
 30384-8421  
 386 763 1304

Ship From: 5425 S. WILLIAMSON BLVD PORT ORANGE FL Ship Date: 01/10/25 Page 01 of 04  
 Terms: NET 21 DAYS Special Instr: DRIVER MUST LEAVE FINAL RECEIPT FOR INV CHANGE

Qty	Qty	Sales	Product	Description	Pack Size	Label	C	Weight	Pricing	Unit	Extended
Ordered	Shipped	Unit	Number				D		Unit	Price	Price
				DRY							
1		EA	0760371	SPICE, ONION GRAN PLST SHKR	20 OZ	MONARCH			EA	7.9200	7.92
2		CS	1328699	SHORTENING, FRYG SOYBN LIQ-CLR	35 LB	HARVEST UL			CS	32.0100	64.02
1		CS	1457016	CUP, SFLE POLYP 2 Z CLR PTN	12/200 EA	DIXIE			CS	41.5200	41.52
1		CS	1681600	FILM, CLING 18"X2000' PLST RL 1 RL		ANCHOR			CS	15.2100	15.21
1		EA	2338382	SPICE, GRNC GRAN SHLF STABL	26 OZ	MCCORMICK			EA	29.8600	29.86
1		CS	2833239	CHIP, ASST SS BAG SHLF STABL	2/30 EA	FRITO LAY			CS	41.0800	41.08
1		CS	3554585	DRINK, SODA COLA COKE CLSC CAN	24/12 OZ	COKE			CS	18.2900	18.29
1		CS	3737327	HONEY, AMBR LIGHT PLST JUG	6/3 LB	MONARCH			CS	28.4500	28.45
1		CS	4073284	SHELL, TACO CORN WHT 5" HARD	8/25 EA	MISSION			CS	25.9000	25.90
1		EA	4353462	SEASONING, TACO NO MSG SHLF	21 OZ	MONARCH			EA	7.7300	7.73
1		CS	5651351	GLOVE, VINYL XL PF CLR AMBX	10/100 EA	VALUGAROS			CS	21.6700	21.67
2		CS	6729776	KETCHUP, TMTD FCY 33% RED SRZ	16/14 OZ	HEINZ			CS	31.2100	62.42
1		CS	7495427	BAG, FOOD STRG 1 GAL 10.5X10.5	250 EA	HANDGARDS			CS	12.5500	12.55
1		CS	7520950	SAUCE, PIZA TMTD CAN SHLF	8/410 CN	PIZZAOLD			CS	41.7900	41.79
1		EA	8003956	SAUCE, TYKI BLAZ PLST JUG SHLF	5 LB	KIKKOMAN			EA	8.9600	8.96
1		CS	9009218	RELISH, PKL SWT SS POUCH	200/9 GR	HEINZ			CS	10.5600	10.56
1		CS	9484734	JUICE, GRPFT RUBY RED 100%	12/15.2 OZ	TROPICANA			CS	20.2900	20.29
1		CS	9664343	CUP, SFLE PLYST 3.25 Z TNSLT	20/125 EA	DART			CS	34.0500	34.05
1		CS	9844416	SAUCE, BBQ PLST JUG SHLF STABL	4/1 GA	SWEET BABY			CS	51.5700	51.57
				REFRIGERATED							
1		CS	0454210	PEPPER, BELL GREEN CHOICE FRESH	5 LB	PACKER			CS	17.5500	17.55
1		CS	2326411	LETTUCE, ICBRG FRESH REF BOX	24 EA	CROSS VALY			CS	28.9100	28.91
1		EA	2348936	CARROT, STICK 3 3/4" FRESH	5 LB	CROSS VALY			EA	6.9400	6.94
				READY TO EAT - Please Refer to Return Policy							
2		CS	2721173	CHICKEN, WING 1&2JT JMB RAW	4/10 LB	PATUXENT			CS	94.1200	188.24
2		CS	2725711	CHICKEN, BRST SHGL 4 Z BMLS	4/5 LB	PATUXENT			CS	29.0500	58.10
1		EA	3587482	CHEESE, PARM GRTD BAG REF IMP	5 LB	ROSELI			EA	26.5900	26.59
2		CS	4284530	PEPPER, BELL RED CHO FRESH REFS	5 LB	PACKER			CS	18.0100	36.02
1		EA	4342010	CARROT, INTSTK SHKO FRESH REF	4/5 LB	CROSS VALY			EA	6.7300	6.73
				READY TO EAT - Please Refer to Return Policy							
2		CS	5327275	BEEF, PTY GRND 86/20 2-1 RND	20/8 OZ	CTLMM SLCY			CS	42.0000	84.00
1		CS	5332546	PICKLE, DILL KO CC CHIP	5 GA	MONARCH			CS	44.9200	44.92
1		CS	6577043	TOMATO, RED RND OGD 3/8"	2/5 LB	CROSS VALY			CS	22.5400	22.54
				READY TO EAT - Please Refer to Return Policy							
1		EA	7331614	CELERY, STICK 4" FRESH REF	4/5 LB	CROSS VALY			EA	10.8300	10.83
				READY TO EAT - Please Refer to Return Policy							

ACCOUNT INVOICE INVOICE CUSTOMER PURCHASE ORDER  
 NO. NO. DATE NO. NUMBER  
 91221150 2237517 01/10/25 11221140

SALES SALES DATE  
 LOC. REF. ORDERED  
 3055 0632 01/09/25

Route: 5332 / 7

ORDER NUMBER: 34778

Bill To: SO VILLAGE COMM DEV DISTR  
 3989 EAGLE LANDING PKWY  
 ORANGE PARK FL  
 32065  
 Att: CHRIS COLLETTI

Ship To: TRN EAGLE LANDING GLF CLB  
 3989 EAGLE LANDING PKWY  
 ORANGE PARK FL  
 32065  
 904 291 5600  
 DEPT # 00

Remit To: US Foods, Inc.  
 P.O. BOX 198421  
 ATLANTA GA  
 30384-9421  
 386 763 1304

Ship From: 5425 S. WILLIAMSON BLVD PORT ORANGE FL Ship Date: 01/10/25 Page 02 of 04  
 Terms: NET 21 DAYS Social Instr: DRIVER MUST LEAVE FINAL RECEIPT FOR INV CHANGE

Qty Ordered	Qty Shipped	Sales Unit	Product Number	Description	Pack Size	Label	C Weight	Pricing Unit	Unit Price	Extended Price
1	1	CS	8432734	GINGER ROOT, FRESH REF	3 LB	PACKER		CS	10.8000	10.80
1	1	CS	9124520	DRESSING, RANCH HMSTY PLST JAR4/1 GA		KEN'S		CS	46.0800	46.08
READY TO EAT - Please Refer to Return Policy										
FROZEN										
1	1	CS	2883130	POTATO, FF SC 3/8" EXTRA CRSPY6/5 LB		MOWARCH		CS	50.1300	50.13
1	1	CS	3330099	HOT DOG, AB 6.1 5" RLR GRIL	10 LB	PATUXENT		CS	30.8600	30.86
1	1	CS	5915319	APPETIZER, CHS MOZZ BRDD	6/2 LB	LAMB WESTN		CS	64.9800	64.98
3	3	CS	6553758	ROLL, KBR WHT 4.5" SLCD BKD	6/8/3.5 OZ	ROTELLA		CS	31.6600	94.98
1	1	CS	6773501	TART, APPL RSTIC 4" SS BKD	3/8/6.3 OZ	CHEFS LINE		CS	52.0100	52.01
1	1	CS	6911663	PANGASIUS, STPED 5-7 Z FIL P8015 LB		HARBOR BHK		CS	39.0800	39.08
1	1	CS	7143605	RICE, VGTRM FRIED CKD BOIL IN 4/3 LB		MINH		CS	39.5000	39.50
2	2	CS	7637713	CHICKEN, TNDLN BTRD FRITR BEER2/5 LB		PATUXENT		CS	39.9600	79.92
1	1	CS	8131864	BEEF, GRND 80/20 FINE RAW FZN 4/5 LB		AVENDRA		CS	86.0000	86.00
1	1	CS	9205147	BEEF, PTY GRND 75/25 3:1 HMSTY60/5.33 OZ		TNTTSTYND		CS	85.0000	85.00
1	1	CS	9870536	CHICKEN, BRST 3.5 Z BRDD HMSTY2/5 LB		TYSON REDL		CS	31.0100	31.01

STORAGE LOCATION RECAP(N)

TOTAL DRY	PIECES ORDERED:	21	PIECES SHIPPED:	21	ITEMS SHIPPED:	19	584.73
TOTAL REFRIGERATED	PIECES ORDERED:	18	PIECES SHIPPED:	18	ITEMS SHIPPED:	14	464.59
TOTAL FROZEN	PIECES ORDERED:	14	PIECES SHIPPED:	14	ITEMS SHIPPED:	11	653.47



Wesco Turf, Inc.  
 2101 Cantu Court  
 Sarasota, FL 34232-6240  
 (941) 377-6777

Invoice# 41246562  
 Location# 02  
 Date 12/30/24  
 Page 1 OF 1

\*\* Invoice \*\*

310428  
 EAGLE LANDING GOLF CLUB  
 ATTN:ACCOUNTS PAYABLE  
 3989 EAGLE LANDING PARKWAY  
 SOUTH VILLAGE CDD  
 ORANGE PARK, FL 32065-3530

Ship To:  
 EAGLE LANDING GOLF COURSE  
 890 OAKLEAF PLANTATION PKWY.  
 SOUTH VILLAGE CDD  
 ORANGE PARK, FL 32065

72\*1

=====  
 CustP/O:JIM 12/30                      Reps :304 /                      Terms:Net 30 Days  
 Ord-Date:12/30/24                      W/B:Dennis Johnson                      Order# :21495556  
 Billed-Date:12/30/24                      Ship-Via:UPS GROUND  
 =====

=====  
 Product                      Description                      Open    Ship'd                      B/O                      Price U/M                      Extension  
 =====

Shipment Tracking Reference : 1Z3436820367744178

66-393-10-S                      PUMP WATER; ASSEMBLY KOHL                      1                      1                      0                      267.000 EA                      267.00  
 KOHL

400 - 7610  
 1/11/2025  
 77

\*\*\*\*\*  
 \*\*\* HOLIDAY CLOSING: ALL LOCATIONS will be closed Jan 1 \*\*\*

Mdse Total	Handling	Misc Chg	Tax	Freight	Dep-amt	Dep-Appld	Invoice Total
267.00	4.50	0.00	0.00	16.64	0.00	0.00	288.14

Important: Acceptance of goods constitutes customer agreement to comply with credit and sales terms and conditions of Wesco Turf, Inc. Shipping errors must be reported within 48 hours of receipt of shipment. Requests for return of merchandise must be made within 30 days of the invoice date. No returns will be accepted without a return goods authorization number. Call customer service to obtain an RGA number. A 15% restocking charge and/or a 10% factory return processing fee will apply according to parts policy. Returns must be in re-salable condition. A finance charge of 1.5% per month will be added to all past due accounts. A \$30 handling fee will be charged on all returned checks. If an account is placed for collection, buyer agrees to pay all costs of collection, including reasonable attorney fees and costs, whether or not suit is brought.



**ACUSHNET COMPANY**  
 P.O. BOX 965 FAIRHAVEN, MA 02719-0965  
 Tel: 800-225-8500 Fax: 508-979-3913



**INVOICE**  
 Currency: USD

Tax No: 04-2591836

<b>Invoice No</b> 919109744		<b>Invoice Date</b> 10/17/24	<b>Shipment Date</b> 10/17/24	<b>Order Date</b> 08/02/24
<b>Order No</b> 3024596877	<b>Whs</b> 05A	<b>Delivery No</b> 58979472	<b>Customer P.O.</b> AT ONCE LADIES	<b>Account No</b> US00027669 \ US00040574

<b>Sold To</b> SOUTH VILLAGE COMMUNITY DEVELOP DISTRICT DBA EAGLE LANDING GOLF CLUB 3989 EAGLE LANDING PKWY ORANGE PARK FL 32065-2641	<b>Ship To</b> EAGLE LANDING GOLF CLUB ATTN PRO SHOP 3989 EAGLE LANDING PKWY ORANGE PARK FL 32065-2641
---	--

<b>Remit To</b> Acushnet Company P.O. Box 830334 Philadelphia, PA 19182-0334	<b>Payment Terms</b> Net 75 Days <b>Payment Discount</b> 5% 60 Days <b>Delivery Method</b> FedEx Ground	<b>Due Date</b> 12/31/24  <b>Frt Acct No</b>
---	--	---

Item No	Shipped	U/M	Unit	Disc	Disc	Disc	Cstm	Net	Extended
---------	---------	-----	------	------	------	------	------	-----	----------

\*\* Custom Apparel\*\*

Logo Name:Eagles Landing  
 Logo ID:168169  
 Logo Placement:LEFT SLEEVE/LEFT CHEST

27940C-M	2	EA	\$34.50	4%			\$5.00	\$38.12	\$76.24
Sleeveless Shirt Wm Light Blue									
Total Shipped Qty.									2

<b>Net Order Total</b>	\$76.24
<b>Shipping and Handling Total</b>	\$2.73
<b>Total Invoice</b>	\$78.97

If paid by 12/16/24 deduct discount of \$ 3.81 ( 5.00 %) -- REMIT \$75.16

1320-7000

**Effective December 1, 2024 Acushnet Golf will no longer mail invoice and statement documents.**  
 Please contact us at 800-225-8500 to set-up electronic delivery today.  
 You can access your account online at Acushnetgolf.com.

Invoices not paid within thirty (30) days of due date shall incur a service charge at the rate of the lesser of one and one-half percent (1.5%) per month or the highest rate permitted by law on any outstanding overdue balance from original due date.  
**SEE REVERSE SIDE FOR CONDITIONS OF SALE.**



**ACUSHNET COMPANY**  
 P.O. BOX 965 FAIRHAVEN, MA 02719-0965  
 Tel: 800-225-8500 Fax: 508-979-3913



**INVOICE**  
 Currency: USD

Tax No: 04-2591836

<b>Invoice No</b> 919176237		<b>Invoice Date</b> 10/30/24	<b>Shipment Date</b> 10/30/24	<b>Order Date</b> 10/18/24
<b>Order No</b> 3024997705	<b>Whs</b> 05P	<b>Delivery No</b> 59519422	<b>Customer P.O.</b> 2024 MEMBER/GUEST	<b>Account No</b> US00027669 \ US00040574

**Sold To**  
 SOUTH VILLAGE COMMUNITY DEVELOP  
 DISTRICT DBA EAGLE LANDING GOLF CLUB  
 3989 EAGLE LANDING PKWY  
 ORANGE PARK FL 32065-2641

**Ship To**  
 MELISSA MALLOY  
 1263 AUTUMN PINES DR  
 ORANGE PARK FL 32065-2693

**Remit To**  
 Acushnet Company  
 P.O. Box 830334  
 Philadelphia, PA 19182-0334

**Payment Terms**  
 Net 60 Days  
**Payment Discount**  
 NA  
**Delivery Method**  
 FedEx Ground  
**Due Date**  
 12/29/24  
**Frnt Acct No**

Item No	Shipped	U/M	Unit	Disc	Disc	Cstm	Net	Extended
56913 M130	1	PR	\$114.00	10%			\$102.60	\$102.60
ProSLX MEN BLK/WHT/GRY				Tag For: M MALLOY				
Per Pair Shipping Fee								\$5.00
<b>Total Shipped Qty.</b>	<b>1</b>							

**Net Order Total** \$102.60  
**Shipping and Handling Total** \$5.00  
**Total Invoice** \$107.60

7480 - 100  
 EJC  
 [Signature]  
 1/21/25

**Effective December 1, 2024 Acushnet Golf will no longer mail invoice and statement documents.**  
 Please contact us at 800-225-8500 to set-up electronic delivery today.  
 You can access your account online at Acushnetgolf.com.

Invoices not paid within thirty (30) days of due date shall incur a service charge at the rate of the lesser of one and one-half percent (1.5%) per month or the highest rate permitted by law on any outstanding overdue balance from original due date.  
**SEE REVERSE SIDE FOR CONDITIONS OF SALE.**



**ACUSHNET COMPANY**  
 P.O. BOX 965 FAIRHAVEN, MA 02719-0965  
 Tel: 800-225-8500 Fax: 508-979-3913



**INVOICE**  
 Currency: USD

Tax No: 04-2591836

<b>Invoice No</b> 919182847		<b>Invoice Date</b> 10/31/24	<b>Shipment Date</b> 10/31/24	<b>Order Date</b> 10/18/24
<b>Order No</b> 3024997705	<b>Whs</b> 05P	<b>Delivery No</b> 59519367	<b>Customer P.O.</b> 2024 MEMBER/GUEST	<b>Account No</b> US00027669 \ US00040574

<b>Sold To</b> SOUTH VILLAGE COMMUNITY DEVELOP DISTRICT DBA EAGLE LANDING GOLF CLUB 3989 EAGLE LANDING PKWY ORANGE PARK FL 32065-2641	<b>Ship To</b> JOE FELIX 1011 GREEN PINE CIR ORANGE PARK FL 32065-2568
---	---

<b>Remit To</b> Acushnet Company P.O. Box 830334 Philadelphia, PA 19182-0334	<b>Payment Terms</b> Net 60 Days <b>Payment Discount</b> NA <b>Delivery Method</b> FedEx Ground	<b>Due Date</b> 12/30/24  <b>Frt Acct No</b>
---	--	---

Item No	Shipped	U/M	Unit	Disc	Disc	Disc	Cstm	Net	Extended
54331 W115	1	PR	\$120.00	10%				\$108.00	\$108.00
DJ Premiere MEN WHT/BLK/BLK			Tag For: J FELIX						
Per Pair Shipping Fee									\$5.00
<b>Total Shipped Qty.</b>		<b>1</b>							

<b>Net Order Total</b>	\$108.00
<b>Shipping and Handling Total</b>	\$5.00
<b>Total Invoice</b>	\$113.00

7480-100

**Effective December 1, 2024 Acushnet Golf will no longer mail invoice and statement documents.**  
 Please contact us at 800-225-8500 to set-up electronic delivery today.  
 You can access your account online at Acushnetgolf.com.

Invoices not paid within thirty (30) days of due date shall incur a service charge at the rate of the lesser of one and one-half percent (1.5%) per month or the highest rate permitted by law on any outstanding overdue balance from original due date.  
**SEE REVERSE SIDE FOR CONDITIONS OF SALE.**





**ACUSHNET COMPANY**  
 P.O. BOX 965 FAIRHAVEN, MA 02719-0965  
 Tel: 800-225-8500 Fax: 508-979-3913



**INVOICE**  
 Currency: USD

Tax No: 04-2591836

<b>Invoice No</b> 919182848		<b>Invoice Date</b> 10/31/24	<b>Shipment Date</b> 10/31/24	<b>Order Date</b> 10/18/24
<b>Order No</b> 3024997705	<b>Whs</b> 05P	<b>Delivery No</b> 59519399	<b>Customer P.O.</b> 2024 MEMBER/GUEST	
			<b>Account No</b> US00027669	US00040574

**Sold To**  
 SOUTH VILLAGE COMMUNITY DEVELOP  
 DISTRICT DBA EAGLE LANDING GOLF CLUB  
 3989 EAGLE LANDING PKWY  
 ORANGE PARK FL 32065-2641

**Ship To**  
 ANDREW KOKOSKA  
 564 WELLHOUSE DR  
 JACKSONVILLE FL 32220-1372

**Remit To**  
 Acushnet Company  
 P.O. Box 830334  
 Philadelphia, PA 19182-0334

**Payment Terms**  
 Net 60 Days  
**Payment Discount**  
 NA  
**Delivery Method**  
 FedEx Ground  
**Due Date**  
 12/30/24  
**Frt Acct No**

Item No	Shipped	U/M	Unit	Disc	Disc	Cstm	Net	Extended
55543 M115	1	PR	\$120.00	10%			\$108.00	\$108.00
Tour Alpha MEN WHT/WHT/SIL				Tag For: A KOKOSKA				
Per Pair Shipping Fee								\$5.00
<b>Total Shipped Qty.</b>	<b>1</b>							

<b>Net Order Total</b>	\$108.00
<b>Shipping and Handling Total</b>	\$5.00
<b>Total Invoice</b>	\$113.00

7480-100

**Effective December 1, 2024 Acushnet Golf will no longer mail invoice and statement documents.**  
 Please contact us at 800-225-8500 to set-up electronic delivery today.  
 You can access your account online at Acushnetgolf.com.

Invoices not paid within thirty (30) days of due date shall incur a service charge at the rate of the lesser of one and one-half percent (1.5%) per month or the highest rate permitted by law on any outstanding overdue balance from original due date.  
**SEE REVERSE SIDE FOR CONDITIONS OF SALE.**



**ACUSHNET COMPANY**  
 P.O. BOX 965 FAIRHAVEN, MA 02719-0965  
 Tel: 800-225-8500 Fax: 508-979-3913



**INVOICE**  
 Currency: USD

Tax No: 04-2591836

<b>Invoice No</b> 919182849		<b>Invoice Date</b> 10/31/24	<b>Shipment Date</b> 10/31/24	<b>Order Date</b> 10/18/24
<b>Order No</b> 3024997705	<b>Whs</b> 05P	<b>Delivery No</b> 59519416	<b>Customer P.O.</b> 2024 MEMBER/GUEST	<b>Account No</b> US00027669 \ US00040574

**Sold To**  
 SOUTH VILLAGE COMMUNITY DEVELOP  
 DISTRICT DBA EAGLE LANDING GOLF CLUB  
 3989 EAGLE LANDING PKWY  
 ORANGE PARK FL 32065-2641

**Ship To**  
 ABNER DAVIS  
 4328 EAGLE LANDING PKWY  
 ORANGE PARK FL 32065-2633

**Remit To**  
 Acushnet Company  
 P.O. Box 830334  
 Philadelphia, PA 19182-0334

**Payment Terms**  
 Net 60 Days  
**Payment Discount**  
 NA  
**Delivery Method**  
 FedEx Ground  
**Due Date**  
 12/30/24  
**Frt Acct No**

Item No	Description	Shipped	U/M	Unit	Disc	Disc	Disc	Cstm	Net	Extended
53992 M115	DJ Prem Men CWH/CWH/RED	1	PR	\$120.00	10%				\$108.00	\$108.00
	Per Pair Shipping Fee									\$5.00
	<b>Total Shipped Qty.</b>	<b>1</b>								

<b>Net Order Total</b>	\$108.00
<b>Shipping and Handling Total</b>	\$5.00
<b>Total Invoice</b>	\$113.00

7480-100

**Effective December 1, 2024 Acushnet Golf will no longer mail invoice and statement documents.**  
 Please contact us at 800-225-8500 to set-up electronic delivery today.  
 You can access your account online at Acushnetgolf.com.

Invoices not paid within thirty (30) days of due date shall incur a service charge at the rate of the lesser of one and one-half percent (1.5%) per month or the highest rate permitted by law on any outstanding overdue balance from original due date.  
**SEE REVERSE SIDE FOR CONDITIONS OF SALE.**



**ACUSHNET COMPANY**  
 P.O. BOX 965 FAIRHAVEN, MA 02719-0965  
 Tel: 800-225-8500 Fax: 508-979-3913



**INVOICE**  
 Currency: USD

Tax No: 04-2591836

<b>Invoice No</b> 919182850		<b>Invoice Date</b> 10/31/24	<b>Shipment Date</b> 10/31/24	<b>Order Date</b> 10/18/24
<b>Order No</b> 3024997705	<b>Whs</b> 05P	<b>Delivery No</b> 59519442	<b>Customer P.O.</b> 2024 MEMBER/GUEST	<b>Account No</b> US00027669 \ US00040574

**Sold To**  
 SOUTH VILLAGE COMMUNITY DEVELOP  
 DISTRICT DBA EAGLE LANDING GOLF CLUB  
 3989 EAGLE LANDING PKWY  
 ORANGE PARK FL 32065-2641

**Ship To**  
 BILL RUDAY  
 12540 MISSION HILLS CIR N  
 JACKSONVILLE FL 32225-4629

**Remit To**  
 Acushnet Company  
 P.O. Box 830334  
 Philadelphia, PA 19182-0334

**Payment Terms**  
 Net 60 Days  
**Payment Discount**  
 NA  
**Delivery Method**  
 FedEx Ground  
**Due Date**  
 12/30/24  
**Frnt Acct No**

Item No	Description	Shipped	U/M	Unit	Disc	Disc	Cstm	Net	Extended
54396 M120	Premiere Series MN WHT/WHT/NVY	1	PR	\$135.00	10%			\$121.50	\$121.50
	Per Pair Shipping Fee								\$5.00
	<b>Total Shipped Qty.</b>	<b>1</b>							

**Net Order Total** \$121.50  
**Shipping and Handling Total** \$5.00  
**Total Invoice** \$126.50

7480-100

**Effective December 1, 2024 Acushnet Golf will no longer mail invoice and statement documents.**  
 Please contact us at 800-225-8500 to set-up electronic delivery today.  
 You can access your account online at [Acushnetgolf.com](http://Acushnetgolf.com).

Invoices not paid within thirty (30) days of due date shall incur a service charge at the rate of the lesser of one and one-half percent (1.5%) per month or the highest rate permitted by law on any outstanding overdue balance from original due date.  
**SEE REVERSE SIDE FOR CONDITIONS OF SALE.**



**ACUSHNET COMPANY**  
 P.O. BOX 965 FAIRHAVEN, MA 02719-0965  
 Tel: 800-225-8500 Fax: 508-979-3913



**INVOICE**  
 Currency: USD

Tax No: 04-2591836

<b>Invoice No</b> 919182851		<b>Invoice Date</b> 10/31/24	<b>Shipment Date</b> 10/31/24	<b>Order Date</b> 10/18/24
<b>Order No</b> 3024997705	<b>Whs</b> 05P	<b>Delivery No</b> 59519459	<b>Customer P.O.</b> 2024 MEMBER/GUEST	<b>Account No</b> US00027669 \ US00040574

**Sold To**  
 SOUTH VILLAGE COMMUNITY DEVELOP  
 DISTRICT DBA EAGLE LANDING GOLF CLUB  
 3989 EAGLE LANDING PKWY  
 ORANGE PARK FL 32065-2641

**Ship To**  
 ALBERT MONTALBO  
 UNIT 222  
 10550 BAYMEADOWS RD  
 JACKSONVILLE FL 32256-4522

**Remit To**  
 Acushnet Company  
 P.O. Box 830334  
 Philadelphia, PA 19182-0334

**Payment Terms**  
 Net 60 Days  
**Payment Discount**  
 NA  
**Delivery Method**  
 FedEx Ground  
**Due Date**  
 12/30/24  
**Frnt Acct No**

Item No	Description	Shipped	U/M	Unit	Disc	Disc	Disc	Cstm	Net	Extended
54396 W100	Premiere Series MN WHT/WHT/NVY	1	PR	\$135.00	10%				\$121.50	\$121.50
	Per Pair Shipping Fee									\$5.00
	<b>Total Shipped Qty.</b>	<b>1</b>								

**Net Order Total** \$121.50  
**Shipping and Handling Total** \$5.00  
**Total Invoice** \$126.50

7480 - 100

**Effective December 1, 2024 Acushnet Golf will no longer mail invoice and statement documents.**  
 Please contact us at 800-225-8500 to set-up electronic delivery today.  
 You can access your account online at [Acushnetgolf.com](http://Acushnetgolf.com).

Invoices not paid within thirty (30) days of due date shall incur a service charge at the rate of the lesser of one and one-half percent (1.5%) per month or the highest rate permitted by law on any outstanding overdue balance from original due date.  
**SEE REVERSE SIDE FOR CONDITIONS OF SALE.**



**ACUSHNET COMPANY**  
 P.O. BOX 965 FAIRHAVEN, MA 02719-0965  
 Tel: 800-225-8500 Fax: 508-979-3913



**INVOICE**  
 Currency: USD

Tax No: 04-2591836

<b>Invoice No</b> 919182852		<b>Invoice Date</b> 10/31/24	<b>Shipment Date</b> 10/31/24	<b>Order Date</b> 10/18/24
<b>Order No</b> 3024997705	<b>Whs</b> 05P	<b>Delivery No</b> 59519473	<b>Customer P.O.</b> 2024 MEMBER/GUEST	<b>Account No</b> US00027669 \ US00040574

**Sold To**  
 SOUTH VILLAGE COMMUNITY DEVELOP  
 DISTRICT DBA EAGLE LANDING GOLF CLUB  
 3989 EAGLE LANDING PKWY  
 ORANGE PARK FL 32065-2641

**Ship To**  
 CRAIG SCOTT  
 10749 STANTON HILLS DR E  
 JACKSONVILLE FL 32222-1459

**Remit To**  
 Acushnet Company  
 P.O. Box 830334  
 Philadelphia, PA 19182-0334

**Payment Terms**  
 Net 60 Days  
**Payment Discount**  
 NA  
**Delivery Method**  
 FedEx Ground

**Due Date**  
 12/30/24

**Frnt Acct No**

Item No	Shipped	U/M	Unit	Disc	Disc	Disc	Cstm	Net	Extended
53992 M120	1	PR	\$120.00	10%				\$108.00	\$108.00
DJ Prem Men CWH/CWH/RED				Tag For: C SCOTT					
Per Pair Shipping Fee									\$5.00
<b>Total Shipped Qty.</b>	<b>1</b>								

**Net Order Total** \$108.00  
**Shipping and Handling Total** \$5.00  
**Total Invoice** \$113.00

7480 - 100

**Effective December 1, 2024 Acushnet Golf will no longer mail invoice and statement documents.**  
 Please contact us at 800-225-8500 to set-up electronic delivery today.  
 You can access your account online at Acushnetgolf.com.

Invoices not paid within thirty (30) days of due date shall incur a service charge at the rate of the lesser of one and one-half percent (1.5%) per month or the highest rate permitted by law on any outstanding overdue balance from original due date.  
**SEE REVERSE SIDE FOR CONDITIONS OF SALE.**



**ACUSHNET COMPANY**  
 P.O. BOX 965 FAIRHAVEN, MA 02719-0965  
 Tel: 800-225-8500 Fax: 508-979-3913



**INVOICE**  
 Currency: USD

Tax No: 04-2591836

<b>Invoice No</b> 919241408		<b>Invoice Date</b> 11/15/24	<b>Shipment Date</b> 11/15/24	<b>Order Date</b> 10/31/24
<b>Order No</b> 3025070145	<b>Whs</b> 04B	<b>Delivery No</b> 59705314	<b>Customer P.O.</b> NOV STOCK/ERNIE	<b>Account No</b> US00027669 \ US00040574

**Sold To**  
 SOUTH VILLAGE COMMUNITY DEVELOP  
 DISTRICT DBA EAGLE LANDING GOLF CLUB  
 3989 EAGLE LANDING PKWY  
 ORANGE PARK FL 32065-2641

**Ship To**  
 EAGLE LANDING GOLF CLUB  
 ATTN PRO SHOP  
 3989 EAGLE LANDING PKWY  
 ORANGE PARK FL 32065-2641

**Remit To**  
 Acushnet Company  
 P.O. Box 830334  
 Philadelphia, PA 19182-0334

**Payment Terms**  
 Net 60 Days  
**Payment Discount**  
 NA  
**Delivery Method**  
 FedEx Ground  
**Due Date**  
 01/14/25  
**Frnt Acct No**

Item No	Shipped	U/M	Unit	Disc	Disc	Cstm	Net	Extended
T2048S-2DHD Title Pro V1x Holiday 2-Dozen	6	P24	\$75.50	2%			\$73.99	\$443.94
<b>Total Shipped Qty.</b>	<b>6</b>							

**Net Order Total** \$443.94  
**Shipping and Handling Total** \$17.96  
**Total Invoice** \$461.90

1325-~~100~~<sup>000</sup>  
 E.J.  
 [Signature]  
 1/21/25

**Effective December 1, 2024 Acushnet Golf will no longer mail invoice and statement documents.**  
 Please contact us at 800-225-8500 to set-up electronic delivery today.  
 You can access your account online at Acushnetgolf.com.

Invoices not paid within thirty (30) days of due date shall incur a service charge at the rate of the lesser of one and one-half percent (1.5%) per month or the highest rate permitted by law on any outstanding overdue balance from original due date.  
**SEE REVERSE SIDE FOR CONDITIONS OF SALE.**



**ACUSHNET COMPANY**  
P.O. BOX 965 FAIRHAVEN, MA 02719-0965  
Tel: 800-225-8500 Fax: 508-879-3913



**INVOICE**  
Currency: USD

Tax No: 04-2591836

Invoice No 919287407		Invoice Date 11/25/24	Shipment Date 11/25/24	Order Date 01/23/24
Order No 3023518665	Whs 05A	Delivery No 54257708	Customer P.O. FJ OUTER 11/15	Account No US00027669 \ US00040574

**Sold To**  
SOUTH VILLAGE COMMUNITY DEVELOP  
DISTRICT DBA EAGLE LANDING GOLF CLUB  
3889 EAGLE LANDING PKWY  
ORANGE PARK FL 32065-2641

**Ship To**  
EAGLE LANDING GOLF CLUB  
ATTN PRO SHOP  
3989 EAGLE LANDING PKWY  
ORANGE PARK FL 32065-2641

**Remit To**  
Acushnet Company  
P.O. Box 830334  
Philadelphia, PA 19182-0334

**Payment Terms**  
Net 75 Days  
Payment Discount  
5% 60 Days  
Delivery Method  
FedEx Ground

**Due Date**  
02/08/25

**Frt Acct No**

Item No	Shipped	U/M	Unit	Disc	Disc	Cstm	Net	Extended
Description								
30548C-XXL Thermo Pullover Hoodie Sky	1	EA	\$82.50	4%		\$5.00	\$65.00	\$65.00
30554C-L Thermo Hthr Brushed Mid Sky	2	EA	\$57.50	4%		\$5.00	\$60.20	\$120.40
30554C-M Thermo Hthr Brushed Mid Sky	1	EA	\$57.50	4%		\$5.00	\$60.20	\$60.20
30554C-XL Thermo Hthr Brushed Mid Sky	2	EA	\$57.50	4%		\$5.00	\$60.20	\$120.40
30554C-XXL Thermo Hthr Brushed Mid Sky	1	EA	\$57.50	4%		\$5.00	\$60.20	\$60.20
<b>Total Shipped Qty.</b>	<b>30</b>							

**Net Order Total** \$1,863.60  
**Shipping and Handling Total** \$28.40  
**Total Invoice** \$1,890.00

If paid by 01/24/25 deduct discount of \$ 93.18 ( 5.00 %) – REMIT \$1,796.82

Effective December 1, 2024 Acushnet Golf will no longer mail invoice and statement documents.  
Please contact us at 800-225-8500 to set-up electronic delivery today.  
You can access your account online at Acushnetgolf.com.

Invoices not paid within thirty (30) days of due date shall incur a service charge at the rate of the lesser of one and one-half percent (1.5%) per month or the highest rate permitted by law on any outstanding overdue balance from original due date.  
**SEE REVERSE SIDE FOR CONDITIONS OF SALE.**





**ACUSHNET COMPANY**  
 P.O. BOX 965 FAIRHAVEN, MA 02719-0965  
 Tel: 800-225-8500 Fax: 508-879-3913

2275-000



*[Handwritten signature]*  
~~1320~~ 100

**INVOICE**  
 Currency: USD

Tax No: 04-2591836

Invoice No 819287407	Invoice Date 11/25/24	Shipment Date 11/25/24	Order Date 01/23/24
Order No 3023518655	Whs 05A	Delivery No 54257708	Customer P.O. FJ OUTER 11/15
			Account No US00027689
\ US00040574			

<b>Sold To</b> SOUTH VILLAGE COMMUNITY DEVELOP DISTRICT DBA EAGLE LANDING GOLF CLUB 3989 EAGLE LANDING PKWY ORANGE PARK FL 32065-2641	<b>Ship To</b> EAGLE LANDING GOLF CLUB ATTN PRO SHOP 3989 EAGLE LANDING PKWY ORANGE PARK FL 32065-2641
---	--

<b>Remit To</b> Acushnet Company P.O. Box 830334 Philadelphia, PA 19182-0334	<b>Payment Terms</b> Net 75 Days Payment Discount 5% 60 Days Delivery Method FedEx Ground	<b>Due Date</b> 02/08/25	<b>Frt Acct No</b>
---	--	-----------------------------	--------------------

Item No	Shipped	U/M	Unit	Disc	Disc	Cstm	Net	Extended
Description								

\*\* Custom Apparel\*\*

Logo Name: EAGLES LANDING  
 Logo ID: 168169  
 Logo Placement: LEFT SLEEVE

*[Handwritten signature]*  
 11/21/24

30438C-L	2	EA	\$57.50	4%		\$5.00	\$60.20	\$120.40
Tonal Pinwheel Midlayer Pitnm								
30438C-M	1	EA	\$57.50	4%		\$5.00	\$60.20	\$60.20
Tonal Pinwheel Midlayer Pitnm								
30438C-XL	2	EA	\$57.50	4%		\$5.00	\$60.20	\$120.40
Tonal Pinwheel Midlayer Pitnm								
30438C-XXL	1	EA	\$57.50	4%		\$5.00	\$60.20	\$60.20
Tonal Pinwheel Midlayer Pitnm								
30441C-L	2	EA	\$57.50	4%		\$5.00	\$60.20	\$120.40
Tonal Block Midlayer Lake Blue								
30441C-M	1	EA	\$57.50	4%		\$5.00	\$60.20	\$60.20
Tonal Block Midlayer Lake Blue								
30441C-XL	2	EA	\$57.50	4%		\$5.00	\$60.20	\$120.40
Tonal Block Midlayer Lake Blue								
30441C-XXL	1	EA	\$57.50	4%		\$5.00	\$60.20	\$60.20
Tonal Block Midlayer Lake Blue								
30545C-L	2	EA	\$62.50	4%		\$5.00	\$65.00	\$130.00
Thermo PulloverHoodie Nvy/Slt								
30545C-M	1	EA	\$62.50	4%		\$5.00	\$65.00	\$65.00
Thermo PulloverHoodie Nvy/Slt								
30545C-XL	2	EA	\$62.50	4%		\$5.00	\$65.00	\$130.00
Thermo PulloverHoodie Nvy/Slt								
30545C-XXL	1	EA	\$62.50	4%		\$5.00	\$65.00	\$65.00
Thermo PulloverHoodie Nvy/Slt								
30548C-L	2	EA	\$62.50	4%		\$5.00	\$65.00	\$130.00
Thermo Pullover Hoodie Sky								
30548C-M	1	EA	\$62.50	4%		\$5.00	\$65.00	\$65.00
Thermo Pullover Hoodie Sky								
30548C-XL	2	EA	\$62.50	4%		\$5.00	\$65.00	\$130.00
Thermo Pullover Hoodie Sky								

Invoices not paid within thirty (30) days of due date shall incur a service charge at the rate of the lesser of one and one-half percent (1.5%) per month or the highest rate permitted by law on any outstanding overdue balance from original due date.  
 SEE REVERSE SIDE FOR CONDITIONS OF SALE.



**ACUSHNET COMPANY**  
 P.O. BOX 965 FAIRHAVEN, MA 02719-0965  
 Tel: 800-225-8500 Fax: 508-979-3913

2275-000

~~100/1320~~  
*[Handwritten signature]*



**INVOICE**  
 Currency: USD

Tax No: 04-2591836

Invoice No 919356518		Invoice Date 12/06/24	Shipment Date 12/06/24	Order Date 11/26/24
Order No 3025194336	Whs 05P	Delivery No 80070044	Customer P.O. CARSON CRAVEN - PUD	Account No US00027889

1 US00040574

**Sold To**  
 SOUTH VILLAGE COMMUNITY DEVELOP  
 DISTRICT DBA EAGLE LANDING GOLF CLUB  
 3989 EAGLE LANDING PKWY  
 ORANGE PARK FL 32065-2641

**Ship To**  
 EAGLE LANDING GOLF CLUB  
 ATTN PRO SHOP  
 3989 EAGLE LANDING PKWY  
 ORANGE PARK FL 32065-2641

**Remit To**  
 Acushnet Company  
 P.O. Box 830334  
 Philadelphia, PA 19182-0334

**Payment Terms**  
 Net 60 Days  
 Payment Discount  
 NA  
 Delivery Method  
 FedEx Ground

**Due Date**  
 02/04/25

**Frt Acct No**

Item No	Description	Shipped	U/M	Unit	Disc	Disc	Cstm	Net	Extended
56958 W110	Tour Rival MEN WHT/WHT/BLK	1	PR	\$66.00		25%	Personal Use	\$49.50	\$49.50
	<b>Total Shipped Qty.</b>	1							

<b>Net Order Total</b>	\$49.50
<b>Shipping and Handling Total</b>	\$10.46
<b>Sales Tax</b>	\$4.50
<b>Total Invoice</b>	\$64.46

*[Handwritten signature]*  
 12/17/24

**Effective December 1, 2024 Acushnet Golf will no longer mail invoice and statement documents.**  
 Please contact us at 800-225-8500 to set-up electronic delivery today.  
 You can access your account online at Acushnetgolf.com.

Invoices not paid within thirty (30) days of due date shall incur a service charge at the rate of the lesser of one and one-half percent (1.5%) per month or the highest rate permitted by law on any outstanding overdue balance from original due date.  
**SEE REVERSE SIDE FOR CONDITIONS OF SALE.**



REMIT PAYMENT TO:  
 CINTAS CORP  
 P.O. BOX 630910  
 CINCINNATI, OH 45263-0910

VIEW & PAY YOUR BILLS ONLINE:  
 WWW.CINTAS.COM/MYACCOUNT

CUSTOMER SVC/BILLING 833-290-0514  
 CINTAS FAX # 904-741-6116  
 PAYMENT INQUIRY 904-741-4525

INVOICE

SHIP TO: EAGLE LANDING GOLF CLUB  
 3989 EAGLE LANDING PKWY  
 ORANGE PARK, FL 32065-2641

INVOICE # 4217772295  
 INVOICE DATE 01/14/2025  
 CUSTOMER REF # SOUTH VILLAGE  
 COMMUNITY DEVT DISTR

BILL TO: EAGLE LANDING GOLF CLUB  
 3989 EAGLE LANDING PKWY  
 ORANGE PARK, FL 32065-2641

SOLD TO # 22390656  
 PAYER # 22385762  
 PAYMENT TERMS NET 10 EOM  
 SORT # 02800003369  
 CINTAS ROUTE 53 / DAY 2 / STOP 010

EQPS/LOCKS	MATERIAL	DESCRIPTION	FREQ	EXCH	QTY	UNIT PRICE	LINE TOTAL	TAX
	X20023	SIG HRDND WHT LRG-	01	F	12	9.520	114.24	N
	X2700	TERRY TOWEL - WHITE-	01	F	320	0.202	64.64	N *
	X2700	TERRY TOWEL - WHITE-	L 01	F	29	0.601	17.43	N *
	X27026	SIG AIR SVC	01	F	21	3.867	81.21	N
	X27070	SIG SOAP RFL FOAM-	04	F	10	11.900	119.00	N
	X27097	SIG TRASHCAN DSP ALU-	01	F	24	1.190	28.56	N
	X2873	BIB APRON-BLACK-	01	F	60	0.444	26.64	N *
	X2873	BIB APRON-BLACK-	L 01	F	1	9.261	9.26	N *
	X6680	DISP URINAL MAT SVC	01	F	9	2.380	21.42	N
	X9110	JRT TOILET TISSUE REFILL-	01	F	12	4.760	57.12	N
	X9213	SANIS SCREEN SERVICE	01	F	9	2.380	21.42	N
		SUBTOTAL					560.94	
		SERVICE CHARGE					7.08	N
		SUBTOTAL					568.02	
		TAX					(0.00)	
		TOTAL USD					568.02	

1460-000 -250.00  
 1470-000 250.00

*Handwritten:* Subtotal 240 7465 LINEN - 117.97

*Handwritten:* 240 7465 LINEN - 117.97

*Handwritten:*  
 - OPS SUPPLY -  
 240-7440 - 130.05  
 200-7440 - 70.00  
 600-7440 - 150.00  
 400-7440 - 100.00

TOTAL ADJUST.

TAX ADJUST.

NET TOTAL

*Handwritten signature and date:* 1/14/25

chase Employee gifts or company swag through account.cintas.com and use code SH0PLAUNCH for 10% off your \*first  
 line order of \$150 or more. \*  
 promotion ends 1/31/2025.





**DE LAGE LANDEN FINANCIAL SERVICES, INC.**  
 PO BOX 825736  
 PHILADELPHIA, PA 19182-5736

**Remittance Section**

Invoice Number: 589073730  
 Due Date: 02/01/2025  
 Due This Period: \$262.83

Amount Enclosed: \$ \_\_\_\_\_

025650 000004329



SOUTH VILLAGE COMMUNITY DEVELOPMENT  
 ATTN AP  
 3989 EAGLE LANDING PKWY  
 ORANGE PARK FL 32065-2641



2

7340-500

Please make check payable to

DE LAGE LANDEN FINANCIAL SERVICES, INC.  
 PO BOX 825736  
 PHILADELPHIA, PA 19182-5736

2100005890737300000262831

Detach here. Please include the top payment coupon with your payment. Please allow 5-7 days for U.S. Postal Service delivery.



DE LAGE LANDEN FINANCIAL SERVICES,  
 INC.  
 PO BOX 825736  
 PHILADELPHIA, PA 19182-5736  
 www.leasedirect.com

Contract Number: 25489964  
 Invoice Number: 589073730  
 Account Number: 1211524  
 Site Number: 4256556  
 Invoice Date: 01/08/2025  
 Period of Performance: 01/01/2025 - 01/31/2025  
 Due This Period: \$262.83

*Tex exempt @ LEASE DIRECT.COM*

**Important Messages**

See Reverse For Important Information

**Invoice Details**

Description	Payment Amount	Tax	Total Amount	Applied Amount	Remaining Amount Due
INSURANCE	\$19.54	\$1.46	\$21.00	\$0.00	\$21.00
LATE FEE	\$12.52	\$0.00	\$12.52	\$0.00	\$12.52
PAYMENT	\$213.31	\$16.00	\$229.31	\$0.00	\$229.31
<b>Billed this Invoice</b>	<b>\$245.37</b>	<b>\$17.46</b>	<b>\$262.83</b>	<b>\$0.00</b>	<b>\$262.83</b>
Balance Due Previous Invoices					\$297.14
<b>Total Amount Due</b>					<b>\$559.97</b>

(Please see the following pages for details.)

*Call [unclear]*

*# 245,37  
 PAY THIS AMOUNT  
 DO NOT PAY TAX!  
 PRIOR INVOICES  
 RECEIVED*

*[Handwritten signatures and scribbles]*

**Asset Details**

Contract Number	Purchase Order	Make / Model	Asset Number	Serial Number	Install Date	Cost Center	Department	Payment Amount	Tax	Total Amount
25489964		KONMIN / BHC368	25489964_1	A7PLU01700432 7	02/20/2018			\$213.31	\$16.00	\$229.31
Asset Location: 3989 EAGLE LANDING PKWY ORANGE PARK CLAY FL 32065-2641 United States								<b>Asset Amount Total:</b>		<b>\$229.31</b>



2

**Account Summary**

Invoice Number	Due Date	Amount Invoiced	Balance Due
588912768	01/01/2025	\$250.31	\$250.31
588944257	01/06/2025	\$46.83	\$46.83
<b>BALANCE DUE FOR PRIOR BILLED INVOICES</b>			<b>\$297.14</b>

**Late Fee and Finance Charge Details**

Past Due Invoice Number	Past Due Invoice Description	Past Due Invoice Due Date	Past Due Invoice Balance Subject to Late Charges	Past Due Invoice Payment Date	Late Fee	Finance Charge
588912768		01/01/2025	\$250.31		\$12.52	



Account Number: A00001702  
 Account Balance: \$2,212.50  
 Account Currency: USD

Eagle Landing Golf Club  
 Jim Hahn  
 3989 Eagle Landing Pkwy  
 Orange Park, Florida 32065-2641  
 United States

**Invoice Summary**

Invoice Number: INV00100068  
 Invoice Date: 01/06/2025  
 PO Number:  
 Invoice Total: \$737.50  
 Due Date: 02/05/2025  
 Invoice Balance: \$737.50

**CHARGES**

Product	Charge Description	Service Period	Subtotal	Tax	TOTAL
Golf365 Premier Tee Sheet (Cloud based)	Golf365 Premier Tee Sheet (Cloud based) with Booking Engine and EZTP Users	01/01/25 - 01/31/25	\$737.50	\$0.00	\$737.50

**Customer Payment Portal:** <https://paymentsportal.golfnow.com>

OR

**Mail Remit To:**  
 GolfNow  
 PO Box 742569  
 Atlanta, GA 30374-2569

**Wire/ACH Payment To:**  
 Bank of America  
 Wire ABA Routing No.: 026009593  
 ACH Routing No.: 111000012  
 Bank Acct No: 4427779172  
 International SWIFT Code: BOFAUS3N  
 Account Name: Eagle Landing Golf Club  
 Account No: A00001702

Discounts	\$0.00
Invoice Total	\$737.50
Payments / Credits	
Invoice Balance	\$737.50
Account Balance	\$2,212.50

**IMPORTANT:** Please remit payment to **GolfNow** and reference Inv Number: **INV00100068**  
 If you have questions, please notify your sales representative and/or email [AR-GolfNow@nbcuni.com](mailto:AR-GolfNow@nbcuni.com).

**USAGE SUMMARY** (if applicable)

Location	Description	Period	Quantity	Rate	Total
----------	-------------	--------	----------	------	-------

!W-7310  
 8  
 [Signature]  
 1/7/25



**Invoice**  
 Paul Murray Oil, Inc.  
 2900 Phoenix Ave

Jacksonville, FL 32208 USA  
 Phone: (804)353-1411

Remit To: 2900 Phoenix Ave Jacksonville, FL 32206

Account Number: 18040030  
 Invoice Number: RO161395  
 Invoice Date: 01/08/2025 11:12:49 AM  
 Delivery Date: 01/08/2025 11:12:49 AM

400-7740  
 1/13/24  
 JS

Amount Due: ~~\$424.92~~  
 Due Date: 02/07/2025

Eagle Landing CC  
 3989 Eagle Landing Pkwy  
 Orange Park, FL 32065

Shipping Address:  
 Eagle Landing CC  
 3989 Eagle Landing Pkwy  
 Orange Park, FL 32065

HM	DOT- Name, Class, ID, Group	Product Description	Delivered Quantity	Unit Price	Extended Price
	Carrier: PMO	Vehicle: none	Salesperson: none		
	Order Number: RO161395	Purchase Order Number: none	BOL Number: RO161395		
	231/Bulk	Dyed Ultra Low Sulfur Diesel	0.0000	\$3.00240	\$0.00
				NET 30 Terms:	\$0.00
CRITICAL DESCRIPTION: DYED ULTRA LOW SULFUR FUEL; NON-TAXABLE USE ONLY. PENALTY FOR TAXABLE USE. MAX SULFUR OF 15PPM, MAX CLOUD OF 15, MIN CETANE OF 40 & MAY CONTAIN UP TO 5% BIODIESEL					
Item Note: Full					
	Carrier: PMO	Vehicle: none	Salesperson: none		
	Order Number: RO161395	Purchase Order Number: none	BOL Number: RO161395		
	065/Bulk	Regular Gasoline/Bulk	96.0000	\$2.44280	\$234.51
				Tax:	\$56.03
				Total This Item:	\$290.54
				NET 30 Terms:	\$0.00
	Carrier: PMO	Vehicle: none	Salesperson: none		
	Order Number: RO161395	Purchase Order Number: none	BOL Number: RO161395		
	PMO Service Fee	PMO Service Fee	1.0000	\$125.00000	\$125.00
				Tax:	\$9.38
				Total This Item:	\$134.38
				NET 30 Terms:	\$0.00

417.42

Pay \$359.51  
 TAXES NOT removed  
 from invoice  
 sent tot 2/3 7:45 AM  
 DO NOT pay  
 tot \$359.51

Invoice Taxes	Certificate Number	Amount Due	Exempt
Federal Excise Tax - LUST		\$0.10	No
Federal Gas Excise Tax		\$17.57	No
Fed Envir Fee - 10% Ethanol		\$0.19	No
Fed Envir Fee - Diesel		\$0.00	No
Florida Fuel Tax		\$20.76	No
Florida Pollution Fee		\$1.99	No
Florida Local Option Tax		\$5.76	No
Florida S.C.E.T.S.		\$9.31	No
Florida Sales Tax		\$7.50	No
Clay Co SUR Tax		\$1.88	No
Fed Superfund Recovery - Diesel		\$0.00	No
Fed Superfund Recovery - 10% Ethanol		\$0.55	No

DEDUCTED FROM TOTAL

No terms discount available for this invoice.

Products Total:	\$359.51
Shipping / Freight Total:	\$0.00
Header Freight Surcharge:	\$0.00
Tax Total:	\$66.41
Invoice Total:	\$425.92
Discount Total:	\$0.00
Net Invoice Total:	\$425.92
Total Due:	\$425.92





4613 Philips Hwy 208B Jacksonville, FL 32207  
(904)661-7590

### Important Messages



Protect yourself from scams. Sharp Energy will never use phone or email to ask for personal information, threaten disconnection or demand immediate payment.

Sharp Energy.com/securebill



### Remittance Address



### Stay Connected

Be sure to follow us on social media for updates and emergency messages.



### Invoice Information

Customer Name: SOUTH VILLAGE, CDD  
Account Number: 2036053  
Current Balance: \$744.80  
Invoice Date: 01/15/25  
Due Date: Upon Receipt  
Amount Due: \$3,117.94

Finance charge of 1.5% per month assessed on balances over 30 days  
Sharpgas, Inc. Fed# 51-0255314

### Summary of Transactions

DATE	REF #	DESCRIPTION	AMOUNT
		PREVIOUS BALANCE	\$2,373.14
01/13/25	15217	BULK PROPANE JACKSONVILLE 244.3GALS@\$2.9657	\$724.52
01/13/25	15217	COUNTY UTILITY TAX /3989 EAGLE LANDING PARKWAY Y/ORANGE PARK FL 32065	\$20.28

### Summary of Amount Due

Previous Balance	\$2,373.14
Current Transactions	\$744.80
<b>Amount Due:</b>	<b>\$3,117.94</b>

**WARNING:** (1) Over time, propane could experience odor fade. For your added safety, we recommend you consider purchasing and installing a propane detector. These can be found at most retail hardware stores. (2) Please be aware that there are unaffiliated bill pay websites that may represent themselves as Sharp Energy. To securely pay your bill online, please visit our website at SharpEnergy.com.

Page 1 of 2

Please detach and return this portion with your payment. Please do not staple, clip or attach check to the remittance payment coupon.

Please bring entire invoice when paying in person.

4613 Philips Hwy 208B  
Jacksonville, FL 32207  
Return Service Requested

210-7740  
6  
APR  
1/21/25

### Remittance Section

Account Number: 2036053  
Invoice Date: 01/15/25  
Due Date: Upon Receipt  
Amount Due: \$3,117.94  
Amount Paid: \$ \_\_\_\_\_

Please do not staple, clip or attach check to the remittance payment coupon. Make check payable to: Sharp Energy, Inc. Write your account number on your check. Save a stamp! Pay online at www.SharpEnergy.com Thank you!

**\*\*INVOICE\*\***

SOUTH VILLAGE, CDD  
3989 EAGLE LANDING PKWY  
ATTN: JAMES HAHN  
ORANGE PARK, FL 32065

SHARP ENERGY JACKSONVILLE  
PO BOX 829981  
PHILADELPHIA, PA 19182-9981



000102036053001521700031179400000000000031179457



300 Colonial Center Pkwy, Suite 550  
Roswell, GA 30078-4883

**BILL TO:**

SOUTH VILLAGE COMMUNITY DEVELOPMENT  
EAGLE LANDING GOLF CLUB  
3989 EAGLE LANDING PKWY  
ORANGE PARK FL 32065-2641

7750-400  
12/6/24  
[Signature]

**SALES INVOICE**

<b>CUSTOMER #</b>	<b>INVOICE #</b>
1345761	147846894-0013
<b>INVOICE DATE</b>	<b>DUE DATE</b>
12/04/2024	02/02/2025

**LOCAL BRANCH:**  
ORANGE PARK FL # 128  
105 INDUSTRIAL LOOP N  
ORANGE PARK, FL 32073-2849  
904-269-4159

**SHIP TO:**

EAGLE LANDING GOLF CLUB  
890 OAKLEAF PLANTATION PKWY  
ORANGE PARK, FL 32065

<b>ORDER #</b>	<b>PO #</b>	<b>SHIP VIA</b>	<b>CUSTOMER CONTACT</b>	<b>SALES ASSOCIATE</b>
147846894-001	JON ROE	DELIVERY	JON ROE	JASON WILKERSON
<b>TERMS</b>			<b>PROJECT NAME</b>	
NET 60 DAYS				

LN	ITEM #	DESCRIPTION	QTY ORDER	QTY SHIP	QTY CANC	QTY OPEN	NET PRICE	EXT PRICE
1	B1019081	SPRAY TIP SS TEEJET 11004-SS	24	12	0	0	10.2120 / EA	122.54

[Handwritten signature and date 12/6/24]

The Go-To App for Landscape Pros: SiteOne's mobile app makes your job easier with features designed to keep your business moving, such as real time product inventory, 24/7 ordering, time-saving tools and more. Learn more and download at SiteOne.com/Mobile.

Do you have EDI platform and would like to get the invoices electronically imported into your system? If so, please contact us at EDI@SiteOne.com for the next steps. Thank you for your business.

**PLEASE REMIT PAYMENT TO:**  
SITEONE LANDSCAPE SUPPLY, LLC  
24110 NETWORK PLACE  
CHICAGO, IL 60673-1241

SUBTOTAL:	\$122.54
SALES TAX:	\$0.00
FREIGHT:	\$0.00
TOTAL:	\$122.54
TOTAL PAYMENT:	\$0.00
<b>AMOUNT DUE:</b>	<b>\$122.54</b>

**CUSTOMER SIGNATURE:** \_\_\_\_\_

SiteOne Landscape Supply warrants that all products conform to the description on the label. Because conditions of use, which are of critical importance are beyond our control, seller makes no warranty, expressed or implied, concerning the use of these products. No employee of the company is authorized to make any warranty or representation, expressed or implied, concerning our products. Always follow directions and carefully observe all precautions on the label or manufacturer's instructions. Products used contrary to directions may cause serious plant or personal injury. Buyer assumes all risk of use of handling whether in accordance with direction or not and accepts the products sold to them by this company on these conditions.

Note: Returns subject to 25% restock charge.

CUSTOMER'S ORIGINAL INVOICE CONFIDENTIAL PROPERTY OF SYSCO

DELV. DATE	CUSTOMER	INVOICE NUMBER	PACK
1/04/25			
TRUCK STOP	784966	583034924	6 3
621/002			
ROUTE	PURCHASE ORDER		
6637	TERMS -PAST DUE BALANCES ARE SUBJECT TO SERVICE CHARGE		
	Net 30		
	MANIFEST# 1276541 NORMAL DELIVERY		
	MA: TVADC SCARLETT BAYLESS		



EAGLE LANDING GOLF CLUB  
3989 EAGLE LANDING PKWY  
ORANGE PARK FL 32065-2641



SYSCO JACKSONVILLE, INC.  
1501 LEWIS INDUSTRIAL DRIVE  
JACKSONVILLE, FL 32254  
1-800-797-2627 (1-800 SYSCO CS

904-637-0648

EAGLE LANDING GOLF CLUB  
3989 EAGLE LANDING PKWY  
ORANGE PARK FL 32065 -2641

DRIVER:

QTY	PACK	SIZE	ITEM DESCRIPTION	ITEM CODE	UNIT PRICE	UNIT TAX AMOUNT	EXTENDED PRICE	TAX	INVOICE ADJUSTMENTS	
									CODE	QTY
GROUP TOTAL****							57.45			
MISC CHARGES			ALLOWANCE FOR DROP SIZE				11.36-	*		
			CHGS FOR FUEL SURCHARGE				6.00			
ORDER SUMMARY			: 2750561 2755052							

*[Handwritten signature]*

000  
240-1340 = 896.31  
240-7450 = 292.16  
Total = 1188.47

CASES	SPLIT	NO. PCS	CUBE	GROSS WT.	OPEN: 7:00 AM	CLOSE: 5:00 PM	REMIT TO	SUB TOTAL		
28	9	37	32.7	600			SYSCO JACKSONVILLE 1501 LEWIS INDUSTRIAL DR. JACKSONVILLE, FL 32254	1188.47		
DRIVER'S SIGN							NO. PCS DELVD.	CUST. SIGNED INVOICE EVIDENCES OF ALL ITEMS SIGN <b>X</b>	NO. PCS REC.	TAX TOTAL
										INVOICE TOTAL
										1188.47

IMPORTANT PACK PROVISION: THE PERISHABLE AGRICULTURAL COMMODITIES LISTED ON THIS INVOICE ARE SUBJECT TO THE STATUTORY TRUST ESTABLISHED BY SECTION 5 (C) OF THE PERISHABLE AGRICULTURAL COMMODITIES ACT 1930 (U.S.C. 495E(C)). THE SELLER OF THIS COMMODITY WIELDS A TRUST CLAIM OVER THESE COMMODITIES, ALL INVENTORIES OF FOOD OR OTHER PRODUCTS DERIVED FROM THESE COMMODITIES, AND ANY RECEIVABLES OR PROCEEDS FROM THE SALE OF THESE COMMODITIES UNTIL FULL PAYMENT IS RECEIVED. FURTHER, YOU AGREE WITH RESPECT TO ANY DISPUTE ARISING OUT OF YOUR RECEIPT OF THESE PRODUCTS/SERVICES: YOU ARE GIVING UP YOUR RIGHT TO SERVE IN ANY REPRESENTATIVE CAPACITY, OR TO PARTICIPATE AS A MEMBER OF A CLASS OF CLAIMANTS, IN ANY LAWSUIT INVOLVING ANY SUCH DISPUTE.

PAYABLE ON OR BEFORE 2/03/25 LAST PAGE

EQUAL OPPORTUNITY AND AFFIRMATIVE ACTION CLAUSES OF 41 CFR 60-1.4, 60-250.6 AND 60-714.4 ARE INCORPORATED HEREIN BY REFERENCE.



EAGLE LANDING GOLF CLUB  
3989 EAGLE LANDING PKWY  
ORANGE PARK FL 32065-2641



SYSCO JACKSONVILLE, INC.  
1501 LEWIS INDUSTRIAL DRIVE  
JACKSONVILLE, FL 32254  
1-800-797-2627 (1-800 SYSCO CS

904-637-0648

EAGLE LANDING GOLF CLUB  
3989 EAGLE LANDING PKWY  
ORANGE PARK FL 32065 -2641

CUSTOMER'S ORIGINAL INVOICE CONFIDENTIAL PROPERTY OF SYSCO

DELV. DATE	CUSTOMER	INVOICE NUMBER	PAGE
1/04/25	784966	583034924	6 1
TRACK STOP	621/002		
ROUTE	6637	PURCHASE ORDER	
	TERMS -PAST DUE BALANCES ARE SUBJECT TO SERVICE CHARGE		
	Net 30		
	MANIFEST# 1276541 NORMAL DELIVERY		
	MA: TVADC SCARLETT BAYLESS		

DRIVER:

QTY	PACK	SIZE	ITEM DESCRIPTION	ITEM CODE	UNIT PRICE	UNIT EXT. AMOUNT	EXTENDED PRICE	TAX	INVOICE ADJUSTMENTS
FOOD SAFETY REMINDER: NOTHING IS MORE IMPORTANT TO SYSCO THAN DELIVERING SAFE PRODUCTS. PLEASE VERIFY EACH ORDER UPON RECEIPT BECAUSE COOLER ITEMS CANNOT BE RETURNED LATER. SALTWATER FISH LIC WD-4511 FRESHWATER FISH LIC FWD-303 SHELLFISH CERT NUMBER 182 SS									
***DAIRY***									
C	1	CS	81.5 LB BR LIMP CHEESE PROV NONSMK SLI .75	170754	3546386	42.16	42.16		
C	1	CS	1214 OZ SYS REL TOPPING WHPD ARSL	1004235	9814583	35.82	35.82		
							77.98		
***MEATS***									
F	1	CS	325 OZ CAB BEEF STEAK PHILLY CAB BR 10000001650		9789785	81.85	81.85		
							81.85		
***SEAFOOD***									
F	1	CS	42.5 LB PORTCLS SHRIMP WHT P&D TLOF 16/2 261512071PB		5106388	65.85	65.85		
							65.85		
***POULTRY***									
F	1	CS	25 LB SYS CLS CHICKEN WING BNLS HMSTYL PCK 8666164		8666164	45.49	45.49		
							45.49		
***FROZEN***									
F	1	CS	210 IN BLSMO CAKE LYR 3 CANNOLI 14 SLICES		7194803	91.76	91.76		
F	1	CS	14.75 LB BRKLYN DESSERT TIRAMISU PRECUT CAKE TC14		2973622	26.81	26.81		
F	1	CS	82 LB TANTLER ONION RING BRD GOURM 5/8IN 30410		0916387	57.07	57.07		
F	2	CS	722.4 OZ BAV BAK PRETZEL BAVARIAN STK 3295		6849145	38.89	77.78		
							253.42		
***CANNED & DRY***									
C	1	S	ONLY1 GAL KENS DRESSING BALSAMIC VINEGARETTE KE0955		7872328	16.98	16.98		
D	1	CS	2420 OZ GATRADE DRINK FROST RIPTIDE R 10052000324881		8399529	29.84	29.84		

CASES	SPLIT	TOT. PCS	CUBE	GROSS WT.	OPEN: 7:00 AM	CLOSE: 5:00 PM	REMIT TO		
11	1	12	7.8	172			SYSCO JACKSONVILLE 1501 LEWIS INDUSTRIAL JACKSONVILLE, FL 32254	571.41	
DRIVER'S SIGN	NO. PCS DELVD.	CUST. SIGNED INVOICE EVIDENCE OF ALL ITEMS SIGN	NO. PCS REC.						TAX TOTAL
									INVOICE TOTAL

IMPORTANT FACT PROVISION: THE PERISHABLE AGRICULTURAL COMMODITIES LISTED ON THIS INVOICE ARE SUBJECT TO THE STATUTORY TRUST AUTHORIZED BY SECTION 5 (C) OF THE PERISHABLE AGRICULTURAL COMMODITIES ACT 1930 (U.S.C. 495(C)). THE SELLER OF THIS COMMODITY RETAINS A TRUST CLAIM OVER THESE COMMODITIES, ALL INVENTORIES OF FOOD OR OTHER PRODUCTS DERIVED FROM THESE COMMODITIES AND ANY RECEIVABLES OR PROCEEDS FROM THE SALE OF THESE COMMODITIES UNTIL FULL PAYMENT IS RECEIVED. FURTHER, YOU AGREE WITH RESPECT TO ANY DISPUTE ARISING OUT OF YOUR RECEIPT OF THESE PRODUCTS/SERVICES: YOU ARE GIVING UP YOUR RIGHT TO SERVE IN ANY REPRESENTATIVE CAPACITY, OR TO PARTICIPATE AS A MEMBER OF A CLASS OF CLAIMANTS, IN ANY LAWSUIT INVOLVING ANY SUCH DISPUTE.

PAYABLE ON OR BEFORE  
CONT. ON PAGE 2

EQUAL OPPORTUNITY AND AFFIRMATIVE ACTION CLAUSES OF 41 CFR 60-1.4, 60-250.4 AND 60-714.4 ARE INCORPORATED HEREIN BY REFERENCE



EAGLE LANDING GOLF CLUB  
3989 EAGLE LANDING PKWY  
ORANGE PARK FL 32065-2641



SYSCO JACKSONVILLE, INC.  
1501 LEWIS INDUSTRIAL DRIVE  
JACKSONVILLE, FL 32254  
1-800-797-2627 (1-800 SYSCO CS

904-637-0648

EAGLE LANDING GOLF CLUB  
3989 EAGLE LANDING PKWY  
ORANGE PARK FL 32065 -2641

CUSTOMER'S ORIGINAL INVOICE CONFIDENTIAL PROPERTY OF SYSCO

DELV. DATE	CUSTOMER	INVOICE NUMBER	PAGE
1/04/25	784966	583034924	6 2
TRUCK STOP	621/002		
ROUTE	PURCHASE ORDER		
6637	TERMS -PAST DUE BALANCES ARE SUBJECT TO SERVICE CHARGE		
Net 30			
MANIFEST# 1276541 NORMAL DELIVERY			
MA: TVADC SCARLETT BAYLESS			

DRIVER:

QTY	PACK	SIZE	ITEM DESCRIPTION	ITEM CODE	UNIT PRICE	UNIT TAX ADJUST	EXTENDED PRICE	TOT	P	INVOICE ADJUSTMENTS
D	1	CS	2420 OZ	GATRADE DRINK LEMON LIME G ZE 10052000042129	9901694	29.84	29.84			
D	2S	ONLY23	OZ	IMP/MCC SEASONING BLACKENED REDFIS 901293725	4029761	11.03	22.06			
D	1	CS	104 LB	SYS CLS SUGAR GRANULATED XFINE CANE 412006	2926727	41.79	41.79			
D	2	CS	4016.9OZ	NIAGARA WATER BOTTLED SPRING	9901031	13.73	27.46			
D	1	CS	612 CT	TAC MEX WRAP TORTILLA GRCL HERB 12 195210	8031852	23.16	23.16			
GROUP TOTAL****							191.13			
***PAPER & DISP***										
D	1	CS	11000CT	SYS CLS BAG PLAS TSHRT 11.5X6.5X21 11-11665	7065852	36.69	36.69			
D	1	CS	1509X9X3	SYS CLS CONTAINER FOAM HNG 1C D YTD199S10000	7551334	21.16	21.16			
D	2	CS	2025 CT	DART CUP FOAM TALL 20 OZ 20J16	4088886	27.56	55.12			
D	1S	ONLY500CT		SYS CLS FOIL SHEET 9X10.75IN SILVER W69372	6938500	11.19	11.19			
D	3	CS	10060 GAL	SYS REL LINER REPRO 38X58 1.5 ML X7658AKSX01	1763846	41.77	125.31			
D	1	CS	16250CT	SYS CLS TOWEL MULTIFOLD 9.4X9.2 WHT 4458693	4458693	42.69	42.69			
GROUP TOTAL****							292.16			
***PRODUCE***										
C	1	CS	1165 CT	RELFRSH LEMON CHOICE FRESH	2252054	46.35	46.35			
C	2	CS	148 CT	PACKER LIME FRESH	1079425	20.76	41.52			
C	1S	ONLY10	LB	IMPFRSH ONION YELLOW JUMBO FRESH SACK	7201992	9.07	9.07			
C	2S	ONLY5	LB	IMPFRSH ORANGE BAGGED FRESH 10889356163020	7289526	9.23	18.46			
C	2S	ONLY16	OZ	DRISCOL STRAWBERRY FRESH DRISCOLL	7582505	6.55	13.10			
GROUP TOTAL****							128.50			
***DISPENSER BEVERAGE***										
D	1	CS	12.5GAL	COCACOL SYRUP PIBB XTRA 14450298	9181512	57.45	57.45			

CASES	SPLIT	TOT.PCS	CUYB	GROSS WT.	OPEN: 7:00 AM	CLOSE: 5:00 PM
17	8	25	24.9	428		

REMIT TO	SYSCO JACKSONVILLE	1501 LEWIS INDUSTRIAL DR	JACKSONVILLE, FL 32254
TOTAL	1193.83		
TAX	TOTAL	INVOICE	TOTAL

DRIVER'S SIGN	NO. PCS DELVD.	CUST. SIGNED INVOICE EVIDENCES OF ALL ITEMS SIGN	NO. PCS REC.
		X	

IMPORTANT NOTICE: THE PERISHABLE AGRICULTURAL COMMODITIES LISTED ON THIS INVOICE ARE SUBJECT TO THE STATUTORY TRUST AUTHORIZED BY SECTION 5 (C) OF THE PERISHABLE AGRICULTURAL COMMODITIES ACT 1930 (U.S.C. 495E(C)). THE SELLER OF THIS COMMODITY RETAINS A TRUST CLAIM OVER THESE COMMODITIES. ALL INVENTORIES OF FOOD OR OTHER PRODUCTS DERIVED FROM THESE COMMODITIES AND ANY RECEIVABLES OR PROCEEDS FROM THE SALE OF THESE COMMODITIES UNTIL FULL PAYMENT IS RECEIVED. FURTHER, YOU AGREE WITH RESPECT TO ANY DISPUTE ARISING OUT OF YOUR RECEIPT OF THESE PRODUCTS/SERVICES: YOU ARE GIVING UP YOUR RIGHT TO SERVE IN ANY REPRESENTATIVE CAPACITY, OR TO PARTICIPATE AS A MEMBER OF A CLASS OF CLAIMANTS, IN ANY LITIGATION INVOLVING ANY SUCH DISPUTE.

PAYABLE ON OR BEFORE  
CONT. ON PAGE 3

EQUAL OPPORTUNITY AND AFFIRMATIVE ACTION CLAUSES OF 41 CFR 60-1.4, 60-250.4 AND 60-744.4 ARE INCORPORATED HEREIN BY REFERENCE





EAGLE LANDING GOLF CLUB  
3989 EAGLE LANDING PKWY  
ORANGE PARK FL 32065-2641



SYSCO JACKSONVILLE, INC.  
1501 LEWIS INDUSTRIAL DRIVE  
JACKSONVILLE, FL 32254  
1-800-797-2627 (1-800 SYSCO CS)

904-637-0648

EAGLE LANDING GOLF CLUB  
3989 EAGLE LANDING PKWY  
ORANGE PARK FL 32065 -2641

CUSTOMER'S ORIGINAL INVOICE CONFIDENTIAL PROPERTY OF SYSCO

DELV. DATE	CUSTOMER	INVOICE NUMBER	PAGE
1/08/25	784966	583038796	4 3
TRUCK STOP	PURCHASE ORDER		
347/014	TERMS - PAST DUE BALANCES ARE SUBJECT TO SERVICE CHARGE		
ROUTE	Net 30		
3612	MANIFEST# 1276928 NORMAL DELIVERY		
	MA: TVADC SCARLETT BAYLESS		

DRIVER: TEMPLETON

QTY	PACK	SIZE	ITEM DESCRIPTION	ITEM CODE	UNIT PRICE	UNIT TAX AMOUNT	EXTENDED PRICE	INVOICE ADJUSTMENTS
***DISPENSER BEVERAGE***								
1	CS	15 GAL	COCACOL SYRUP COKE CLASSIC 5X1 BIB 04250010	4090593	110.15		110.15	
1	CS	15GAL	MINMAID SYRUP LEMONADE BIB 16760010	8856122	110.15		110.15	
1	CS	15 GAL	SPRITE SYRUP SPRITE 5X1 BIB 09560010	4090395	110.15		110.15	
1	BX	324 OZ	LUZIANN TEA BREW FILTER PACK 47900-30384	6738173	55.53		55.53	
MISC CHARGES				GROUP TOTAL****			385.98	
				ALLOWANCE FOR DROP SIZE			14.54-	
				CHGS FOR FUEL SURCHARGE			6.00	
ORDER SUMMARY				: 2759846				

000  
240-1340=1500.84  
240-7450=262.06  
Total=1762.90

CASES	SPLIT	TOT. PCS	CUBE	GROSS WT.	OPEN: 7:00 AM	CLOSE: 5:00 PM	REMIT TO	SUB TOTAL
4		4	3.4	171			SYSCO JACKSONVILLE 1501 LEWIS INDUSTRIAL DR. JACKSONVILLE, FL 32254	1775.07
31	10	41	39.8	945				TAX TOTAL
DRIVER'S SIGN								INVOICE TOTAL
NO. PCS DELVD.								1775.07
CUST. SIGNED INVOICE EVIDENCES OF ALL ITEMS SIGN X								
NO. PCS REC.								

IMPORTANT PICA PROVISION: THE PERISHABLE AGRICULTURAL COMMODITIES LISTED ON THIS INVOICE ARE SUBJECT TO THE STATUTORY TRUST AUTHORIZED BY SECTION 5 (C) OF THE PERISHABLE AGRICULTURAL COMMODITIES ACT 1930 (U.S.C. 498 (C)). THE SELLER OF THIS COMMODITY RETAINS A TRUST CLAIM OVER THESE COMMODITIES. ALL INVENTORIES OF FOOD OR OTHER PRODUCTS DERIVED FROM THESE COMMODITIES, AND ANY RECEIVABLES OR PROCEEDS FROM THE SALE OF THESE COMMODITIES UNTIL FULL PAYMENT IS RECEIVED. FURTHER, YOU AGREE WITH RESPECT TO ANY DISPUTE ARISING OUT OF YOUR RECEIPT OF THESE PRODUCTS/SERVICES: YOU ARE GIVING UP YOUR RIGHT TO SERVE IN ANY REPRESENTATIVE CAPACITY, OR TO PARTICIPATE AS A MEMBER OF A CLASS OF CLAIMANTS, IN ANY LAWSUIT INVOLVING ANY SUCH DISPUTE.

PAYABLE ON OR BEFORE 2/07/25

LAST PAGE - 12/17 - 1790

EQUAL OPPORTUNITY AND AFFIRMATIVE ACTION CLAUSES OF 41 CFR 60-1.4, 60-250.4 AND 60-714.4 ARE INCORPORATED HEREIN BY REFERENCE





EAGLE LANDING GOLF CLUB  
3989 EAGLE LANDING PKWY  
ORANGE PARK FL 32065-2641



SYSCO JACKSONVILLE, INC.  
1501 LEWIS INDUSTRIAL DRIVE  
JACKSONVILLE, FL 32254  
1-800-797-2627 (1-800 SYSCO CS)

904-637-0648

EAGLE LANDING GOLF CLUB  
3989 EAGLE LANDING PKWY  
ORANGE PARK FL 32065 -2641

CUSTOMER'S ORIGINAL INVOICE CONFIDENTIAL PROPERTY OF SYSCO

DELV. DATE	CUSTOMER	INVOICE NUMBER	PAGE
1/08/25	784966	583038796	4 1
TRUCK STOP	347/014		
ROUTE	3612	PURCHASE ORDER	
		TERMS - PAST DUE BALANCES ARE SUBJECT TO SERVICE CHARGE	
		Net 30	
		MANIFEST# 1276928 NORMAL DELIVERY	
		MA: TVADC SCARLETT BAYLESS	

DRIVER: TEMPLETON

QTY	PACK	SIZE	ITEM DESCRIPTION	ITEM CODE	UNIT PRICE	UNIT TAX AMOUNT	EXTENDED PRICE	T	P	I	INVOICE ADJUSTMENTS
											CODE QTY
FOOD SAFETY REMINDER: NOTHING IS MORE IMPORTANT TO SYSCO THAN DELIVERING SAFE PRODUCTS. PLEASE VERIFY EACH ORDER UPON RECEIPT BECAUSE COOLER ITEMS CANNOT BE RETURNED LATER. SALTWATER FISH LIC WD-4511 FRESHWATER FISH LIC FWD-803 SHELLFISH CERT NUMBER 182 SS											
***DAIRY***											
C	1S	ONLY5 LB	AREZIMP CHEESE MOZZARELLA LMPS SHRD 100721	9008335	15.95		15.95				
C	1 CS	3849 ML	INT DEL CREAMER REAL DAIRY HALF & HAL 136469	0358608	17.98		17.98				
C	1 CS	41 GAL	WHLFCLS MILK WHL GALLON GROUP TOTAL****	4676306	23.93		23.93				57.86
***MEATS***											
F	1 CS	325 OZ	CAB BEEF STEAK PHILLY CAB BR 10000001650	9789785	81.85		81.85				81.85
***POULTRY***											
C	5 CS	410 LB	SYS CLS CHICKEN CVP WING 1&2JT JMB RND 14688	6344790	103.98		519.90				519.90
***FROZEN***											
F	1 CS	1212 CT	BKRSCLS BUN HOT DOG WHITE 6 HINGD 54607120A	7223080	32.24		32.24				
F	1 CS	82LB	TANTLZR ONION RING BRD GOURM 5/8IN 30410	0916387	57.07		57.07				
F	1 CS	62.5 LB	MCCAIN POTATO FRY SWEET 5/16 MCF03731	3700499	31.08		31.08				
F	1 CS	34 LB	SYS CLS SOUP FAGIOLA PASTA CONC 000035568	2582120	39.79		39.79				160.18
***CANNED & DRY***											
C	1S	ONLY36 CT	MARS CANDY BAR 3 MUSKETEER 42208	1760531	37.83		37.83				
D	1S	ONLY.5GAL	SYS IMP CHERRY MARA STEM LG PLAS 10111158	5083944	22.76		22.76				
D	1 CS	2420 OZ	GATRADE DRINK FRUIT PUNCH G2 10052000204053	6508978	29.84		29.84				

CASES	SPLIT	TOT. PCS	CUBE	GROSS WT.	OPEN: 7:00 AM	CLOSE: 5:00 PM
13	3	16	13.3	386		

REMIT TO		
SYSCO JACKSONVILLE		
1501 LEWIS INDUSTRIAL DR		
JACKSONVILLE, FL 32254		
GRAND TOTAL		910.22
TAX TOTAL		
INVOICE TOTAL		

DRIVER'S SIGN	NO. PCS DELVD.	CUST. SIGNED INVOICE EVIDENCE OF ALL ITEMS SIGN	NO. PCS REC.
		X	

IMPORTANT FACT PROVISION: THE PERISHABLE AGRICULTURAL COMMODITIES LISTED ON THIS INVOICE ARE SUBJECT TO THE STATUTORY TRUST AUTHORITY BY SECTION 5 (C) OF THE PERISHABLE AGRICULTURAL COMMODITIES ACT 1930 (U.S.C. 485 (C)). THE SELLER OF THIS COMMODITY RETAINS A TRUST CLAIM OVER THESE COMMODITIES, ALL INVENTORIES OF FOOD OR OTHER PRODUCTS DERIVED FROM THESE COMMODITIES, AND ANY RECEIVABLES OR PROCEEDS FROM THE SALE OF THESE COMMODITIES UNTIL FULL PAYMENT IS RECEIVED. FURTHER, YOU AGREE WITH RESPECT TO ANY DISPUTE ARISING OUT OF YOUR RECEIPT OF THESE PRODUCTS/SERVICES: YOU ARE GIVING UP YOUR RIGHT TO SERVE IN ANY REPRESENTATIVE CAPACITY, OR TO PARTICIPATE AS A MEMBER OF A CLASS OF CLAIMANTS, IN ANY LITIGATION INVOLVING ANY SUCH DISPUTE.

PAYABLE ON OR BEFORE

CONT. ON PAGE 2

EQUAL OPPORTUNITY AND AFFIRMATIVE ACTION CLAUSES OF 41 CFR 60-1.4, 60-250.4 AND 60-714.4 ARE INCORPORATED HEREIN BY REFERENCE



EAGLE LANDING GOLF CLUB  
3989 EAGLE LANDING PKWY  
ORANGE PARK FL 32065-2641



At the heart of food and service  
SYSCO JACKSONVILLE, INC.  
1501 LEWIS INDUSTRIAL DRIVE  
JACKSONVILLE, FL 32254  
1-800-797-2627 (1-800 SYSCO CS)

904-637-0648

EAGLE LANDING GOLF CLUB  
3989 EAGLE LANDING PKWY  
ORANGE PARK FL 32065 -2641

CUSTOMER'S ORIGINAL INVOICE CONFIDENTIAL PROPERTY OF SYSCO

DELIV. DATE	CUSTOMER	INVOICE NUMBER	PAGE
1/08/25	784966	583038796	4 2
TRUCK STOP	PURCHASE ORDER		
347/014	3612		
TERMS - PAST DUE BALANCES ARE SUBJECT TO SERVICE CHARGE			
Net 30			
MANIFEST# 1276928 NORMAL DELIVERY			
MA: TVADC SCARLETT BAYLESS			

DRIVER: TEMPLETON

QTY	PACK	SIZE	ITEM DESCRIPTION	ITEM CODE	UNIT PRICE	UNIT TAX AMOUNT	EXTENDED PRICE	INVOICE ADJUSTMENTS
1	CS	2420 OZ	GATRADE DRINK LEMON LIME G ZE 10052000042129	9901694	29.84		29.84	
1	CS	1232 OZ	OCNSPRY JUICE CRNBRY BTL BAR MIXER 25900	5099122	24.47		24.47	
1	CS	1232 OZ	OCNSPRY JUICE PNAPL BTL BAR MIXER 25924	4042263	26.49		26.49	
1S	ONLY1 GAL	CASACLS	PEPPER JALAPENO SLICES 12730720211	8426330	12.17		12.17	<i>Damage</i>
3	CS	4016.9OZ	NIAGARA WATER BOTTLED SPRING	9901031	13.73		41.19	
GROUP TOTAL****							224.59	
***PAPER & DISP***								
1	CS	1509X9X3	SYS CLS CONTAINER FOAM HNG 1C D YTD199S10000	7551334	21.16		21.16	
1	CS	2025 CT	DART CUP FOAM TALL 20 OZ 20J16	4088886	27.56		27.56	
1	CS	250CT	SYS CLS KIT CUTLERY MED KFS/S&P YMKFSKWNPSY	0621999	27.91		27.91	
1	CS	10060 GAL	SYS REL LINER REPRO 38X58 1.5 ML X7658AKSX01	1763846	41.77		41.77	
2S	ONLY1000CT	HANGARD	PICK BAMBOO FRILL 4 IN 305214009	2102335	4.03		8.06	
1	CS	60400SHT	ANGLSFT TISSUE TOILET ANGLSFT 2PLY WHT 16560	8009401	92.91		92.91	
1	CS	16250CT	SYS CLS TOWEL MULTIFOLD 9.4X9.2 WHT 4458693	4458693	42.69		42.69	
GROUP TOTAL****							262.06	
***PRODUCE***								
2S	ONLY6 CT		SYFFNAT LETTUCE ICEBERG TRIMMED FRESH	1675610	9.94		19.88	
1	CS	14 OZ	IMPFRSH MINT FRESH HERB	2037109	6.81		6.81	
1S	ONLY10 LB		IMPFRSH ONION YELLOW JUMBO FRESH SACK	7201992	9.07		9.07	
1S	ONLY5 LB		IMPFRSH ORANGE BAGGED FRESH 10889356163020	7289526	9.23		9.23	
1	CS	28 LB	SYS IMP SALAD FRUIT CHPOG LT SYR 74865.64947	3856507	46.20		46.20	
GROUP TOTAL****							91.19	

CASES	SPLIT	NO. PCS	CUBE	GROSS WT.	OPEN: 7:00 AM	CLOSE: 5:00 PM
14	7	21	23.1	388		

REMIT TO	
SYSCO JACKSONVILLE	
1501 LEWIS INDUSTRIAL DR.	
JACKSONVILLE, FL 32254	GRAND TOTAL 1397.63

DRIVER'S SIGN	NO. PCS DELVD.	CUST. SIGNED INVOICE EVIDENCE OF ALL ITEMS SIGN	NO. PCS REC.
		X	

IMPORTANT FACA PROVISION: THE PERISHABLE AGRICULTURAL COMMODITIES LISTED ON THIS INVOICE ARE SUBJECT TO THE STATUTORY TRUST AUTHORIZED BY SECTION 5 (C) OF THE PERISHABLE AGRICULTURAL COMMODITIES ACT 1930 (U.S.C. 498(C)). THE SELLER OF THIS COMMODITY RETAINS A TRUST CLAIM OVER THESE COMMODITIES, ALL INVENTORIES OF FOOD OR OTHER PRODUCTS DERIVED FROM THESE COMMODITIES AND ANY RECEIVABLES OR PROCEEDS FROM THE SALE OF THESE COMMODITIES UNTIL FULL PAYMENT IS RECEIVED. FURTHER, YOU AGREE WITH RESPECT TO ANY DISPUTE ARISING OUT OF YOUR RECEIPT OF THESE PRODUCTS/SERVICES: YOU ARE GIVING UP YOUR RIGHT TO SERVE IN ANY REPRESENTATIVE CAPACITY, OR TO PARTICIPATE AS A MEMBER OF A CLASS OF CLAIMANTS, IN ANY LITIGATION INVOLVING ANY SUCH DISPUTE.

TAX TOTAL	
INVOICE TOTAL	
PAYABLE ON OR BEFORE	CONT. ON PAGE 3

EQUAL OPPORTUNITY AND AFFIRMATIVE ACTION CLAUSES OF 41 CFR 60-1.4, 60-250.4 AND 60-714.4 ARE INCORPORATED HEREIN BY REFERENCE



# Invoice

TableTop Linen Rental  
 898 Bellevue Ave.  
 support@tabletoplinen.com  
 Daytona Beach, FL 32114 (386)254-3158

EAGLE LANDING GOLF CLUB  
 3989 Eagle Landing Parkway  
 Orange Park, FL 32065 (904)860-7177

Date	Invoice	Day	Garment Mark	Freq.	Seq	Term	Account	Route
01/15/2025	0135363	Wed		7	30	CHG	1193-00000	7

Line	Item	Empl	Name / Description	Sizes	Qty.	OFFICE					ROUTE		Total
						Min.	Adj. Qty.	Adj. Amt.	Unit Pr.	Ext. Price	Adj. Qty.	Adj. Amt.	
1	FBNPW		NAPKIN WHITE			200	0	\$0.00	\$0.1320	\$26.40	0	\$0.00	\$26.40
2	FBNPW		NAPKIN WHITE			SRC	0	\$0.00	\$2.0000	\$4.00	0	\$0.00	\$4.00
3	DGBAGST		BAG STAND				0	\$0.00	\$0.1000	\$0.20	0	\$0.00	\$0.20
4	FB8585W		TC 85X85 WHITE			90	0	\$0.00	\$1.7600	\$158.40	0	\$0.00	\$158.40
5	FBMESBAG		MESH BAG			10	0	\$0.00	\$0.1000	\$1.00	0	\$0.00	\$1.00
6	DGCARTHAM		CART HAMPER				0	\$0.00	\$5.0000	\$10.00	0	\$0.00	\$10.00
7	TPP		TOTAL PROTECTION PLAN					\$0.00		\$9.80		\$0.00	\$9.80
			Delivery Charge					\$0.00		\$15.70		\$0.00	\$15.70

Total Due	Cur. Bus.	Cur. Bal.	30	60	90	120
\$612.86	\$419.18	\$193.68	\$0.00	\$0.00	\$0.00	\$0.00

Office Adj.:	\$0.00	Subtotal:	\$225.50	Rte. Adj.:	\$0.00
Tax Adj.:	\$0.00	Sales Tax:	\$0.00	Tax Adj.:	\$0.00
Net Adj.:	\$0.00	Prebill:	\$225.50	Net Adj.:	\$0.00

Total Adj.: \$0.00  
 Tax Adj.: \$0.00

Net Charge: **\$225.50**

Received By: \_\_\_\_\_ N 01/15/2025 12:42:05PM

*Ren #  
 240-7465  
 Linen  
 225.50  
 [Signature]  
 1/21/25*



# Invoice

460-7770  
1/18/25  
*[Signature]*

Reference Nbr.: 007533  
Date: 06-Jan-2025  
Due Date: 05-Feb-2025  
Customer ID: C0000559  
Master Inv Total: 986.88

Trigon Turf Sciences  
New Address  
Department # 5612  
P.O. Box 25008  
Bradenton, FL, 34206-5008  
Phone: 757-220-4466

**TOTAL Invoice: 986.88**

**BILL TO:**  
Eagle Landing Golf Club  
890 Oakleaf Plantation Pkwy  
Orange Park FL 32065  
United States of America

**SHIP TO:**  
Eagle Landing Golf Club  
890 Oakleaf Plantation Pkwy  
Orange Park FL 32065  
United States of America  
Attn: Jon Roe

CUSTOMER REF. NBR.		TERMS	CONTACT			
NO.	ITEM	Net 30	QTY.	UOM	UNIT PRICE	EXTENDED PRICE
1	10111: Quadcal 38-SP		6.00	PAIL15	130.00	780.00
2	Freight ShipVla		1.00		148.38	148.38

*[Large handwritten signature]*  
1/14/25

NOTE:

Tax Total: 58.50

<b>TOTAL Invoice:</b>	<b>986.88</b>
<b>Balance Remaining :</b>	<b>986.88</b>

ACCOUNT NO. 91221150 INVOICE NO. 2337623 INVOICE DATE 01/14/25 CUSTOMER NO. 11221140 PURCHASE ORDER NUMBER

SALES LOC 3055 SALES REP 0832 DATE ORDERED 01/12/25

Route: 2314 / 4

ORDER NUMBER 40701

Bill To: 50 VILLAGE COMM DEV DISTR  
3989 EAGLE LANDING PKWY  
ORANGE PARK FL 32065  
Att: CHRIS COLLETTI

Ship To: TRN EAGLE LANDING GLF CLB  
3989 EAGLE LANDING PKWY  
ORANGE PARK FL 32065  
904 291 5600  
DEPT # 00

Remit To: US Foods, Inc  
P O BOX 142421  
ATLANTA GA 30384-8421  
338 763 1304

Ship From: 5425 S WILLIAMSON BLVD PORT ORANGE FL Ship Date: 01/14/25 Page 03 of 04  
Special Instr: DRIVER MUST LEAVE FINAL RECEIPT FOR INV CHANGE

Qty Ordered	Qty Shipped	Sales Unit	Product Number	Description	Pack Size	Label	C	Month	Pricing Unit	Unit Price	Extended Price
-------------	-------------	------------	----------------	-------------	-----------	-------	---	-------	--------------	------------	----------------

TOTAL NET WGT: 1035.97  
TOTAL GROSS WGT: 1133.33

\*\*\* INVOICE SUMMARY \*\*\*  
PIECES ORDERED: 60 PIECES SHIPPED: 60 ITEMS SHIPPED: 45

PRODUCT TOTAL 4 2638.94

\* Federal Occupation Safety and Health Standards, Section 1910.1200 on Hazard Communication requires manufacturers and distributors to provide Material Safety Data Sheets on non-food products defined to be hazardous. Products such as cleaning products and pesticides are included in the scope of the Standard. In compliance with the law, MSDS are available to US Foods, Inc. customers and can be obtained by contacting the Procurement Manager in our district office or by advising your sales representative.  
\* You may contact HAZMAT HOTLINE at phone # (800) 424 - 8802.

TAXES AMOUNT \$ 00  
G.S. SALES TAX \$ 00

This amount is an estimate at time of shipping prior to adjustments made at delivery \$ 2638.94

\* You agree with respect to any dispute arising out of your purchase from US Foods: (i) you are giving up your right to serve in any representative capacity, or to participate as a member of a class, in any lawsuit; (ii) you also agree, at US Foods sole option, to submit to binding, individual arbitration of all claims; (iii) such arbitration shall be governed by the Federal Arbitration Act, 9 U.S.C. s.1 and conducted in accordance with the Commercial Rules of the American Arbitration Association; and (iv) each party shall pay half the costs of arbitration, and separately pay its own attorneys' fees and costs. For more information about the fuel surcharge, go to: <https://www.usfoods.com/terms/fuelsurcharge/StandardGridEIAAreaLowerAtlantic.htm>  
\* If you have an agreement with US Foods that expressly addresses the calculation of the fuel surcharge, please refer to that agreement.

000  
240-1340 = 2511.98  
240-7450 = 126.96  
Total = 2638.94

ACCOUNT INVOICE INVOICE CUSTOMER PURCHASE ORDER  
 NO. NO. DATE NO. NUMBER  
 91221150 2337623 01/14/25 11221140

SALES SALES DATE  
 LOC. REF. ORDERED  
 3055 0832 01/12/25

Route 2314 / 4

ORDER NUMBER 40701

Bill To: 50 VILLAGE COMM DEV DISTR  
 3989 EAGLE LANDING PKWY  
 ORANGE PARK FL  
 32065  
 Att: CHRIS COLLETTI

Ship To: TRN EAGLE LANDING GLF CLR  
 3989 EAGLE LANDING PKWY  
 ORANGE PARK FL  
 32065  
 904 291 5600  
 DEPT # 00

Remit To: US Foods, Inc  
 P.O. BOX 198421  
 ATLANTA GA  
 30384-8421  
 386 763 1304

Ship From: 5425 S. WILLIAMSON BLVD PORT ORANGE FL Ship Date: 01/14/25 Page 01 of 04  
 Terms: NET 21 DAYS Special Instr: DRIVER MUST LEAVE FINAL RECEIPT FOR INV CHANGE

Qty	Qty	Sales	Product	Description	Pack	Size	Label	C	Weight	Pricing	Unit	Extended
Ordered	Shipped	Unit	Number					B		Unit	Price	Price
				DRY								
2	CS	1328699	SHORTENING, FRYG SOYBN LID CLR35 LB	HARVEST WL	CS	30	0100				54.00	54.00
1	CS	1389113	DRINK, SODA GNDR ALE CANDA DRY24/10 OZ	CANADA DRY	CS	18	3800				16.66	16.66
1	CS	1859297	DRINK, SODA DR PPR CAN	24/12 OZ	CS	14	0300				14.01	14.01
1	CS	3554565	DRINK, SODA BOLA COKE CLSC CAN24/12 OZ	COKE	CS	16	2500				15.67	15.67
1	CS	3554649	DRINK, SODA DIET COKE ZERO	24/12 OZ	CS	18	2900				10.22	10.22
1	EA	4353462	SEASONING, TACO NO MSG SHLF	21 OZ	EA	7	7300				7.73	7.73
1	CS	5204151	SAUCE, CHS NACHO SHLF STABL	6/#10 CN	CS	29	1400				29.14	29.14
1	EA	5395767	SEASONING, LKN PPR SHLF STABL	28 OZ	EA	15	4300				15.43	15.43
2	CS	5651351	GR OVE, VINYL XL PF CLR AMBQY	10/100 EA	CS	21	6700				47.31	47.31
1	CS	5885134	CROUTON, CUBE HERB TFF HMSTY	8/2.5 LB	CS	50	2900				50.29	50.29
1	CS	6002378	KETCHUP, TMTD FCY 33% SS FOIL	1000/9 BR	CS	27	3000				27.30	27.30
1	CS	6204366	DRINK, DRNG PLST BTL WIDE	24/20 OZ	CS	25	1700				25.17	25.17
1	CS	6649289	SWEETENER, ADAGE NCTR SYRUP ?	LT	CS	39	1500				39.15	39.15
1	CS	7802523	HAPKIN, DNNR WHT 17X17 1 PLY	20/250 EA	CS	55	7400				55.74	55.74
1	CS	8914897	STRAW, JMB 7.75" BLK WRPD CLR	10/500 EA	CS	29	6800				29.68	29.68
			REFRIGERATED									
1	CS	1213404	DRESSING, BLU CHS PLST JAR REF4/1 GA	KEN'S	CS	73	9800				73.98	73.98
1	CS	1919740	COLESLAW, SHRD SHORT SWT DIXIE2/4.5 LB	MOLLYS KEY	CS	19	4900				19.49	19.49
			READY TO EAT - Please Refer to Return Policy									
1	EA	2348936	CARROT, STICK 3 3/4" FRESH	5 LB	EA	2	9400				2.94	2.94
			READY TO EAT - Please Refer to Return Policy									
3	CS	2721173	CHICKEN, WING 182UT JMB RAW	4/10 LB	CS	94	1200				94.12	94.12
3	CS	2725711	CHICKEN, BRST SNGL 6 Z BNLS	4/5 LB	CS	66	0800				66.08	66.08
1	CS	4207247	CORNEO BEEF, SLDG CKD REF	66 6/2 LB	CS	109	3100				109.31	109.31
			READY TO EAT - Please Refer to Return Policy									
1	CS	4284520	PEPPER, BELL RED CHD FRESH REF5 LB	PACKER	CS	14	0100				14.01	14.01
1	CS	5326418	LETTUCE, RMN FRESH REF	24 EA	CS	31	7000				31.70	31.70
3	CS	5327275	BEEF, PTY GRND 80/20 2:1 RND	20/8 OZ	CS	42	0000				42.00	42.00
1	EA	6712376	CANDY, SNCKR BAR SS IW REF Z	1.86 OZ	EA	53	4500				53.45	53.45
1	CS	7060429	SDUR CREAM, CLTD ALL NTRL TUS	4/5 LB	CS	30	9900				30.99	30.99
1	CS	7330004	GARLIC, CHPD IN OIL TFF TUB	6/32 OZ	CS	41	7300				41.73	41.73
2	EA	7331614	CELERY, STICK 4" FRESH REF	4/5 LB	EA	10	8300				10.83	10.83
			READY TO EAT - Please Refer to Return Policy									
1	CS	9124520	DRESSING, RANCH HMSTY PLST JAR4/1 GA	KEN'S	CS	46	0800				46.08	46.08
			READY TO EAT - Please Refer to Return Policy									
1	CS	9635729	SAUCE, REMLO PLST JAR REF	2/1 GA	CS	41	6500				41.65	41.65



ACCOUNT INVOICE INVOICE CUSTOMER PURCHASE ORDER  
 NO. NO. DATE NO. NUMBER  
 91221150 2337623 01/14/25 11221140

SALES SALES DATE  
 LOC. REP. ORDERED  
 3055 0832 01/12/25

Route: 2314 / 4

ORDER NUMBER: 40701

Bill To: 50 VILLAGE COMM DEV DISTR  
 3989 EAGLE LANDING PKWY  
 ORANGE PARK FL  
 32065  
 Att: CHRIS COLLETTI

Ship To: TRN EAGLE LANDING GLF CLB  
 3989 EAGLE LANDING PKWY  
 ORANGE PARK FL  
 32065  
 904 291 5500  
 DEPT # 00

From: US Foods, Inc  
 P O BOX 198421  
 ATLANTA GA  
 30184-8421  
 888 763 1304

Ship From: 5425 S. WILLIAMSON BLVD PORT ORANGE FL

Ship Date: 01/14/25

Page 02 of 04

Terms: NET 21 DAYS  
 Driver MUST LEAVE FINAL RECEIPT FOR IN/CHARGE

Qty Ordered	Qty Shipped	Sales Unit	Product Number	Description	Pack Size	Label	Weight	Pricing Unit	Unit Price	Extended Price
-------------	-------------	------------	----------------	-------------	-----------	-------	--------	--------------	------------	----------------

READY TO EAT - Please Refer to Return Policy

				FROZEN						
1	1	CS	0488239	ROLL, HDGI WHT 8" SLCD BKD FZNB/6/3.7 OZ		COSTANZO'S		CS	31.0200	31.02
1	1	CS	1054265	BUN, HOT DOG WHT 6" SLCD CKD 8/12/1.7 OZ		HILLTOP HR		CS	25.4000	25.40
1	1	CS	1475608	BREAD, FLAT SX13" OVAL BKD FZNB/3.61 OZ		STONEFIRE		CS	26.1600	26.16
1	1	CS	2122328	BEEF, STX TRD TP CC 1184R 60ZA24/6 OZA		STOCK YRDS	9.19	LB	11.4200	104.95
				CS: 0001 9.19 LBS						
4	4	CS	2883130	POTATO, FF SC 3/8" EXTRA CRSPY 6/5 LB		MONARCH		CS	50.1700	200.68
1	1	CS	3200145	SALMON, ATLNTC 6 Z FTW PRO 3D 10 LB		HARBOR BHK		CS	100.1400	100.14
2	2	CS	3330099	HOT DOG, AB 6:1 6" RLR GRIL 10 LB		PATUXENT		CS	30.8600	61.72
1	1	CS	4326880	MAHI MAHI, 6 Z PC BLSL RAW FZM10 LB		HARBOR BHK		CS	72.9500	72.95
1	1	CS	4358495	BACON, PORK 18-22C SLC LAID 2015 LB		PATUXENT		CS	52.6100	52.61
1	1	CS	5366760	BREAD, WHT 12.5" 21 SLCD 9/16" 6/28.32 OZ		ROTELLA		CS	23.0900	23.09
1	1	CS	5915319	APPETIZER, CHS MOZZ BRD 6/2 LB		LAMB WESTN		CS	64.9800	64.98
2	2	CS	6553758	ROLL, KGR WHT 4.5" SLCD BKD 6/8/3.5 OZ		ROTELLA		CS	31.6600	63.32
1	1	CS	7232562	MACARONI & CHEESE, CHEDR PRCKD 36/7 OZ		KRAFT		CS	34.9100	34.91
2	2	CS	7637713	CHICKEN, TNLH BTRD FRITR REEK 2/5 LB		PATUXENT		CS	34.7600	69.52
1	1	CS	7790513	PORK, RIB BABY BACK 19-25 Z 22.05 LB		AGROSUPER		CS	63.0400	63.04

STORAGE LOCATION RECAP(N)

TOTAL DRY	PIECES ORDERED:	17	PIECES SHIPPED:	17	ITEMS SHIPPED:	15	51.17
TOTAL REFRIGERATED	PIECES ORDERED:	22	PIECES SHIPPED:	22	ITEMS SHIPPED:	15	121.62
TOTAL FROZEN	PIECES ORDERED:	21	PIECES SHIPPED:	21	ITEMS SHIPPED:	15	103.75

ACCOUNT NO. 91221150 INVOICE NO. 2337624 INVOICE DATE 01/14/25 CUSTOMER NO. 11221140 PURCHASE ORDER NUMBER

SALES LDC. 3055 SALES REP. 0832 DATE ORDERED 01/12/25

Route: 2314 / 4

ORDER NUMBER. 40705

Bill To: 50 VILLAGE COMM DEV DISTR  
3989 EAGLE LANDING PKWY  
ORANGE PARK FL  
32065  
Att: CHRIS COLLETTI

Ship To: TRN EAGLE LANDING GLF CLB  
3989 EAGLE LANDING PKWY  
ORANGE PARK FL  
32065  
904 291 5600  
DEPT # 00

Bill To: US Foods, Inc  
P.O. BOX 198421  
ATLANTA GA  
30381-8421  
335 763 1304

Ship From: 5425 S WILLIAMSON BLVD PORT ORANGE FL Ship Date: 01/14/25 Page 01 of 03  
Special Instr: DRIVER MUST LEAVE FINAL RECEIPT FOR INV CHANGE

Qty Ordered	Qty Shipped	Sales Unit	Product Number	Description	Pack Size	Label	Weight	Pricing Unit	Unit Price	Extended Price
-------------	-------------	------------	----------------	-------------	-----------	-------	--------	--------------	------------	----------------

1	05	3331998		REFRIGERATED BROCCOLI, FLORET MINI ICELS REF4/3 LB READY TO EAT - Please Refer to Return Policy		CROSS VALY		CS	31.0100	31.01
---	----	---------	--	--	--	------------	--	----	---------	-------

STORAGE LOCATION RECAP(N)

TOTAL REFRIGERATED      PIECES ORDERED: 1      PIECES SHIPPED: 1      ITEMS SHIPPED: 1      31.01

TOTAL NET WGT: 12.00      \*\*\* INVOICE SUMMARY \*\*\*  
TOTAL GROSS WGT: 12.00      PIECES ORDERED: 1      PIECES SHIPPED: 1      ITEMS SHIPPED: 1

\*\*\*\*\*  
\* Federal Occupation Safety and Health Standards, Section 1910.1200 on Hazard  
\* Communication requires manufacturers and distributors to provide Material  
\* Safety Data Sheets on non-food products defined to be hazardous. Products  
\* such as cleaning products and pesticides are included in the scope of the  
\* Standard. In compliance with the law, MSDS are available to US Foods, Inc.  
\* customers and can be obtained by contacting the Procurement Manager in our  
\* district office or by advising your sales representative.  
\* You may contact HAZMAT HOTLINE at phone # (800) 424 - 8802.  
\*\*\*\*\*

PRODUCT TOTAL \$ 31.01  
TAXABLE AMOUNT \$ 00  
SEN SALES TAX % 00

This amount is an estimate at time of shipping prior to any adjustments made at delivery: \$ 31.01

000  
240-1340 = 31.01

ACCOUNT INVOICE INVOICE CUSTOMER PURCHASE ORDER  
 NO. NO. DATE NO. NUMBER  
 91221190 2337625 01/14/25 11221140

SALES SALES DATE  
 LOC. REF. ORDERED  
 3055 0832 01/12/25

Route: 2314 / 4

ORDER NUMBER: 40732

Bill To: 50 VILLAGE COMM DEV DISTR  
 3989 EAGLE LANDING PKWY  
 ORANGE PARK FL  
 32065  
 Att: CHRIS COLLETTI

Ship To: TRN EAGLE LANDING GLF CLB  
 3989 EAGLE LANDING PKWY  
 ORANGE PARK FL  
 32065  
 904 291 5600  
 DEPT # 00

Remit To: US Foods, Inc.  
 P O BOX 195421  
 ATLANTA GA  
 30384-8421  
 888 763 1304

Ship From: 5425 S. WILLIAMSON BLVD FORT ORANGE FL Ship Date: 01/14/25 Page 01 of 03  
 Terms: NET 21 DAYS  
 Driver MUST LEAVE FINAL RECEIPT FOR INV CHANGE

Qty Ordered	Qty Shipped	Sales Unit	Product Number	Description	Pack Size	Label	Weight	Pricing Unit	Unit Price	Extended Price
-------------	-------------	------------	----------------	-------------	-----------	-------	--------	--------------	------------	----------------

1	CS	4667494	REFRIGERATED LIME, #1 GRD 48 CT REF 200 SZ 48 EA	CROSS VALY				CS	21.0600	21.06
---	----	---------	--	------------	--	--	--	----	---------	-------

STORAGE LOCATION RECAP(N)

TOTAL REFRIGERATED	PIECES ORDERED:	1	PIECES SHIPPED:	1	ITEMS SHIPPED:	1	21.06	
TOTAL NET WGT:	10.00	*** INVOICE SUMMARY ***	PIECES ORDERED:	1	PIECES SHIPPED:	1	ITEMS SHIPPED:	1
TOTAL GROSS WGT:	10.50							

\*\*\*\*\*  
 \* Federal Occupation Safety and Health Standards Section 1910.1200 on Hazard  
 \* Communication requires manufacturers and distributors to provide Material  
 \* Safety Data Sheets on non-food products defined to be hazardous. Products  
 \* such as cleaning products and pesticides are included in the scope of the  
 \* Standard. In compliance with the law, MSDS are available to US Foods, Inc.  
 \* customers and can be obtained by contacting the Procurement Manager in our  
 \* district office or by advising your sales representative.  
 \* You may contact HAZMAT HOTLINE at phone # (800) 424 - 0802.  
 \*  
 \*\*\*\*\*

TAXABLE AMOUNT \$ 10.00  
 GEN SALES TAX % 21.06

PRODUCT TOTAL \$ 21.06

This amount is an estimate at time of shipping prior to any adjustments made at delivery: \$ 21.06

*[Handwritten Signature]*  
 1/21/25

000  
 240-1340 = 21.06



# VENDOR SHIP INVOICE

ACCOUNT NUMBER	INVOICE NUMBER	INVOICE DATE	CUSTOMER NUMBER	PURCHASE ORDER #	SALES LOCATION	SALES REP	DATE ORDERED
91221150	2465188	01/16/2025	11221140		3055	832	01/11/2025
FREIGHT TERMS	ORDER NUMBER	PAYMENT TERMS	ROUTE NUMBER	SPECIAL INSTRUCTIONS			
	38985	NET 21 DAYS	0	DRIVER MUST LEAVE FINAL RECEIPT FOR INV CHANGES			

BILL TO	SHIP TO	REMIT TO
SO VILLAGE COMM DEV DISTR 3989 EAGLE LANDING PKWY ORANGE PARK, FL 32065 ATTN: CHRIS COLLETTI (000) 000-0000	TRN EAGLE LANDING GLF CLB 3989 EAGLE LANDING PKWY ORANGE PARK, FL 32065 Dept: 0 (904) 291-5600	US Foods, Inc. P.O. BOX 198421 ATLANTA, GA 30384-8421 (386) 763-1304

**SHIPPED FROM:** **DRIVER NAME:** **ROUTE NUMBER:** 0  
**SHIPPED DATE:** 01/16/2025 **DRIVER ID:** **STOP NUMBER:** 0

INVOICE LINE DETAILS											
QUANTITY		SALES UNIT	PRODUCT NUMBER	DESCRIPTION	LABEL	PACK SIZE	CODE	WEIGHT	PRICING UNIT	UNIT PRICE	EXTENDED PRICE
ORD	SHIP										
DRY											
1	1	CS	1993153	CRAYON, 3 PK ASST RED BLU GRN <i>Shipment Tracking: 401588578386, FEDEX</i>	HOFFMASTER	500/3 EA			CS	\$85.4500	\$85.45

STORAGE LOCATION RECAP(N)					
STORAGE LOCATION	TOTAL PIECES ORDERED	TOTAL PIECES SHIPPED	TOTAL ITEMS SHIPPED	TOTAL WEIGHT SHIPPED	TOTAL EXTENDED PRICE
DRY	1	1	1	17.08	\$85.45
<b>DELIVERY SUMMARY TOTALS</b>	<b>1</b>	<b>1</b>	<b>1</b>	<b>17.08</b>	<b>\$85.45</b>

INVOICE SUMMARY			
<b>TOTAL NET WEIGHT SHIPPED</b>	17.08	Product Total	\$85.45
<b>TOTAL GROSS WEIGHT SHIPPED</b>	17.58	Sales Tax	\$0.00
		<b>PLEASE REMIT THIS AMOUNT BY</b> 02/06/2025	<b>\$85.45</b>

500-7450 = 85.45

ACCOUNT INVOICE INVOICE CUSTOMER PURCHASE ORDER  
 NO. NO. DATE NO. NUMBER  
 91221150 2483896 01/17/25 11221140

SALES SALES DATE  
 LOC. REP. ORDERED  
 3055 0832 01/16/25

Route: 5321 / 7

ORDER NUMBER: 51923

Bill To: SO VILLAGE COMM DEV DISTR  
 3989 EAGLE LANDING PKWY  
 ORANGE PARK FL  
 32065  
 Att: CHRIS COLLETTI

Ship To: TRN EAGLE LANDING CLF CLS  
 3989 EAGLE LANDING PKWY  
 ORANGE PARK FL  
 32065  
 904 291 5600  
 DEPT # 00

Remit To: US Foods, Inc.  
 P.O. BOX 198421  
 ATLANTA GA  
 30384-8421  
 386 763 1304

Ship From: 5425 S. WILLIAMSON BLVD PORT ORANGE  
 Frt Terms:  
 Del Terms: NET 21 DAYS  
 Qty Qty Sales Product Description  
 Ordered Shipped Unit Number

FL Ship D: 01/17/25 Page 01 of 03  
 Special DRIVER MUST LEAVE FINAL RECEIPT FOR INV CHANGE  
 Instr:  
 Pack Size Label C Weight Pricing Unit Extended  
 D Price Price

1	1	CS	3746382	FROZEN CATFISH, BRDD 2-2.5 Z STRIP	3/5 LB	GUIDRY'S	CS	101.1000	\$	101.10
---	---	----	---------	------------------------------------	--------	----------	----	----------	----	--------

STORAGE LOCATION RECAP(N)

TOTAL FROZEN	PIECES ORDERED:	1	PIECES SHIPPED:	1	ITEMS SHIPPED:	1	101.10
--------------	-----------------	---	-----------------	---	----------------	---	--------

TOTAL NET WGT:	15.00	*** INVOICE SUMMARY ***	PIECES ORDERED:	1	PIECES SHIPPED:	1	ITEMS SHIPPED:	1
TOTAL GROSS WGT:	15.10							

\*\*\*\*\*  
 \* PRODUCT TOTAL \$ 101.10  
 \* Federal Occupation Safety and Health Standards. Section 1910.1200 on Hazard  
 \* Communication requires manufacturers and distributors to provide Material  
 \* Safety Data Sheets on non-food products defined to be hazardous. Products  
 \* such as cleaning products and pesticides are included in the scope of the  
 \* Standard. In compliance with the law. MSDS are available to US Foods, Inc.  
 \* customers and can be obtained by contacting the Procurement Manager in our  
 \* district office or by advising your sales representative.  
 \* You may contact HAZMAT HOTLINE at phone #(800) 424 - 8802.  
 \*  
 \* TAXABLE AMOUNT \$ 00  
 \* GEN SALES TAX % 00  
 \*  
 \* \*\*\*\*\*

This amount is an estimate at time of shipping prior to any adjustments made at delivery: \$ 101.10

*[Handwritten signature]*  
 1/21/25

000  
 240-1340=101.10

ACCOUNT INVOICE INVOICE CUSTOMER PURCHASE ORDER  
 NO. NO. DATE NO. NUMBER  
 91221150 2483895 01/17/25 11221140

SALES SALES DATE  
 LOC. REP. ORDERED  
 3055 0832 01/16/25

Route: 5321 / 7

ORDER NUMBER: 51096

Bill To: SO VILLAGE COMM DEV DISTR  
 3989 EAGLE LANDING PKWY  
 ORANGE PARK FL  
 32065  
 Att: CHRIS COLLETTI

Ship To: TRN EAGLE LANDING GLF CLB  
 3989 EAGLE LANDING PKWY  
 ORANGE PARK FL  
 32065  
 904 291 5600  
 DEPT # 00

Remit To: US Foods, Inc.  
 P.O. BOX 198421  
 ATLANTA GA  
 30384-8421  
 386 763 1304

Ship From: 5425 S. WILLIAMSON BLVD PORT ORANGE FL Ship Date: 01/17/25 Page 02 of 04  
 Frt Terms: Special DRIVER MUST LEAVE FINAL RECEIPT FOR INV CHANGE  
 Pmt Terms: NET 21 DAYS Instr:

Qty	Qty	Sales	Product	Description	Pack	Size	Label	C	Weight	Pricing	Unit	Extended
Ordered	Shipped	Unit	Number					D		Unit	Price	Price

2	2	CS	6553758	ROLL, KSR WHT 4.5" SLCD BKD	6/8/3.5 OZ		ROTELLA			CS	31.6600	63.32
1	1	CS	6602296	GUACAMOLE, POUCH FZN SUPRM	4/3 LB		DEL PASO			CS	60.0700	60.07
1	1	CS	6681308	BAGEL, ASST 4 Z SLCD THAW &	12/6/4 OZ		BURRY FOOD			CS	31.8700	31.87
3	3	CS	7637713	CHICKEN, TNDLN BTRD FRTR BEER	2/5 LB		PATUXENT			CS	39.9600	119.88
1	1	CS	8131864	BEEF, GRND 80/20 FINE RAW FZN	4/5 LB		AVENDRA			CS	83.5200	83.52
1	1	CS	9205147	BEEF, PTY GRND 75/25 3:1 HMSTY	60/5.33 OZ		TMTSTYTND			CS	85.0000	85.00

STORAGE LOCATION RECAP(N)

TOTAL DRY	PIECES ORDERED:	17	PIECES SHIPPED:	17	ITEMS SHIPPED:	15	702.00
TOTAL REFRIGERATED	PIECES ORDERED:	16	PIECES SHIPPED:	16	ITEMS SHIPPED:	10	885.24
TOTAL FROZEN	PIECES ORDERED:	18	PIECES SHIPPED:	18	ITEMS SHIPPED:	11	942.89

\*\*\* INVOICE SUMMARY \*\*\*  
 TOTAL NET WGT: 946.03  
 TOTAL GROSS WGT: 1015.21  
 PIECES ORDERED: 51  
 PIECES SHIPPED: 51  
 ITEMS SHIPPED: 36

\*\*\*\*\*  
 \* PRODUCT TOTAL \$ 2530.13

\* Federal Occupation Safety and Health Standards. Section 1910.1200 on Hazard  
 \* Communication requires manufacturers and distributors to provide Material  
 \* Safety Data Sheets on non-food products defined to be hazardous. Products  
 \* such as cleaning products and pesticides are included in the scope of the  
 \* Standard. In compliance with the law. MSDS are available to US Foods, Inc.  
 \* customers and can be obtained by contacting the Procurement Manager in our  
 \* district office or by advising your sales representative.  
 \* You may contact HAZMAT HOTLINE at phone # (800) 424 - 8802.

TAXABLE AMOUNT \$ .00  
 GEN SALES TAX % .00  
 1460-000 -24.88  
 1470-000 24.88

This amount is an estimate at time of shipping prior to any adjustments made at delivery: \$ 2530.13

000  
~~240~~-1340 = 2336.07  
 240-7450 = 160.15  
 240-7444 = 9.03  
 200-5500 = 24.88  
 Total = 2530.13



ACCOUNT INVOICE INVOICE CUSTOMER PURCHASE ORDER SALES SALES DATE  
 NO. NO. DATE NO. NUMBER LOC. REP. ORDERED  
 91221150 2483895 01/17/25 11221140 3055 0832 01/16/25

Route: 5321 / 7 ORDER NUMBER: 51096

Bill To: SO VILLAGE COMM DEV DISTR  
 3989 EAGLE LANDING PKWY  
 ORANGE PARK FL 32065  
 Att: CHRIS COLLETTI

Ship To: TRN EAGLE LANDING GLF CLB  
 3989 EAGLE LANDING PKWY  
 ORANGE PARK FL 32065  
 904 291 5600  
 DEPT # 00

Remit To: US Foods, Inc.  
 P.O. BOX 198421  
 ATLANTA GA 30384-8421  
 386 763 1304

Ship From: 5425 S. WILLIAMSON BLVD PORT ORANGE FL Ship D: 01/17/25 Page 01 of 04  
 Terms: NET 21 DAYS Special: DRIVER MUST LEAVE FINAL RECEIPT FOR INV CHANGE  
 Qty Qty Sales Product Description Pack Size Label C Weight Pricing Unit Extended  
 Ordered Shipped Unit Number

Qty	Qty	Sales	Product	Description	Pack Size	Label	C	Weight	Pricing	Unit	Extended
Ordered	Shipped	Unit	Number				D		Unit	Price	Price
1	1	CS	1017425	DRY							
2	2	CS	1328699	SALSA, THCK & CHNKY MILD SHLF 4/138 OZ		PACE			CS	58.8000	\$ 58.80
1	1	EA	1425990	SHORTENING, FRYG SOYBN LIQ CLR35 LB		HARVEST VL			CS	32.0100	64.02
1	1	CS	2833239	LABEL, FRI 2X2 DSVBL RL GRN 1 RL		DAYMARK			EA	11.1600	11.16
1	1	CS	3554565	CHIP, ASST SS BAG SHLF STABL 2/30 EA		FRITO LAY			CS	41.0800	41.08
1	1	EA	4144478	DRINK, SODA COLA COKE CLSC CAN24/12 OZ		COKE			CS	18.2900	18.29
2	2	CS	5651351	SEASONING, STK MNTRL RUB SHLF 7 LB		MCCORMICK			EA	49.0300	49.03
1	1	CS	6310726	GLOVE, VINYL XL PF CLR AMBOX 10/100 EA		VALUGARDS			CS	21.6700	43.34
1	1	CS	6617609	JUICE, CRNBY DRNK 27% BAR PAC 12/32 OZ		OCEANSPRAY			CS	24.8800	24.88
1	1	CS	6729776	CONTAINER, FM 6X6 1 CMPT WHT 4/125 EA		MONOGRAM			CS	43.3400	43.34
1	1	CS	7013329	KETCHUP, TMTD FCY 33% RED SQZ 16/14 OZ		HEINZ			CS	31.2100	31.21
1	1	EA	8002164	COFFEE, GRND BLU FRCT PK CFNTD192/2 OZ		MAXWELL HS			CS	233.2400	233.24
1	1	CS	8625717	SAUCE, SOY PLST JUG SHLF STABL1 GA		KIKKOMAN	h		EA	12.2700	12.27
1	1	CS	9009234	LID, CUP SFLE 3.25-5.5 Z NON 20/125 EA		DART			CS	26.2800	26.28
1	1	CS	9395781	BOWL, 8 Z FM WHT 20/50 EA		DART			CS	36.0300	36.03
1	1	CS	9395781	SCRUBBER, SYTHC FIBR 6X9 GRN 20 EA		NIAGARA			CS	9.0300	9.03
											clean
				REFRIGERATED							
1	1	CS	0823013	EGG, SHL LG GRD AA WHT LOOS PK15 OZ		GLNVW FRMS			CS	99.1700	99.17
1	1	CS	2326411	LETTUCE, ICEBRG FRESH REF BOX 24 EA		CROSS VALY			CS	28.9100	28.91
4	4	CS	2721173	CHICKEN, WING 1&2JT JMB RAW 4/10 LB		PATUXENT			CS	94.1200	376.48
1	1	CS	2725711	CHICKEN, BRST SNGL 6 Z BNLS 4/5 LB		PATUXENT			CS	68.0800	68.08
1	1	CS	3340510	CHEESE, AMER SLCD 120 CT TFF 4/5 LB		GLNVW FRMS			CS	51.4600	51.46
1	1	CS	5326418	LETTUCE, RMN FRESH REF 24 EA		CROSS VALY			CS	31.7000	31.70
4	4	CS	5327275	BEEF, FTY GRND 80/20 2:1 RND 20/8 OZ		CTLMN SLCT			CS	42.0000	168.00
1	1	EA	7331614	CELERY, STICK 4" FRESH REF 4/5 LB		CROSS VALY	h		EA	10.8300	10.83
1	1	CS	9124520	READY TO EAT - Please Refer to Return Policy		KEN'S			CS	46.0800	46.08
1	1	EA	9326430	DRESSING, RANCH HMSTY PLST JAR4/1 GA		CROSS VALY	h		EA	4.5300	4.53
1	1	EA	9326430	READY TO EAT - Please Refer to Return Policy		CROSS VALY	h		EA	4.5300	4.53
1	1	CS	1475608	FROZEN							
5	5	CS	2883130	BREAD, FLAT 5X13" OVAL BKD FZN36/3.61 OZ		STONEFIRE			CS	26.1600	26.16
1	1	CS	3200145	POTATO, FF SC 3/8" EXTRA CRSPY6/5 LB		MONARCH			CS	50.1300	250.65
1	1	CS	3330099	SALMON, ATLNTC 6 Z PTN PBD 3D 10 LB		HARBOR BNK			CS	100.1600	100.16
1	1	CS	4521274	HOT DOG, AB 6:1 6" RLR GRIL 10 LB		PATUXENT			CS	30.8600	30.86
1	1	CS	4521274	BEEF, STK SLCD 1/4" CHO NTRL 2/5 LB		CTLMN SLCT			CS	91.4000	91.40



Wesco Turf, Inc.  
2101 Cantu Court  
Sarasota, FL 34232-6240  
(941) 377-6777

Invoice# 41241862  
Location# 02  
Date 11/27/24  
Page 1 OF 1

\*\* Invoice \*\*  
\*\* Reprint \*\*

310428  
EAGLE LANDING GOLF CLUB  
ATTN:ACCOUNTS PAYABLE  
3989 EAGLE LANDING PARKWAY  
SOUTH VILLAGE CDD  
ORANGE PARK, FL 32065-3530

Ship To:  
EAGLE LANDING GOLF COURSE  
890 OAKLEAF PLANTATION PKWY.  
SOUTH VILLAGE CDD  
ORANGE PARK, FL 32065

1\*3

=====  
CustP/O:JOHN 11/19                      Reps :304 /                      Terms:Net 30 Days  
Ord-Date:11/19/24                      W/B:Tim Strebel                      Order# :21489535  
Billed-Date:11/26/24                      Ship-Via:UPS GROUND  
=====

Product	Description	Open	Ship'd	B/O	Price U/M	Extension
===== Shipment Tracking Reference : 1Z3436820369139435 =====						
FLX55-6-59	CONV, 1.5IN, PC, 59NOZ, TRUJ	3	3	0	176.850 EA	530.55

*Handwritten notes:*  
400-7610  
8  
[Signature]  
1/21/25

Mdse Total	Handling	Misc Chg	Tax	Freight	Dep-amt	Dep-Appld	Invoice Total
530.55	0.00	0.00	0.00	0.00	0.00	0.00	530.55

Important: Acceptance of goods constitutes customer agreement to comply with credit and sales terms and conditions of Wesco Turf, Inc. Shipping errors must be reported within 48 hours of receipt of shipment. Requests for return of merchandise must be made within 30 days of the invoice date. No returns will be accepted without a return goods authorization number. Call customer service to obtain an RGA number. A 15% restocking charge and/or a 10% factory return processing fee will apply according to parts policy. Returns must be in re-sellable condition. A finance charge of 1.5% per month will be added to all past due accounts. A \$10 handling fee will be charged on all returned checks. If an account is placed for collection, buyer agrees to pay all costs of collection, including reasonable attorney fees and costs, whether or not suit is brought.



Wesco Turf, Inc.  
 2101 Cantu Court  
 Sarasota, FL 34232-6240  
 (941) 377-6777

Invoice# 41247264  
 Location# 02  
 Date 01/06/25  
 Page 1 OF 1

\*\* Invoice \*\*

310428  
 EAGLE LANDING GOLF CLUB  
 ATTN:ACCOUNTS PAYABLE  
 3989 EAGLE LANDING PARKWAY  
 SOUTH VILLAGE CDD  
 ORANGE PARK, FL 32065-3530

400-7610  
 1/8/25  
 FF

Ship To:  
 EAGLE LANDING GOLF COURSE  
 890 OAKLEAF PLANTATION PKWY.  
 SOUTH VILLAGE CDD  
 ORANGE PARK, FL 32065

90\*13

CustP/O:JIM 01/06      Reps :304 /      Terms:Net 30 Days  
 Ord-Date:01/06/25      W/B:Dennis Johnson      Order# :21496316  
 Billed-Date:01/06/25      Ship-Via:UPS GROUND

Product	Description	Open	Ship'd	B/O	Price U/M	Extension
Shipment Tracking Reference : 123436820367275694						
1-513051	SWITCH-OPEN, NORMALLY **RLC	2	2	0	15.632 EA	31.26
120-5118	SHAFT-ADJUSTER **2P	2	2	0	40.190 EA	80.38
3296-33	NUT-LOCK, NI **RLC **PP	2	2	0	1.070 EA	2.14
137-6130	SCREW-ADJUSTER, BEDBAR **PP	4	4	0	23.980 EA	95.92
IRRI.FLYER	LYNX TRAINING FLYER APRIL 2025	1	1	0	0.000 EA	0.00
PARTS.FLYERB	COMBO PROMO FLYER JAN - MAR 2025	1	1	0	0.000 EA	0.00
DUCK.FLYER	NEW YEAR DUCK FLYER JAN 2-8, 2025	1	1	0	0.000 EA	0.00

*[Handwritten signature]*  
 1/14/25

\*\*\*\*\*  
 \*\*\* EARLY CLOSING SARASOTA: Closing at 2:45 on Tuesday January 7 \*\*\*

Mdse Total	Handling	Misc Chg	Tax	Freight	Dep-amt	Dep-Appld	Invoice Total
209.70	4.50	0.00	0.00	16.64	0.00	0.00	230.84

Important: Acceptance of goods constitutes customer agreement to comply with credit and sales terms and conditions of Wesco Turf, Inc. Shipping errors must be reported within 48 hours of receipt of shipment. Requests for return of merchandise must be made within 30 days of the invoice date. No returns will be accepted without a return goods authorization number. Call customer service to obtain an RCA number. A 15% restocking charge and/or a 10% factory return processing fee will apply according to parts policy. Returns must be in re-sellable condition. A finance charge of 1.5% per month will be added to all past due accounts. A \$30 handling fee will be charged on all returned checks. If an account is placed for collection, buyer agrees to pay all costs of collection, including reasonable attorney fees and costs, whether or not suit is brought.



Wesco Turf, Inc.  
 2101 Cantu Court  
 Sarasota, FL 34232-6240  
 (941) 377-6777

Invoice# 41247553  
 Location# 02  
 Date 01/07/25  
 Page 1 OF 1

\*\* Invoice \*\*

310428  
 EAGLE LANDING GOLF CLUB  
 ATTN:ACCOUNTS PAYABLE  
 3989 EAGLE LANDING PARKWAY  
 SOUTH VILLAGE CDD  
 ORANGE PARK, FL 32065-3530

440-76110  
 1/10/25  
 JS

Ship To:  
 EAGLE LANDING GOLF COURSE  
 490 TARKLEA PLANTATION PKWY.  
 SOUTH VILLAGE CDD  
 ORANGE PARK, FL 32065

78\*227

CustP/O:GLENN 12/26  
 Ord-Date:12/26/24  
 Billed-Date:12/26/24

Reps :304 /  
 W/B:Tim Strebels  
 Ship-Via:Wesco Turf Truck with

Terms:Net 30 Days  
 Order# :21495308

Product	Description	Open	Ship'd	B/O	Price U/M	Extension
108-1178	PREMIUM ALL SEASON HYD. FLUID (truck only) **PP	1	1	0	102.230 EA	102.23
107-7817	FILTER-OIL, ENGINE **PP	3	3	0	12.790 EA	38.37
94-2690	FILTER-FUEL **PP	5	5	0	4.470 EA	22.35
108-3811	FILTER-AIR V-TWIN HD **PP	3	3	0	20.460 EA	61.38
115-2303	RADIATOR	1	1	0	1010.024 EA	1,010.02
66-3240	CAP-RADIATOR	1	1	0	21.960 EA	21.96
115-1880	BEDKNIFE-EDGEMAX, MICRO CUT (21 **PP	6	6	0	92.600 EA	555.60
93-9774	BEDKNIFE (FAIRWAY) **PP	4	4	0	54.610 EA	218.44
119-4151	SCREW-BEDKNIFE **PP	200	200	0	0.390 EA	78.00
32105-18	SCREW-HHF	1	1	0	0.416 EA	0.42
104-7201	NUT-HF, NI **PP	1	1	0	0.650 EA	0.65
SERVICE.FLYER2	WTU SOLVING SPRAYERS FLYER DECEMBER 2024	1	1	0	0.000 EA	0.00

\*\*\*\*\*  
 \*\*\* EARLY CLOSING SARASOTA: Closing at 2:45 on Tuesday January 7 \*\*\*

Ydse Total	Handling	Misc Chg	Tax	Freight	Dep-amt	Dep-Appld	Invoice Total
2,109.42	4.50	0.00	0.00	0.00	0.00	0.00	2,113.92

Glenn 440-241-9595  
 M-Th 4:30-12:20 F 4:30-9

Important: Acceptance of goods constitutes customer agreement to comply with credit and sales terms and conditions of Wesco Turf, Inc. Shipping errors must be reported within 48 hours of receipt of shipment. Requests for return of merchandise must be made within 30 days of the invoice date. No returns will be accepted without a return goods authorization number. Call customer service to obtain an RGA number. A 15% restocking charge and/or a 10% factory return processing fee will apply according to parts policy. Returns must be in re-sellable condition. A finance charge of 1.5% per month will be added to all past due accounts. A \$30 handling fee will be charged on all returned checks. If an account is placed for collection, buyer agrees to pay all costs of collection, including reasonable attorney fees and costs, whether or not suit is brought.



**ACUSHNET COMPANY**  
 P.O. BOX 965 FAIRHAVEN, MA 02719-0965  
 Tel: 800-225-8500 Fax: 508-979-3913



2275-000

**INVOICE**  
 Currency: USD

Tax No: 04-2591836

Invoice No 919483340		Invoice Date 12/31/24	Shipment Date 12/31/24	Order Date 12/27/24
Order No 3025356178	Whs 05P	Delivery No 60503508	Customer P.O. JOHN SMITH	Account No US00027669 \ US00040574

**Sold To**  
 SOUTH VILLAGE COMMUNITY DEVELOP  
 DISTRICT DBA EAGLE LANDING GOLF CLUB  
 3989 EAGLE LANDING PKWY  
 ORANGE PARK FL 32065-2641

**Ship To**  
 EAGLE LANDING GOLF CLUB  
 ATTN PRO SHOP  
 3989 EAGLE LANDING PKWY  
 ORANGE PARK FL 32065-2641

**Remit To**  
 Acushnet Company  
 P.O. Box 830334  
 Philadelphia, PA 19182-0334

**Payment Terms**  
 Net 45 Days  
 Payment Discount  
 2% 30 Days  
 Delivery Method  
 FedEx Ground

**Due Date**  
 02/14/25

**Frt Acct No**

Item No	Shipped	U/M	Unit	Disc	Disc	Cstm	Net	Extended
57927 W110	1	PR	\$90.00	4%			\$86.40	\$86.40
FJ Traditions MEN WHT/WHT/NVY Tag For: John Smith								
Total Shipped Qty. 1								

**Net Order Total** \$86.40  
**Shipping and Handling Total** \$9.74  
**Total Invoice** \$96.14

If paid by 01/30/25 deduct discount of \$ 1.73 ( 2.00 % ) -- REMIT \$94.41

1320-100

Invoices not paid within thirty (30) days of due date shall incur a service charge at the rate of the lesser of one and one-half percent (1.5%) per month or the highest rate permitted by law on any outstanding overdue balance from original due date. SEE REVERSE SIDE FOR CONDITIONS OF SALE.

## Betsy Anderson

---

**From:** sales@eFileMyForms.com  
**Sent:** Tuesday, January 28, 2025 9:38 AM  
**To:** Betsy Anderson  
**Subject:** eFileMyForms - Order Confirmation



# Order Received

Form 1099  
FILING

Thank you for using eFileMyForms.

This email confirms that your order has been received. Your credit card will show a charge from "EFILE8664838131" for the amount of your order.

### The Next Steps:

- All eFileMyForms orders are processed immediately and cannot be canceled after they have been placed. If you need to modify or correct a filing, please visit our Help Center to learn how to make edits and corrections after submitting a form.
- eFileMyForms will email confirmations at each step that pertains to your order - such as when your forms are printed and mailed, once they are transmitted to the IRS/SSA, when they are accepted/rejected by the IRS/SSA, and finally when your order is complete. You can also check the status of your order by logging into your account and clicking on the order number in your order history.
- Remember to check out the eFileMyForms Help Center for help with additional issues or questions.

### Order Summary:

**Order Number:** 1152195  
**Customer Number:** 200299  
**Order Date:** 1/28/2025  
**Payment Method:** Amex  
**Email:** Betsy.Anderson@Troon.com

### Billing Address

**BRENT T BLAKE**  
**TROON**  
**5962 MOUNTAIN VIEW TRACE**  
**TRUSSVILLE, AL 35173**



**Filings/Forms**

**Form 1099-NEC for 2024:**

**Print/Mail/eFile Service**

**17 @ \$4.39 = \$74.63**

**TIN Check Service for Order #1152195:**

**17 @ \$1.00 = \$17.00**

**Sales Tax: \$7.48**

**Order Total: \$99.11**

If your company requires a W-9 from eFileMyForms, you can download it at [www.1099pro.com/w9](http://www.1099pro.com/w9).

# Order Complete

*Please pay  
Taylor Blake  
\$99.11*

*Eagle Landing*

## Order #1152195 placed on 1/28/2025

### Billing Address

Company TROON  
Name BRENT T BLAKE  
Address 5962 MOUNTAIN VIEW TRACE  
TRUSSVILLE, AL 35173

### Payment

Card Type Amex  
Card Number \*\*\*\*\*4008  
Name on Card BRENT T BLAKE  
Expiration 8/2028

Form	Recipient TIN	Recipient Name	Service	Price
Form 1099-NEC for 2024	XX-XXX7268	Southeast Fitness Repair LLC	Print/Mail/eFile	\$4.39
Form 1099-NEC for 2024	XX-XXX1161	Eugenio Ortizramos	Print/Mail/eFile	\$4.39
Form 1099-NEC for 2024	XX-XXX1548	Henshaw's Tree Service	Print/Mail/eFile	\$4.39
Form 1099-NEC for 2024	XX-XXX0575	Proper Pressure Washing	Print/Mail/eFile	\$4.39
Form 1099-NEC for 2024	XX-XXX9633	Stacie Miglorie	Print/Mail/eFile	\$4.39
Form 1099-NEC for 2024	XX-XXX3598	Sun Power Lawn Care LLC	Print/Mail/eFile	\$4.39
Form 1099-NEC for 2024	XX-XXX6678	Williams Manufacturing, Inc.	Print/Mail/eFile	\$4.39
Form 1099-NEC for 2024	XX-XXX2027	New Day Services Inc	Print/Mail/eFile	\$4.39
Form 1099-NEC for 2024	XX-XXX2695	T&M Electric of Clay County, LLC	Print/Mail/eFile	\$4.39
Form 1099-NEC for 2024	XX-XXX7396	W.W. Gay Mechanical Contractor, Inc.	Print/Mail/eFile	\$4.39
Form 1099-NEC for 2024	XX-XXX9346	Real Floors Inc.	Print/Mail/eFile	\$4.39
Form 1099-NEC for 2024	XX-XXX0007	Bounce It Out Events	Print/Mail/eFile	\$4.39
Form 1099-NEC for 2024	XXX-XX-5120	Colbert Murphy	Print/Mail/eFile	\$4.39
Form 1099-NEC for 2024	XXX-XX-9308	Gregory M. Schultz	Print/Mail/eFile	\$4.39
Form 1099-NEC for 2024	XXX-XX-6174	Elizabeth Jackson	Print/Mail/eFile	\$4.39
Form 1099-NEC for 2024	XX-XXX3762	Golf Genius Software	Print/Mail/eFile	\$4.39
Form 1099-NEC for 2024	XX-XXX7403	The Tree Amigos Outdoor Services LLC	Print/Mail/eFile	\$4.39
TIN Check Service for Order #1152195			TIN Check	\$17.00

Taxes: \$7.48

Order Total: \$99.11





2931 PACES FERRY ROAD, SUITE 100, ATLANTA, GA 30339  
 (770) 438-7955 • (770) 438-6477 • Toll Free 877-BULK-AGG • www.bulkagg.com

# INVOICE

Bill To:

Ship To:

EAGLE LANDING GOLF CLUB  
 3989 EAGLE LANDING PARKWAY  
 ORANGE PARK, FL 35065

GOLF MAINTENANCE  
 3989 EAGLE LANDIG PKWY  
 ORANGE PARK, FL

Terms	Job Number	Customer	P.O. Number	Date	Invoice#	Page
NET 30 DAYS		9659		11/13/2024	00077261	1

Date	Ticket	Order	Material	Tons	Rate	Amount
11/12/2024	738988	054074	LSEM DYED GREEN	29.42	32.00	941.44
			FREIGHT	29.42	24.00	706.08
			TOTAL TONS	29.42		
			TOTAL MATERIAL			941.44
			TOTAL FREIGHT			706.08
			PLEASE PAY THIS AMOUNT =====>			1,647.52

*4W-7770*  
*8*  
*[Signature]*  
*1/29/25*

Payment due according to terms of this invoice.  
 Any amounts not paid when due shall be subject to a service charge of 1.5% per month (18% annually).  
 In the event any amounts are collected by law, as through an attorney at law, the customer shall be  
 obligated to pay all costs of collection, including attorney fees in the amount of 15% of the amount so collected.



\*3% convenience fee for credit card charges will be applied

(customer copy)



**CONTRACT INVOICE**

Invoice Number: 474175  
 Invoice Date: 01/13/2025

**Bill To:** South Village Community Development District dba Eagle Landing Golf Club  
 3989 Eagle Landing Parkway  
 Orange Park, FL 32065

**Customer:** South Village Community Development District dba Eagle Landing Golf Club  
 3989 Eagle Landing Parkway  
 Orange Park, FL 32065

Account No	Payment Terms	Due Date	Invoice Total	Balance Due	
SV00	Net 30	02/12/2025	\$ 165.93	<b>\$ 165.93</b>	
<b>Invoice Remarks</b>					
Contract Number	Contact	Contract Amount	P.O. Number	Start Date	Exp. Date
SV00-01	Joe Halifko 904-291-5600 #3 #6	\$ 165.93		02/13/2018	
<b>Contract Remarks</b>					
Lease includes 3,000 b/w copies per month.					

**Summary:**

Contract base rate charge for this billing period	\$0.00
Contract overage charge for the 12/13/2024 to 01/12/2025 overage period	\$159.98 **
Supply Shipping	\$5.95

**Detail:**

**Equipment included under this contract**

**Konica Minolta/C368**

Number	Serial Number	Base Adj.	Location
EQ16935	A7PU017004327	\$0.00	South Village Community Development District dba Eagle Landing Golf Club 3989 Eagle Landing Parkway Orange Park, FL 32065

Meter Type	Meter Group	Begin Meter	End Meter	Credits	Total	Covered	Billable	Rate	Overage
B/W	EQ16935 - B/W	184,029	185,805		1,776	3,000	0	\$0.013000	\$0.00
Color	EQ16935 - Colr	179,056	180,640		1,584	0	1,584	\$0.101000	\$159.98
									\$159.98

*Handwritten notes:*  
 SW-7340  
 06  
 [Signature]  
 1/13/25

Tax ID#26-3755218  
 DUNS #004769165

Thank you for your business!

Invoice Subtotal:	\$165.93
EX	\$0.00
Total Tax:	\$0.00
<b>Invoice Total:</b>	<b>\$165.93</b>



REMIT PAYMENT TO:  
 CINTAS CORP  
 P.O. BOX 630910  
 CINCINNATI, OH 45263-0910

VIEW & PAY YOUR BILLS ONLINE:  
 WWW.CINTAS.COM/MYACCOUNT

CUSTOMER SVC/BILLING 833-290-0514  
 CINTAS FAX # 904-741-6116  
 PAYMENT INQUIRY 904-741-4525

INVOICE

SHIP TO: EAGLE LANDING GOLF CLUB  
 3989 EAGLE LANDING PKWY  
 ORANGE PARK, FL 32065-2641

INVOICE # 4218543409  
 INVOICE DATE 01/21/2025  
 CUSTOMER REF # SOUTH VILLAGE  
 COMMUNITY DEVT DISTR

BILL TO: EAGLE LANDING GOLF CLUB  
 3989 EAGLE LANDING PKWY  
 ORANGE PARK, FL 32065-2641

SOLD TO # 22390656  
 PAYER # 22385762  
 PAYMENT TERMS NET 10 EOM  
 SORT # 02800003369  
 CINTAS ROUTE 53 / DAY 2 / STOP 010

ENPS/LOCK#	MATERIAL	DESCRIPTION	FREQ	EXCH	QTY	UNIT PRICE	LINE TOTAL	TAX
	X20023	SIG HRDWRD WHT LRG-	01	F	12	9.520	114.24	N
	X2709	TERRY TOWEL - WHITE-	01	F	320	0.202	64.64	N
	X2708	TERRY TOWEL - WHITE-	L 01	F	29	0.601	17.43	N
	X27026	SIG AIR SVC	01	F	21	3.867	81.21	N
	X27097	SIG TRASHCAN DSP ALU-	01	F	24	1.190	28.56	N
	X2873	BIB APRON-BLACK-	01	F	60	0.444	26.64	N
	X2873	BIB APRON-BLACK-	L 01	F	1	9.261	9.26	N
	X6680	DISP URINAL MAT SVC	01	F	9	2.380	21.42	N
	X9110	JRT TOILET TISSUE REFILL-	01	F	12	4.760	57.12	N
	X9213	SANIS SCREEN SERVICE	01	F	9	2.380	21.42	N
		SUBTOTAL					441.94	
1460-000	-131.05	SERVICE CHARGE						
1470-000	131.05							
		SUBTOTAL					449.02	
		TAX					(0.00)	
		TOTAL USD					449.02	

SUBTOTAL ~~441.94~~ LINES  
 240-7465-117.97

- cps supply -  
 200-31.05  
 240-120.00  
 400-80.00  
 600-100.00

TOTAL ADJUST.  
 TAX ADJUST.  
 NET TOTAL

Purchase Employee gifts or company swag through account cintas.com and use code SMOPLAUNCH for 10% off your \*first online order of \$150 or more. \* Promotion ends 1/31/2025.

*Rec'd 1/21/25*

CUSTOMER TOTAL CURRENT: 898.91 PAST DUE: 961.33 30 DAYS: 0.00 60 DAYS: 0.00 90+ DAYS: 0.00

FOR ALL NON-PAYMENT RELATED CORRESPONDENCE : CINTAS CORPORATION #0280 / 1595 TRANSPORT CT., / JACKSONVILLE, FL 32218



REMIT PAYMENT TO: CINTAS CORP  
 P.O. BOX 630910  
 CINCINNATI, OH 45263-0910

VIEW & PAY YOUR BILLS ONLINE:  
 WWW.CINTAS.COM/MYACCOUNT

CUSTOMER SVC/BILLING 833-290-0514  
 CINTAS FAX # 904-741-6116  
 PAYMENT INQUIRY 904-741-4525

INVOICE

SHIP TO: EAGLE LANDING GOLF CLUB  
 3989 EAGLE LANDING PKWY  
 ORANGE PARK, FL 32065-2641

INVOICE # 4219270748  
 INVOICE DATE 01/28/2025  
 CUSTOMER REF # SOUTH VILLAGE  
 COMMUNITY DEVT DISTR

BILL TO: EAGLE LANDING GOLF CLUB  
 3989 EAGLE LANDING PKWY  
 ORANGE PARK, FL 32065-2641

SOLD TO # 22390656  
 PAYER # 22385762  
 PAYMENT TERMS NET 10 EOM  
 SORT # 02800003369  
 CINTAS ROUTE 53 / DAY 2 / STOP 010

ENPS/LOCK#	MATERIAL	DESCRIPTION	FREQ	EXCH	QTY	UNIT PRICE	LINE TOTAL	TAX
	X20023	SIG HRDWD WHT LRG-	01	F	12	9.520	114.24	N
	X2700	TERRY TOWEL - WHITE-	01	F	320	0.202	64.64	N
	X2700	TERRY TOWEL - WHITE-	L 01	F	29	0.601	17.43	N
	X27026	SIG AIR SVC	01	F	21	3.867	81.21	N
	X27029	SIG AIR RFL CITRUS-	04	F	27	0.000	0.00	N
	X27097	SIG TRASHCAN DSP ALU-	01	F	24	1.190	28.56	N
	X2873	BIB APRON-BLACK-	01	F	60	0.444	26.64	N
	X2873	BIB APRON-BLACK-	L 01	F	1	9.261	9.26	N
	X6680	DISP URINAL MAT SVC	01	F	9	2.380	21.42	N
	X7464	DISP URINAL MAT RFL-	04	F	9	0.000	0.00	N
	X9110	JRT TOILET TISSUE REFILL-	01	F	12	4.760	57.12	N
	X9213	SANIS SCREEN SERVICE	01	F	9	2.380	21.42	N
	X9239	SAN SCR N CLN DRZ RFL-	04	F	9	0.000	0.00	N
SUBTOTAL							441.94	
SERVICE CHARGE							7.08	N
SUBTOTAL							449.02	
TAX							(0.00)	
TOTAL USD							449.02	

1460-000 -131.05  
 1470-000 131.05

*Zero off 1/28/25*

*[Signature]*  
 1/28/25

TOTAL ADJUST. \_\_\_\_\_  
 TAX ADJUST. \_\_\_\_\_  
 NET TOTAL \_\_\_\_\_

Imen -  
 240-7465 \$117.97

*as apply*  
 200-7440 - 31.05  
 240-7440 - 100.00  
 400-7440 - 100.00  
 600-7440 - 100.00



## HELGET GAS PRODUCTS

4211 S 102ND STREET  
 OMAHA, NE 68127-0000  
 Phone: (866) 814-1554

Manage your account & pay invoices online at:  
[www.helgetgas.com](http://www.helgetgas.com)

Date: Monday, January 27, 2025  
 Order #: 0002919226-00  
 Arrival: 2:53 PM  
 Departure: 3:22 PM  
 Branch: 000730  
 Customer: 50980 - EAGLE LANDING GOLF CLUB  
 Bill-to: SOUTH VILLAGE COMMUNITY DEVELOPMENT DISTRICT  
 3989 EAGLE LANDING PKWY  
 ORANGE PARK, FL 32065-0000  
 Ship-to: 3989 EAGLE LANDING PKWY  
 ORANGE PARK, FL 32065-0000  
 Emailed to: jhalifko@troon.com  
 Stop #: 13  
 Device ID: 26744ae8-ebbe-486f-82c7-2e90b29aef6a

**\* Hardgoods \***

Item	UOM	Qty
DC 82010	EA (1)	1
Loc: 730		
FS 82000	EA (1)	1
Loc: 730		

**\* Cylinders \***

Item	UOM	Qty
C2 CARB-BULKF	LB (1)	100
UN2187		
NON-FLAMMABLE		
CO2 BULK FILL - FLAT RATE		
CARBON DIOXIDE, REFRIGERATED LIQ		
Lot #: 73001272501 (100)		
Loc: 730		
BB 36504	EACH (1)	2
UN1956		
NON-FLAMMABLE		
K 25%CO2/75%N2 BEER BLEND		
COMPRESSED GAS, N.O.S.		
Ships: 2		
Lot #: 124014250503 (2)		
Returns: 3		
Loc: 730		

240-7700  
 [Signature]  
 1/27/25

**Total Ships: 2 Total Returns: 3**

**\* Payment Summary \***

Item	Qty	Amount
DC 82010	1 @ \$25.95	\$25.95
FS 82000	1 @ \$4.95	\$4.95
C2 CARB-BULKF	100 @ \$0.00000	\$0.00
BB 36504	2 @ \$56.16	\$112.32
<b>Subtotal</b>		<b>\$143.22</b>

GOLF - GOLF SHOP

Receiving SKUs into Inventory - Audit RC1627

Date of Record: Jan 28, 2025

Supplier: ACUSHNET COMPANY

Reference: 919576807 Audit Number: RC1627

SKU #	Prod.ID Description	Stock Loc'n	Quantity	Unit Cost	Amount
02FJ75	FJ Men's Polo (Last Cost: 44.07)	MAIN	30.00	45.06	1351.80
Totals (1 SKUs )			30.00		1351.80

G/L Summary Postings

9I-1320-000	919576807	Inventory - Soft Goods	1,351.80
9I-2275-000	919576807	Accrued Merchandise Invento	-1,351.80
Difference:			0.00

\*\*\*\*\* End of Report \*\*\*\*\*

**MARTCO**  
P.O. BOX 23160  
JACKSONVILLE, FL 32241

**INVOICE**

125224

DATE: 1/14/2025  
INVOICE NO.: 125224

(904) 733-4905

BILL TO:

**EAGLE LANDING GOLF CLUB**  
**3989 EAGLE LANDING PKWY**  
**ORANGE PARK, FL. 32065**

SHIP TO:

291-5600

*This amount is not for business!*

P.O. NUMBER	TERMS	REP	SHIP	VIA	F.O.B.	PROJECT
-------------	-------	-----	------	-----	--------	---------

CHEF BRYAN	Net 30	PETE	1/15/2025	MARTCO	DEST	
------------	--------	------	-----------	--------	------	--

QUANTITY	ITEM CODE	DESCRIPTION	PRICE EACH	AMOUNT
----------	-----------	-------------	------------	--------

4	318XHI	THERMAL REGISTER PAPER-50 RLS/230'	67.80	271.20'
2	300WC	KITCHEN PRINTER PAPER ROLLS, 2-PLY	54.80	109.60'
24	52030BR	KITCHEN PRINTER RIBBONS	3.20	76.80'
		SUB TOTAL		457.60
		Sales Tax	7.50%	<del>34.32</del>

*1/21/25*  

*Do NOT pay tax*

*PAID \$457.60*

*Bryant*

*500-7450=491.92*

<b>TOTAL</b>	<b>\$491.92</b>
--------------	-----------------



ODP Business Solutions, LLC  
 PO BOX 7241  
 SIOUX FALLS SD  
 57117-7241

ORIGINAL INVOICE

10000

THANKS FOR YOUR ORDER

IF YOU HAVE ANY QUESTIONS  
 OR PROBLEMS. JUST CALL US

FOR CUSTOMER SERVICE ORDER: (888) 263-3423  
 FOR ACCOUNT: (800) 721-6592

FEDERAL ID:86-2161688

INVOICE NUMBER	AMOUNT DUE	PAGE NUMBER
403863647001	111.84	Page 1 of 1
INVOICE DATE	TERMS	PAYMENT DUE
07-JAN-25	Net 30	09-FEB-25

BILL TO:

ATTN: ACCTS PAYABLE  
 EAGLE LANDING GOLF COURSE  
 3989 EAGLE LANDING PKWY  
 ORANGE PARK FL 32065-2641

003022-000378

SHIP TO:

EAGLE LANDING GOLF COURSE  
 3989 EAGLE LANDING PKWY  
 ORANGE PARK FL 32065-2641



ACCOUNT NUMBER	PURCHASE ORDER	SHIP TO ID	ORDER NUMBER	ORDER DATE	SHIPPED DATE		
15779562		3989EAGLELANDINGPKWY	403863647001	04-JAN-25	07-JAN-25		
BILLING ID	ACCOUNT MANAGER	RELEASE	ORDERED BY	DESKTOP	COST CENTER		
21782146			JOE MALIFKO				
CATALOG ITEM #/ MANUF CODE	DESCRIPTION/ CUSTOMER ITEM #	U/W	QTY ORD	QTY SHP	QTY B/O	UNIT PRICE	EXTENDED PRICE
991992 83140	CLIPBOARD,LTR,9X12-1/2 991992	EA	4	4	0	1.190	4.76
6028288 4143	PAPER,OD 6028288	CT	1	1	0	52.730	52.73
865843 115078	BANDAID,FLEXIBLE,ASTD,100B 865843	EA	1	1	0	8.880	8.88
7258216 NMC01205CT	REMOVER,STAIN,PEN,TIDE 2 7258216	CT	1	1	0	30.990	30.99
307928 89465A	PEN,PROFILE,PM,BOLD,DZ,BL 307928	DZ	1	1	0	14.480	14.48

*Handwritten notes:*  
 SW-7450  
 1/20/25

SUB-TOTAL	111.84
DELIVERY	0.00
SALES TAX	0.00
TOTAL	111.84

All amounts are based on USD currency

To return supplies, please repack in original box and insert our packing list, or copy of this invoice. Please note problem so we may issue credit or replacement, whichever you prefer. Please do not ship collect. Please do not return furniture or machines until you call us first for instructions. Shortage or damage must be reported within 5 days after delivery.

DETACH HERE

CUSTOMER NAME	BILLING ID	INVOICE NUMBER	INVOICE DATE	INVOICE AMOUNT	AMOUNT ENCLOSED
EAGLE LANDING GOLF COURSE	21782146	403863647001	07-JAN-25	111.84	

FL0 217821461 4038636470011 00000011184 1 0

Please  
 Send Your  
 Check to:

ODP Business Solutions, LLC  
 PO Box 1413  
 Charlotte NC 28201-1413

Please return this stub with your payment to  
 ensure prompt credit to your account.

Please DO NOT staple or fold. Thank You.



ODP Business Solutions, LLC  
 PO BOX 7241  
 SIOUX FALLS SD  
 57117-7241

ORIGINAL INVOICE

10000

THANKS FOR YOUR ORDER

IF YOU HAVE ANY QUESTIONS  
 OR PROBLEMS, JUST CALL US  
 FOR CUSTOMER SERVICE ORDER: (888) 263-3423  
 FOR ACCOUNT: (800) 721-6592

FEDERAL ID:86-2161688

INVOICE NUMBER	AMOUNT DUE	PAGE NUMBER
407484053001	107.31	Page 1 of 1
INVOICE DATE	TERMS	PAYMENT DUE
17-JAN-25	Net 30	16-FEB-25

BILL TO:

ATTN: ACCTS PAYABLE  
 EAGLE LANDING GOLF COURSE  
 3989 EAGLE LANDING PKWY  
 ORANGE PARK FL 32065-2641

SHIP TO:

EAGLE LANDING GOLF COURSE  
 3989 EAGLE LANDING PKWY  
 ORANGE PARK FL 32065-2641

002815-000352



ACCOUNT NUMBER	PURCHASE ORDER	SHIP TO ID	ORDER NUMBER	ORDER DATE	SHIPPED DATE
15779562		3989EAGLELANDINGPKWY	407464053001	16-JAN-25	17-JAN-25
BILLING ID	ACCOUNT MANAGER	RELEASE	ORDERED BY	DESKTOP	COST CENTER
21782146			JOE HALIFKO		

CATALOG ITEM #/ MANUF CODE	DESCRIPTION/ CUSTOMER ITEM #	U/M	QTY ORD	QTY SHP	QTY B/O	UNIT PRICE	EXTENDED PRICE
458621 91904	PAPER,65#C,98B,250PK,B/WHI 458621	PK	1	1	0	12.770	12.77
810838 1002549	FOLDER,LTR,1/3CUT,100BX,M 810838	BX	1	1	0	20.500	20.50
543397 OD753 1-3	MANILA FF,LGL,1/3 CUT 543397	BX	1	1	0	25.730	25.73
6826483 EV202116	Plastic Clipboard Clear 6826483	EA	4	4	0	2.180	8.72
366156 65270	TRAY,LTR,STACKABLE,6/PK,B 366156	PK	1	1	0	23.990	23.99
541545 688400	Forever Stamp - Book of 20 541545	EA	1	1	0	14.600	14.60
357914 PRCSNG FEE	Postage Processing Fee 0357914	EA	1	1	0	1.000	1.00

SUB-TOTAL	107.31
DELIVERY	0.00
SALES TAX	0.00
TOTAL	107.31

All amounts are based on USD currency

To return supplies, please repack in original box and insert our packing list, or copy of this invoice. Please note problem so we may issue credit or replacement, whichever you prefer. Please do not ship collect. Please do not return furniture or machines until you call us first for instructions. Shortage or damage must be reported within 5 days after delivery.

DETACH HERE

CUSTOMER NAME	BILLING ID	INVOICE NUMBER	INVOICE DATE	INVOICE AMOUNT	AMOUNT ENCLOSED
EAGLE LANDING GOLF COURSE	21782146	407464053001	17-JAN-25	107.31	

FLO 217821461 4074640530011 00000010731 1 5

Please  
 Send Your  
 Check to:

ODP Business Solutions, LLC  
 PO Box 1413  
 Charlotte NC 28201-1413

Please return this stub with your payment to  
 ensure prompt credit to your account.

Please DO NOT staple or fold. Thank You.

002815-000352



ODP Business Solutions, LLC  
 PO BOX 7241  
 SIOUX FALLS SD  
 57117-7241

ORIGINAL INVOICE

10000

THANKS FOR YOUR ORDER

IF YOU HAVE ANY QUESTIONS  
 OR PROBLEMS. JUST CALL US  
 FOR CUSTOMER SERVICE ORDER: (888) 263-3423  
 FOR ACCOUNT: (800) 721-6592

FEDERAL ID:86-2161688

INVOICE NUMBER	AMOUNT DUE	PAGE NUMBER
407473698001	19.59	Page 1 of 1
INVOICE DATE	TERMS	PAYMENT DUE
16-JAN-25	Net 30	16-FEB-25

BILL TO:

ATTN: ACCTS PAYABLE  
 EAGLE LANDING GOLF COURSE  
 3989 EAGLE LANDING PKWY  
 ORANGE PARK FL 32065-2641

002915-000352

SHIP TO:

EAGLE LANDING GOLF COURSE  
 3989 EAGLE LANDING PKWY  
 ORANGE PARK FL 32065-2641



ACCOUNT NUMBER	PURCHASE ORDER	SHIP TO ID	ORDER NUMBER	ORDER DATE	SHIPPED DATE		
15779562		3989EAGLELANDINGPKWY	407473698001	16-JAN-25	16-JAN-25		
BILLING ID	ACCOUNT MANAGER	RELEASE	ORDERED BY	DESKTOP	COST CENTER		
21782146			JOE HALIFKO				
CATALOG ITEM #/ MANUF CODE	DESCRIPTION/ CUSTOMER ITEM #	U/M	QTY ORD	QTY SHP	QTY B/O	UNIT PRICE	EXTENDED PRICE
558308 77104	FOCUSNOTEPAD,WHITE 558308	PK	1	1	0	19.590	19.59

*SU-7450*  
*[Signature]*  
*1/21/25*

002915-000352

SUB-TOTAL	19.59
DELIVERY	0.00
SALES TAX	0.00
TOTAL	19.59

All amounts are based on USD currency

To return supplies, please repack in original box and insert our packing list, or copy of this invoice. Please note problem so we may issue credit or replacement, whichever you prefer. Please do not ship collect. Please do not return furniture or machines until you call us first for instructions. Shortage or damage must be reported within 5 days after delivery.

▲ DETACH HERE ▲

CUSTOMER NAME	BILLING ID	INVOICE NUMBER	INVOICE DATE	INVOICE AMOUNT	AMOUNT ENCLOSED
EAGLE LANDING GOLF COURSE	21782146	407473698001	16-JAN-25	19.59	

FL0 217821461 4074736980013 00000001959 1 6

Please  
 Send Your  
 Check to:

ODP Business Solutions, LLC  
 PO Box 1413  
 Charlotte NC 28201-1413

Please return this stub with your payment to  
 ensure prompt credit to your account.

Please DO NOT staple or fold. Thank You.



# STERLING CUT GLASS

Sterling Cut Glass  
5020 Olympic Blvd.  
Erlanger, Kentucky 41018  
PH (859) 283-2333  
DUNS: 423-2377

**PLEASE REMIT CHECK PAYMENT TO:**  
**STERLING CUT GLASS**  
**PO BOX 75148**  
**CINCINNATI, OH 45275-0148**

## Invoice

**INVOICE NO.**  
0591648-IN

**DATE**  
10/16/2024

Promotion:

**Sold To:**  
EAGLE LANDING G.C.  
ATTN: JOSHUA HEINTZMAN  
3989 EAGLE LANDING PKWY  
ORANGE PARK, FL 32065

**Ship To:**  
EAGLE LANDING G.C.  
ATTN: GOLF SHOP  
3989 EAGLE LANDING PKWY  
ORANGE PARK, FL 32065

**TERMS DISCOUNTS INCLUDE  
THE SUBTOTAL ONLY, NOT FREIGHT  
OR TAX  
DISCOUNTS ARE FORFEITED IF  
INVOICE IS NOT PAID WITHIN TERMS**

<b>ORDER NO.</b> 0534581	<b>ORDER DATE</b> 9/24/2024	<b>CUSTOMER NO.</b> 01-0320022	<b>SLMS. NO.</b> 0368	<b>CUST. P.O.</b> RECONATION	<b>SHIPPED VIA</b> UPS GROUND	<b>SHIP DATE</b> 10/16/2024	<b>TERMS CODE</b> NET 30
-----------------------------	--------------------------------	-----------------------------------	--------------------------	---------------------------------	----------------------------------	--------------------------------	-----------------------------

QUANTITY		B/O	ITEM NO.	DESCRIPTION	UNIT PRICE	SETCODE	Amount
ORDERED	SHIPPED						
1	1	0	62-002S	VOLTAIRE ART VASE - SM BLUE/TU	100.000	IND	100.00

THANK YOU FOR YOUR SERVICE

7400/100  
EJH  
AS  
1/29/25

**Tracking No.** 1Z45X9550394350511

Our Sales Tax Policy can be viewed at [www.sterlingcutglass.com/salestax](http://www.sterlingcutglass.com/salestax)

**To access your account and pay by credit card, visit [www.sterlingcutglass.com](http://www.sterlingcutglass.com).**  
For first-time online payments, use "Sign In" at the top then "create a new contact."  
Provide your customer number and the billing zip code. Set up a username and password.  
You can access your invoices and make payment from the account portal.  
For any accounting questions, please call 800-543-1317x114.

SUBTOTAL	100.00
FREIGHT	18.69
SALES TAX	0.00

**TOTAL** 118.69  
**(PLEASE PAY THIS AMOUNT)**

All claims for damage or shortages must be reported to Sterling within 10 days of receipt of goods.  
You must save all cartons and packing material in order for your claim to be substantiated.

# STERLING CUT GLASS

Sterling Cut Glass  
5020 Olympic Blvd.  
Erlanger, Kentucky 41018  
PH (859) 283-2333  
DUNS: 423-2377

**PLEASE REMIT CHECK PAYMENT TO:**  
**STERLING CUT GLASS**  
**PO BOX 75148**  
**CINCINNATI, OH 45275-0148**

PAGE 1

## Invoice

**INVOICE NO.**  
0592711-IN

**DATE**  
11/1/2024

Promotion:

**Sold To:**  
EAGLE LANDING G.C.  
ATTN: ERNIE CRUZ  
3989 EAGLE LANDING PKWY  
ORANGE PARK, FL 32065

**Ship To:**  
EAGLE LANDING G.C.  
ATTN: ERNIE CRUZ  
3989 EAGLE LANDING PKWY  
ORANGE PARK, FL 32065

**TERMS DISCOUNTS INCLUDE  
THE SUBTOTAL ONLY, NOT FREIGHT  
OR TAX  
DISCOUNTS ARE FORFEITED IF  
INVOICE IS NOT PAID WITHIN TERMS**

ORDER NO.	ORDER DATE	CUSTOMER NO.	SLMS. NO.	CUST. P.O.	SHIPPED VIA	SHIP DATE	TERMS CODE
0536474	10/24/2024	01-0320022	0368	ADDED FLIGHT	UPS GROUND	11/1/2024	NET 30
QUANTITY		ITEM NO.	DESCRIPTION		UNIT PRICE	SETCODE	Amount
ORDERED	SHIPPED	B/O					
2	2	0	07-044S	GALAXY TROPHY VASE WHITE - SM	85.000	IND	170.00
DEEP ETCH - ADDED FLIGHT							

7400/100  
E.C.

1/29/25

**Tracking No.** 1Z45X9550391048274;

Our Sales Tax Policy can be viewed at [www.sterlingcutglass.com/salestax](http://www.sterlingcutglass.com/salestax)

**To access your account and pay by credit card, visit [www.sterlingcutglass.com](http://www.sterlingcutglass.com).**

For first-time online payments, use "Sign In" at the top then "create a new contact."

Provide your customer number and the billing zip code. Set up a username and password.

You can access your invoices and make payment from the account portal.

For any accounting questions, please call 800-543-1317x114.

SUBTOTAL	170.00
FREIGHT	24.85
SALES TAX	0.00

**TOTAL** 194.85  
**(PLEASE PAY THIS AMOUNT)**

All claims for damage or shortages must be reported to Sterling within 10 days of receipt of goods.  
You must save all cartons and packing material in order for your claim to be substantiated.



CUSTOMER'S ORIGINAL INVOICE CONFIDENTIAL PROPERTY OF SYSCO

EAGLE LANDING GOLF CLUB  
3989 EAGLE LANDING PKWY  
ORANGE PARK FL 32065-2641



SYSCO JACKSONVILLE, INC.  
1501 LEWIS INDUSTRIAL DRIVE  
JACKSONVILLE, FL 32254  
1-800-797-2627 (1-800 SYSCO CS

904-637-0648

EAGLE LANDING GOLF CLUB  
3989 EAGLE LANDING PKWY  
ORANGE PARK FL 32065 -2641

DELV. DATE	CUSTOMER	INVOICE NUMBER	PAGE
1/11/25	784966	583045323	8 3
TRUCK STOP	632/003		
ROUTE	6637	PURCHASE ORDER	
TERMS -PAST DUE BALANCES ARE SUBJECT TO SERVICE CHARGE			
Net 30			
MANIFEST# 1277354 NORMAL DELIVERY			
MA: TVADC SCARLETT BAYLESS			

DRIVER:

QTY	PACK	SIZE	ITEM DESCRIPTION	ITEM CODE	UNIT PRICE	UNIT TAX AMOUNT	EXTENDED PRICE	INVOICE ADJUSTMENTS	
								CODE	QTY
			GROUP TOTAL****				167.60		
MISC CHARGES			ALLOWANCE FOR DROP SIZE				9.14-		
			CHGS FOR FUEL SURCHARGE				6.00		
ORDER SUMMARY			: 2767288 2768277 2768037						

*[Handwritten signature]*  
1/24/25

000  
290-1340=906.52  
100-7450=90.49  
Total=999.01

CASES	SPLIT	TOT. PCS	CUBE	GROSS WT.	OPEN: 7:00 AM	CLOSE: 5:00 PM	REMIT TO	SUB TOTAL
27	3	30	27.1	539			SYSCO JACKSONVILLE 1501 LEWIS INDUSTRIAL DR JACKSONVILLE, FL 32254	1080.86
DRIVER'S SIGN	NO. PCS DELVD.	CUST. SIGN	STIGED INVOICE EVIDENCES OF ALL ITEMS		NO. PCS REC.			TAX TOTAL
		X						INVOICE TOTAL
IMPORTANT FACT PROVISION: THE PERISHABLE AGRICULTURAL COMMODITIES LISTED ON THIS INVOICE ARE SUBJECT TO THE STATUTORY TRUST AUTHORIZED BY SECTION 5 (C) OF THE PERISHABLE AGRICULTURAL COMMODITIES ACT 1930 (U.S.C. 498(C)). THE SELLER OF THIS COMMODITY RETAINS A TRUST CLAIM OVER THESE COMMODITIES. ALL INVENTORIES OF FOOD OR OTHER PRODUCTS DERIVED FROM THESE COMMODITIES AND ANY RECEIVABLES OR PROCEEDS FROM THE SALE OF THESE COMMODITIES UNTIL FULL PAYMENT IS RECEIVED. FURTHER, YOU AGREE WITH RESPECT TO ANY DISPUTE ARISING OUT OF YOUR RECEIPT OF THESE PRODUCTS/SERVICES: YOU ARE GIVING UP YOUR RIGHT TO SERVE IN ANY REPRESENTATIVE CAPACITY, OR TO PARTICIPATE AS A MEMBER OF A CLASS OF CLAIMANTS, IN ANY LAWSUIT INVOLVING ANY SUCH DISPUTE.							PAYABLE ON OR BEFORE	
							2/10/25	LAST PAGE -81.85 999.01

EQUAL OPPORTUNITY AND AFFIRMATIVE ACTION CLAUSES OF 41 CFR 60-1.4, 60-250.4 AND 60-714.4 ARE INCORPORATED HEREIN BY REFERENCE



EAGLE LANDING GOLF CLUB  
3989 EAGLE LANDING PKWY  
ORANGE PARK FL 32065-2641



904-637-0648

EAGLE LANDING GOLF CLUB  
3989 EAGLE LANDING PKWY  
ORANGE PARK FL 32065 -2641

SYSCO JACKSONVILLE, INC.  
1501 LEWIS INDUSTRIAL DRIVE  
JACKSONVILLE. FL 32254  
1-800-797-2627 (1-800 SYSCO CS

CUSTOMER'S ORIGINAL INVOICE CONFIDENTIAL PROPERTY OF SYSCO

DELIV. DATE	CUSTOMER	INVOICE NUMBER	PAGE
1/11/25			
TRUCK STOP	784966	583045323	8 1
632 /003			
ROUTE	PURCHASE ORDER		
6637	TERMS -PAST DUE BALANCES ARE SUBJECT TO SERVICE CHARGE		
	Net 30		
	MANIFEST# 1277354 NORMAL DELIVERY		
	MA: TVADC SCARLETT BAYLESS		

DRIVER:

QTY	PACK	SIZE	ITEM DESCRIPTION	ITEM CODE	UNIT PRICE	UNIT TAX AMOUNT	EXTENDED PRICE	TAX	INVOICE ADJUSTMENTS	
								CODE	QTY	
FOOD SAFETY REMINDER: NOTHING IS MORE IMPORTANT TO SYSCO THAN DELIVERING SAFE PRODUCTS. PLEASE VERIFY EACH ORDER UPON RECEIPT BECAUSE COOLER ITEMS CANNOT BE RETURNED LATER.										
SALTWATER FISH LIC WD-4511 FRESHWATER FISH LIC FWD-803 SHELLFISH CERT NUMBER 182 SS										
***DAIRY***										
C	1 CS	81.5 LB	LEBR LIMP CHEESE CHDR MLD SLI INT .75 Y 170748	3546369	38.48		38.48			
C	1 SCS	45 LB	CASAMP CHEESE CHEDDAR JACK FNCY SHRE 2905C4	2406189	60.02		60.02			
C	1 CS	81.5 LB	LEBR LIMP CHEESE SWISS SLICE .75 OZ 170721	3554569	57.47		57.47			
GROUP TOTAL****								155.97		
***MEATS***										
F	1 CS	325 OZ	CAB BEEF STEAK PHILLY CAB BR 10000001650	9789785	81.85		81.85			
F	1 CS	962 OZ	SYS IMP SAUSAGE PATTY W/H WIDE RAW MLD 19741	3756236	32.91		32.91			
GROUP TOTAL****								114.76		
***FROZEN***										
F	1 CS	243.25OZ	CHFPIER DANISH ASST IW 08349	1086313	24.31		24.31			
F	OUT CS	14.75LB	BRKLYN DESSERT TIRAMISU PRECUT CAKE TC14	2973622						
OUT/STOCK 1										
F	1 CS	24.25LB	BRKLYN DESSERT TIRAMISU PAN 30 PC SCR TIT	7105897	45.93		45.93			
SUBSTITUTE										
F	1 CS	722 OZ	BURRY MUFFIN ENGLISH PLAIN FKSPLT 30001	3523463	21.98		21.98			
F	1 CS	82LB	TANTLZR ONION RING BRD GOURM 5/8IN 30410	0916387	57.07		57.07			
F	1 CS	2012 IN	AREZCLS PIZZA CRUST PRK RSD ED T 025460-0071	6400097	20.05		20.05			
F	2 CS	65 LB	LAMCOD POTATO FRY CRSPY CT CONCERTINA LW202	7135105	56.10		112.20			
F	1 CS	62.5 LB	MCCAIN POTATO FRY SWEET 5/16 MCF03731	3700499	31.08		31.08			

*long 7.00*

CASES	SPLIT	TOT. PCS	CUBE	GROSS WT.	OPEN: 7:00 AM	CLOSE: 5:00 PM	REMIT TO
13		13	9.8	207			SYSCO JACKSONVILLE 1501 LEWIS INDUSTRIAL DR JACKSONVILLE, FL 32254
							SHR TOTAL 583.35
DRIVER'S SIGN							TAX TOTAL
NO. PCS DELVD.							INVOICE TOTAL
CUST. SIGNED INVOICE EVIDENCE OF ALL ITEMS SIGN X							
NO. PCS REC.							

IMPORTANT NOTICE: THE PERISHABLE AGRICULTURAL COMMODITIES LISTED ON THIS INVOICE ARE SUBJECT TO THE STATUTORY TRUST AUTHORIZED BY SECTION 5 (C) OF THE PERISHABLE AGRICULTURAL COMMODITIES ACT 1930 (U.S.C. 495E(C)). THE SELLER OF THIS COMMODITY RETAINS A TRUST CLAIM OVER THESE COMMODITIES. ALL INVENTORIES OF FOOD OR OTHER PRODUCTS DERIVED FROM THESE COMMODITIES AND ANY RECEIVABLES OR PROCEEDS FROM THE SALE OF THESE COMMODITIES UNTIL FULL PAYMENT IS RECEIVED. FURTHER, YOU AGREE WITH RESPECT TO ANY DISPUTE ARISING OUT OF YOUR RECEIPT OF THESE PRODUCTS/SERVICES: YOU ARE GIVING UP YOUR RIGHT TO SERVE IN ANY REPRESENTATIVE CAPACITY OR TO PARTICIPATE AS A MEMBER OF A CLASS OF CLAIMANTS, IN ANY LAWSUIT INVOLVING ANY SUCH DISPUTE.

PAYABLE ON OR BEFORE  
CONT. ON PAGE 2

LEGAL OPPORTUNITY AND AFFIRMATIVE ACTION CLAUSES OF 41 CFR 60-1.4, 60-250.4 AND 60-714.4 ARE INCORPORATED HEREIN BY REFERENCE



EAGLE LANDING GOLF CLUB  
3989 EAGLE LANDING PKWY  
ORANGE PARK FL 32065-2641



SYSCO JACKSONVILLE, INC.  
1501 LEWIS INDUSTRIAL DRIVE  
JACKSONVILLE, FL 32254  
1-800-797-2627 (1-800 SYSCO CS)

904-637-0648

EAGLE LANDING GOLF CLUB  
3989 EAGLE LANDING PKWY  
ORANGE PARK FL 32065 -2641

CUSTOMER'S ORIGINAL INVOICE CONFIDENTIAL PROPERTY OF SYSCO

DELV. DATE	CUSTOMER	INVOICE NUMBER	PAGE
1/11/25	784966	583045323	8 2
TRUCK STOP	632/003		
ROUTE	6637		
PURCHASE ORDER			
TERMS -PAST DUE BALANCES ARE SUBJECT TO SERVICE CHARGE			
Net 30			
MANIFEST# 1277354 NORMAL DELIVERY			
MA: TVADC SCARLETT BAYLESS			

DRIVER:

UNIT	QTY	PACK	SIZE	ITEM DESCRIPTION	ITEM CODE	UNIT PRICE	UNIT TAX AMOUNT	EXTENDED PRICE	INVOICE ADJUSTMENTS	
									CODE	QTY
GROUP TOTAL****								312.62		
***CANNED & DRY***										
D	1	CS	1232 OZ	OCNSPRY JUICE CRNBRY BTL BAR MIXER 25900	5099122	24.47		24.47		
C	1	CS	859 OZ	TROPCNA JUICE ORANGE PURE PRE 10048500201029	8410563	34.03		34.03		
D	1	CS	1211.50Z	HELLMAN MAYONNAISE SQUEEZE BT 00000084137049	3420587	53.75		53.75		
D	1S	ONLY1	GAL	SYS CLS VINEGAR DISTILLED WHITE 5% 911123	4113049	5.27		5.27		
D	2	CS	4016.9OZ	NIAGARA WATER BOTTLED SPRING	9901031	13.73		27.46		
D	1	CS	612 CT	TAC MEX WRAP TORTILLA GRCL HERB 12 195210	8031852	23.16		23.16		
GROUP TOTAL****								168.14		
***PAPER & DISP***										
D	1	CS	1509X9X3	SYS CLS CONTAINER FOAM HNG 1C D YTD199S10000	7551334	21.16		21.16		
D	1	CS	2025 CT	DART CUP FOAM TALL 20 OZ 20J16	4088886	27.56		27.56		
D	1	CS	10060 GAL	SYS REL LINER REPRO 38X58 1.5 ML X7658AKSX01	1763846	41.77		41.77		
GROUP TOTAL****								90.49		
***PRODUCE***										
C	1	CS	112 CT	IMPFRSH AVOCADO HASS FRESH	1185511	29.60		29.60		
C	1	CS	112 CT	IMPFRSH LIME FRESH	7412570	11.39		11.39		
C	1S	ONLY1	10 LB	IMPFRSH ONION YELLOW JUMBO FRESH SACK	7201992	9.07		9.07		
C	1S	ONLY1	16 OZ	DRISCOL STRAWBERRY FRESH DRISCOLL	7582505	5.03		5.03		
C	1	CS	110 LB	IMPFRSH TOMATO 1 LAYER 5X6	1008630	19.33		19.33		
GROUP TOTAL****								74.42		
***DISPENSER BEVERAGE***										
D	1	CS	15 GAL	COCACOL SYRUP COKE ZERO SUGAR 5X1 B 37150010	5006448	110.15		110.15		
D	1	CS	12.5GAL	SEAGRAM SYRUP GINGER ALE 5X1 BIB 52400298	1978586	57.45		57.45		

CASES	SPLIT	TOT. PCS	CUBE	GROSS WT.	OPEN: 7:00 AM	CLOSE: 5:00 PM	REMIT TO
14	3	17	17.3	332			SYSCO JACKSONVILLE 1501 LEWIS INDUSTRIAL DR JACKSONVILLE, FL 32254
DRIVER'S SIGN							TAX TOTAL
NO. PCS DELVD.							INVOICE TOTAL
CUST. SIGNED INVOICE EVIDENCE OF ALL ITEMS SIGN X							1084.00
NO. PCS REC.							TOTAL

IMPORTANT PACT PROVISION: THE PERISHABLE AGRICULTURAL COMMODITIES LISTED ON THIS INVOICE ARE SUBJECT TO THE STATUTORY TRUST AUTHORIZED BY SECTION 5 (C) OF THE PERISHABLE AGRICULTURAL COMMODITIES ACT 1930 (U.S.C. 499E(C)). THE SELLER OF THIS COMMODITY RETAINS A TRUST CLAIM OVER THESE COMMODITIES, ALL INVENTORIES OF FOOD OR OTHER PRODUCTS DERIVED FROM THESE COMMODITIES, AND ANY RECEIVABLES OR PROCEEDS FROM THE SALE OF THESE COMMODITIES UNTIL FULL PAYMENT IS RECEIVED. FURTHER, YOU AGREE WITH RESPECT TO ANY DISPUTE ARISING OUT OF YOUR RECEIPT OF THESE PRODUCTS/SERVICES: YOU ARE GIVING UP YOUR RIGHT TO SERVE IN ANY REPRESENTATIVE CAPACITY, OR TO PARTICIPATE AS A MEMBER OF A CLASS OF CLAIMANTS, IN ANY LITIGATION INVOLVING ANY SUCH DISPUTE.

PAYABLE ON OR BEFORE

CONT. ON PAGE 3

EQUAL OPPORTUNITY AND AFFIRMATIVE ACTION CLAUSES OF 41 CFR 60.1.4, 60-250.4 AND 60-714.4 ARE INCORPORATED HEREIN BY REFERENCE



EAGLE LANDING GOLF CLUB  
3989 EAGLE LANDING PKWY  
ORANGE PARK FL 32065-2641

904-637-0648

EAGLE LANDING GOLF CLUB  
3989 EAGLE LANDING PKWY  
ORANGE PARK FL 32065 -2641



SYSCO JACKSONVILLE, INC.  
1501 LEWIS INDUSTRIAL DRIVE  
JACKSONVILLE, FL 32254  
1-800-797-2627 (1-800 SYSCO CS

CUSTOMER'S ORIGINAL INVOICE CONFIDENTIAL PROPERTY OF SYSCO

DELV. DATE	CUSTOMER	INVOICE NUMBER	PAGE
1/15/25	784966	583049266	5 2
TRUCK STOP	351 /011		
ROUTE	3612		
PURCHASE ORDER			
TERMS -PAST DUE BALANCES ARE SUBJECT TO SERVICE CHARGE			
Net 30			
MANIFEST# 1277726 NORMAL DELIVERY			
MA: TVADC SCARLETT BAYLESS			

DRIVER: TEMPLETON

QTY	PACK	SIZE	ITEM DESCRIPTION	ITEM CODE	UNIT PRICE	EXTENDED PRICE	TAX AMOUNT	T	P	INVOICE ADJUSTMENTS	
										CODE	QTY
1S	ONLY1 GAL		SYS IMP OIL OLIVE X-VRGIN DELCATO 10 4497301	4497301	68.31	68.31					
2S	ONLY1 GAL		CASACLS PEPPER JALAPENO SLICES 12730720211	8426330	12.17	24.34					
1 CS	104 LB		SYS CLS SUGAR GRANULATED XFINE CANE 412006	2926727	41.79	41.79					
2 CS	4016.9OZ		NIAGARA WATER BOTTLED SPRING GROUP TOTAL****	9901031	13.73	27.46					
			***PAPER & DISP***			222.22					
2 CS	1509X9X3		SYS CLS CONTAINER FOAM HNG 1C D YTD199S10000	7551334	21.16	42.32					
1 CS	2025 CT		DART CUP FOAM TALL 20 OZ 20J16	4088886	27.56	27.56					
1 CS	10100CT		DART LID PLAS STRAW SLOT 12-24OZ 16SL	4096327	18.90	18.90					
1 CS	10060 GAL		SYS REL LINER REPRO 38X58 1.5 ML X7658AKSX01	1763846	41.77	41.77					
1 CS	16250CT		SYS CLS TOWEL MULTIFOLD 9.4X9.2 WHT 4458693	4458693	42.69	42.69					
			GROUP TOTAL****			173.24					
			***PRODUCE***								
1S	ONLY5 LB		IMPFRSH APPLE RED DEL X-FANCY 85WAXFCYREDEL	7198253	9.70	9.70					
1S	ONLY6 CT		SYFPNAT LETTUCE ICEBERG TRIMMED FRESH	1675610	9.95	9.95					
1S	ONLY10 LB		IMPFRSH ONION YELLOW JUMBO FRESH SACK	7201992	9.06	9.06					
2S	ONLY5 LB		IMPFRSH ORANGE BAGGED FRESH 10889356163020	7289526	9.42	18.84					
2S	ONLY16 OZ		DRISCOL STRAWBERRY FRESH DRISCOLL	7582505	5.05	10.10					
1 CS	110 LB		IMPFRSH TOMATO 1 LAYER 5X6	1008630	19.33	19.33					
			GROUP TOTAL****			76.98					
MISC CHARGES			ALLOWANCE FOR DROP SIZE			8.92-					
			CHGS FOR FUEL SURCHARGE			8.00					
ORDER SUMMARY			: 2770497								

000  
240-1340 = 75.61  
240-7450 = 173.24  
Total = 888.85

CASES	SPLIT	TOT. PCS	CUBE	GROSS WT.	OPEN: 7:00 AM	CLOSE: 5:00 PM	REMIT TO	
10	10	20	19.0	282	SYSCO JACKSONVILLE 1501 LEWIS INDUSTRIAL DR JACKSONVILLE, FL 32254			SUB TOTAL 888.85
19	13	32	26.4	463				TAX TOTAL
DRIVER'S SIGN		NO. PCS DELVD.	CUST. SIGNED INVOICE SIGN	NO. PCS REC.	PAYABLE ON OR BEFORE			INVOICE TOTAL 888.85
IMPORTANT FACA PROVISION: THE PERISHABLE AGRICULTURAL COMMODITIES LISTED ON THIS INVOICE ARE SUBJECT TO THE STATUTORY TRUST AUTHORIZED BY SECTION 5 (C) OF THE PERISHABLE AGRICULTURAL COMMODITIES ACT 1930 (U.S.C. 499E(C)). THE SELLER OF THIS COMMODITY RETAINS A TRUST CLAIM OVER THESE COMMODITIES, ALL INVENTORIES OF FOOD OR OTHER PRODUCTS DERIVED FROM THESE COMMODITIES, AND ANY RECEIVABLES OR PROCEEDS FROM THE SALE OF THESE COMMODITIES UNTIL FULL PAYMENT IS RECEIVED. FURTHER, YOU AGREE WITH RESPECT TO ANY DISPUTE ARISING OUT OF YOUR RECEIPT OF THESE PRODUCTS/SERVICES: YOU ARE GIVING UP YOUR RIGHT TO SERVE IN ANY REPRESENTATIVE CAPACITY, OR TO PARTICIPATE AS A MEMBER OF A CLASS OF CLAIMANTS, IN ANY LAWSUIT INVOLVING ANY SUCH DISPUTE.							2/14/25	LAST PAGE

EQUAL OPPORTUNITY AND AFFIRMATIVE ACTION CLAUSES OF 41 CFR 60-1.6, 60-250.4 AND 60-714.4 ARE INCORPORATED HEREIN BY REFERENCE





CUSTOMER'S ORIGINAL INVOICE CONFIDENTIAL PROPERTY OF SYSCO

EAGLE LANDING GOLF CLUB  
3989 EAGLE LANDING PKWY  
ORANGE PARK FL 32065-2641



SYSCO JACKSONVILLE, INC.  
1501 LEWIS INDUSTRIAL DRIVE  
JACKSONVILLE, FL 32254  
1-800-797-2627 (1-800 SYSCO CS

904-637-0648

EAGLE LANDING GOLF CLUB  
3989 EAGLE LANDING PKWY  
ORANGE PARK FL 32065 -2641

DELV. DATE	CUSTOMER	INVOICE NUMBER	PAGE
1/15/25	784966	583049266	5 1
TRUCK STOP	PURCHASE ORDER		
351/011	TERMS -PAST DUE BALANCES ARE SUBJECT TO SERVICE CHARGE		
ROUTE	Net 30		
3612	MANIFEST# 1277726 NORMAL DELIVERY		
	MA: TVADC SCARLETT BAYLESS		

DRIVER: TEMPLETON

QTY	PACK	SIZE	ITEM DESCRIPTION	ITEM CODE	UNIT PRICE	UNIT TAX AMOUNT	EXTENDED PRICE	TOT	INVOICE ADJUSTMENTS
FOOD SAFETY REMINDER: NOTHING IS MORE IMPORTANT TO SYSCO THAN DELIVERING SAFE PRODUCTS. PLEASE VERIFY EACH ORDER UPON RECEIPT BECAUSE COOLER ITEMS CANNOT BE RETURNED LATER. SALTWATER FISH LIC WD-4511 FRESHWATER FISH LIC FWD-803 SHELLFISH CERT NUMBER 182 SS									
***DAIRY***									
C	1S	ONLY5 LB	BBRLCLS CHEESE AMER 120 SLI YEL	STK14207	5132234	16.38	16.38		
C	1SCS	45 LB	CASAIMP CHEESE CHEDDAR JACK FNCY SHRE	2905C4	2406189	60.31	60.31		
C	1 CS	81.5 LB	BBRLIMP CHEESE PROV NONSMK SLI .75	170754	3546386	44.52	44.52		
C	1 CS	41 GAL	WHLFCLS MILK WHL GALLON		4676306	23.38	23.38		
GROUP TOTAL****							144.59		
***MEATS***									
F	1 CS	325 OZ	CAB BEEF STEAK PHILLY CAB BR	10000001650	9789785	81.85	81.85		
GROUP TOTAL****							81.85		
***SEAFOOD***									
F	1 CS	42.5 LB	PORTCLS SHRIMP WHT P&D TLOF 16/2	261512071PB	5106388	65.85	65.85		
GROUP TOTAL****							65.85		
***FROZEN***									
F	1 CS	82LB	TANTLZR ONION RING BRD GOURM 5/8IN	30410	0916387	57.07	57.07		
F	1 CS	62.5 LB	MCCAIN POTATO FRY SWEET 5/16	MCF03731	3700499	31.08	31.08		
F	1 CS	722.4 OZ	BAV BAK PRETZEL BAVARIAN STK	3295	6849145	38.89	38.89		
GROUP TOTAL****							127.04		
***CANNED & DRY***									
D	1S	ONLY.5GAL	SYS IMP CHERRY MARA STEM LG PLAS	10111158	5083944	22.76	22.76		
C	1S	ONLY1 GAL	KENS DRESSING BALSAMIC VINEGARETTE	KE0955	7872328	16.98	16.98		
D	1 CS	2410 OZ	TROPANA JUICE APPLE PET	00048500757178	1605617	20.58	20.58		

CASES	SPLIT	TOT. PCS	CUBE	GROSS WT.	OPEN: 7:00 AM	CLOSE: 5:00 PM	REMIT TO		
9	3	12	7.4	181			SYSCO JACKSONVILLE 1501 LEWIS INDUSTRIAL DR. JACKSONVILLE, FL 32254	SHB TOTAL 479.65	
DRIVER'S SIGN							NO. PCS DELVD.	CUST. SIGNED INVOICE EVIDENCE OF ALL ITEMS SIGN X	NO. PCS REC.
TAX TOTAL							INVOICE TOTAL		
IMPORTANT FACA PROVISION: THE PERISHABLE AGRICULTURAL COMMODITIES LISTED ON THIS INVOICE ARE SUBJECT TO THE STATUTORY TRUST AUTHORIZED BY SECTION 5 (C) OF THE PERISHABLE AGRICULTURAL COMMODITIES ACT 1930 (U.S.C. 495E(C)). THE SELLER OF THIS COMMODITY RETAINS A TRUST CLAIM OVER THESE COMMODITIES. ALL INVENTORIES OF FOOD OR OTHER PRODUCTS DERIVED FROM THESE COMMODITIES, AND ANY RECEIVABLES OR PROCEEDS FROM THE SALE OF THESE COMMODITIES UNTIL FULL PAYMENT IS RECEIVED. FURTHER, YOU AGREE WITH RESPECT TO ANY DISPUTE ARISING OUT OF YOUR RECEIPT OF THESE PRODUCTS/SERVICES: YOU ARE GIVING UP YOUR RIGHT TO SERVE IN ANY REPRESENTATIVE CAPACITY, OR TO PARTICIPATE AS A MEMBER OF A CLASS OF CLAIMANTS, IN ANY LAWSUIT INVOLVING ANY SUCH DISPUTE.							PAYABLE ON OR BEFORE		
							CONT. ON PAGE 2		

EQUAL OPPORTUNITY AND AFFIRMATIVE ACTION CLAUSES OF 41 CFR 60-1.4, 60-250.4 AND 60-719.4 ARE INCORPORATED HEREIN BY REFERENCE



# Invoice

TableTop Linen Rental  
 898 Bellevue Ave.  
 support@tabletoplinen.com  
 Daytona Beach, FL 32114 (386)254-3158

EAGLE LANDING GOLF CLUB  
 3989 Eagle Landing Parkway  
 Orange Park, FL 32065 (904)860-7177

Date	Invoice	Day	Garment Mark	Freq.	Seq	Term	Account	Route
01/22/2025	0136109	Wed		7	30	CHG	1193-00000	7

Line	Item	Empl	Name / Description	Sizes	Qty.	Min.	Adj. Qty.	Adj. Amt.	Unit Pr.	Ext. Price	OFFICE		ROUTE		Total
											Adj. Qty.	Adj. Amt.	Adj. Qty.	Adj. Amt.	
1	FBNPW		NAPKIN WHITE		200	0	0	\$0.00	\$0.1320	\$26.40	0	0	\$0.00	\$0.00	\$26.40
2	FBNPW		NAPKIN WHITE		SRC	0	0	\$0.00	\$2.0000	\$4.00	0	0	\$0.00	\$0.00	\$4.00
3	DGBAGST		BAG STAND			0	0	\$0.00	\$0.1000	\$0.20	0	0	\$0.00	\$0.00	\$0.20
4	FB8585W		TC 85X85 WHITE		90	0	0	\$0.00	\$1.7600	\$158.40	0	0	\$0.00	\$0.00	\$158.40
5	FBMESBAG		MESH BAG		10	0	0	\$0.00	\$0.1000	\$1.00	0	0	\$0.00	\$0.00	\$1.00
6	DGCARTHAM		CART HAMPER			0	0	\$0.00	\$5.0000	\$10.00	0	0	\$0.00	\$0.00	\$10.00
7	TPP		TOTAL PROTECTION PLAN					\$0.00		\$9.80			\$0.00	\$0.00	\$9.80
			Delivery Charge					\$0.00		\$15.70			\$0.00	\$0.00	\$15.70

Total Due	Cur. Bus.	Cur. Bal.	30	60	90	120	Office Adj.:	\$0.00	Subtotal:	\$225.50	Rte. Adj.:	\$0.00
\$419.18	\$225.50	\$0.00	\$193.68	\$0.00	\$0.00	\$0.00	Tax Adj.:	\$0.00	Sales Tax:	\$0.00	Tax Adj.:	\$0.00
Comment:							Net Adj.:	\$0.00	Prebill:	\$225.50	Net Adj.:	\$0.00

Total Adj.: \$0.00  
 Tax Adj.: \$0.00

Net Charge: **\$225.50**

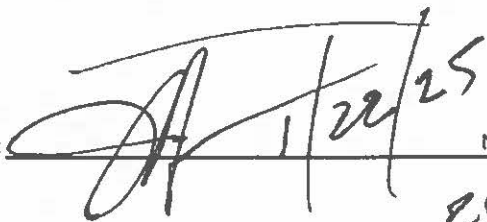
Received By:  01/22/25  
 N 01/22/2025 3:18:01PM

240-7465 Linen  
 \$225.50

  
 1/22/25



7600-500

INVOICE DATE	INVOICE NUMBER
JAN 15, 2025	155462-8

**PLEASE REMIT TO:**  
 TWC Services, Inc.  
 PO Box 14496  
 Des Moines, IA 50306-3496  
 Phone: 904-899-0220  
**TERMS: Net 30 Days**

**BILL TO:**

Eagle Landing Golf Club  
 3989 Eagle Landing Parkway  
 Orange Park FL 32065

276829

DETAIL	AMOUNT
<b>Maintenance Contract 155462</b> <b>Eagle Landing Golf</b>  Eagle Landing Golf Club 3989 Eagle Landing Parkway Orange Park, FL 32065  Billing Period: 01/01/2025 – 06/30/2025 Planned Maintenance Billing per Contract Email to: jhalifko@troon.com	<div style="text-align: right;"> <p>793.33</p> <hr/> <p>Subtotal 793.33</p> <p>Tax <del>59.50</del></p> <p><b>Total Amount Due 852.83</b></p> </div>
<p>Fee if payment is received after 30 days</p> <p><b>Total Amount Due--If Paid After 02/14/2025</b></p>	<div style="text-align: right;"> <p>47.60</p> <hr/> <p>900.43</p> </div>

*Handwritten:* PAID THIS AMOUNT \$793.33

*Handwritten:* 1/22/25

*Handwritten:* Tax exempt 2/3 term sent TMR NOW PAID

*Handwritten:* Less Tax (59.50)

ACCOUNT INVOICE INVOICE CUSTOMER PURCHASE ORDER  
 NO. NO. DATE NO. NUMBER  
 91221150 2699904 01/24/25 11221140

SALES SALES DATE  
 LOC. REP. ORDERED  
 3055 0832 01/23/25

Route: 5215 / 7

ORDER NUMBER: 69065

Bill To: 50 VILLAGE COMM DEV DISTR  
 3989 EAGLE LANDING PKWY  
 ORANGE PARK FL  
 32065  
 Att: CHRIS COLLETTI

Ship To: TRN EAGLE LANDING GLF CLB  
 3989 EAGLE LANDING PKWY  
 ORANGE PARK FL  
 32065  
 904 291 5600  
 DEPT # 00

Remit To: US Foods, Inc.  
 P.O. BOX 198421  
 ATLANTA GA  
 30384-8421  
 386 763 1304

igFrom: 5425 S. WILLIAMSON BLVD PORT ORANGE FL

ShipD: 01/24/25

Page 02 of 04

Special Instr: DRIVER MUST LEAVE FINAL RECEIPT FOR INV CHANGES

Qty	Sales	Product	Description	Pack Size	Label	C	Weight	Pricing Unit	Unit Price	Extended Price
-----	-------	---------	-------------	-----------	-------	---	--------	--------------	------------	----------------

STORAGE LOCATION RECAP(N)

TOTAL DRY	PIECES ORDERED:	17	PIECES SHIPPED:	17	ITEMS SHIPPED:	15	441.48
TOTAL REFRIGERATED	PIECES ORDERED:	12	PIECES SHIPPED:	12	ITEMS SHIPPED:	10	592.70
TOTAL FROZEN	PIECES ORDERED:	9	PIECES SHIPPED:	8	ITEMS SHIPPED:	4	432.01

TOTAL NET WGT:	709.33	*** INVOICE SUMMARY ***	PIECES ORDERED:	38	PIECES SHIPPED:	37	ITEMS SHIPPED:	29
TOTAL GROSS WGT:	754.92							

PRODUCT TOTAL \$ 1466.19

\*\*\*\*\*  
 \* Federal Occupation Safety and Health Standards, Section 1910.1200 on Hazard \*  
 \* Communication requires manufacturers and distributors to provide Material \*  
 \* Safety Data Sheets on non-food products defined to be hazardous. Products \*  
 \* such as cleaning products and pesticides are included in the scope of the \*  
 \* Standard. In compliance with the law, MSDS are available to US Foods, Inc. \*  
 \* customers and can be obtained by contacting the Procurement Manager in our \*  
 \* district office or by advising your sales representative. \*  
 \* You may contact HAZMAT HOTLINE at phone # (800) 424 - 8802. \*  
 \*\*\*\*\*

TAXABLE AMOUNT \$ .00  
 GEN SALES TAX % 00

This amount is an estimate at time of shipping prior to any adjustments made at delivery: \$ 1466.19

*Handwritten signature and initials*

000  
~~240-1340~~ = 1341.52  
 100-7450 = 124.67  
 Total = 1466.19

ACCOUNT INVOICE INVOICE CUSTOMER PURCHASE ORDER  
 NO. NO. DATE NO. NUMBER  
 91221150 2699904 01/24/25 11221140

SALES SALES DATE  
 LOC. REP. ORDERED  
 3055 0832 01/23/25

Route: 5215 / 7

ORDER NUMBER: 69065

Bill

To: SO VILLAGE COMM DEV DISTR  
 3989 EAGLE LANDING PKWY  
 ORANGE PARK FL  
 32065  
 Att: CHRIS COLLETTI

Ship

To: TRN EAGLE LANDING GLF CLB  
 3989 EAGLE LANDING PKWY  
 ORANGE PARK FL  
 32065  
 904 291 5600  
 DEPT # 00

Remit

To: US Foods, Inc.  
 P.O. BOX 198421  
 ATLANTA GA  
 30384-8421  
 386 763 1304

ipFrm: 5425 S. WILLIAMSON BLVD PORT ORANGE FL ShipD: 01/24/25 Page 01 of 04  
 tTrms: DRIVER MUST LEAVE FINAL RECEIPT FOR INV CHANGES  
 tTrms: NET 21 DAYS

Qty	Sales	Product	Description	Pack Size	Label	C	Weight	Pricing	Unit	Extended
Shipped	Unit	Number				D		Unit	Price	Price

1	1	CS	0698688	DRY	OIL, BUTR ALTRN SOYBN SALTD	3/1 GA	MONARCH		CS	33.8900	\$ 33.89
1	1	CS	0719427		LID, CUP 12-20 Z PLST WHT SLOT10/100 EA		MONOGRAM		CS	27.3900	27.39
1	1	CS	0760785		SPICE, PPR BLK GRND JUG REST	5 LB	MONARCH		CS	53.6000	53.60
1	1	EA	1023134		SPICE, CUMIN GRND SHLF STABL	14 OZ	MCCORMICK		EA	12.4300	12.43
1	1	CS	1306853		MUSTARD, YLW SQZ KTL SHLF	12/12 OZ	FRENCH'S		CS	14.3300	14.33
2	2	CS	1328699		SHORTENING, FRYG SOYBN LIQ CLR35 LB		HARVEST VL		CS	31.4900	62.98
1	1	CS	3554565		DRINK, SODA COLA COKE CLSC CAN24/12 OZ		COKE		CS	19.6200	19.62
1	1	CS	3554649		DRINK, SODA DIET COKE ZERO	24/12 OZ	COKE ZERO		CS	18.2900	18.29
1	1	EA	4353462		SEASONING, TACO NO MSG SHLF	21 OZ	MONARCH		EA	7.7300	7.73
2	2	CS	5651351		GLOVE, VINYL XL PF CLR AMBX	10/100 EA	VALUGARDS		CS	21.6700	43.34
1	1	CS	6056492		TORTILLA, FLOUR 6" PRSSD SHLF	12/24 EA	LA BNDRITA		CS	21.7000	21.70
1	1	CS	6733182		CEREAL, OTML ASST INST SS	64 EA	QUAKER		CS	22.8700	22.87
1	1	CS	7802523		NAPKIN, DNMR WHT 17X17 1 PLY	20/250 EA	VALU PLUS		CS	53.9400	53.94
1	1	CS	9009218		RELISH, PKL SWT SS POUCH	200/9 GR	HEINZ		CS	10.5600	10.56
1	1	CS	9837683		SAUCE, GRCL PARM PLST JAR SHLF4/.5 GA		SWEET BABY		CS	38.8100	38.81
REFRIGERATED											
1	1	CS	2326411		LETTUCE, ICBRG FRESH REF BOX	24 EA	CROSS VALY		CS	28.5100	28.51
1	1	EA	2348936		CARROT, STICK 3 3/4" FRESH	5 LB	CROSS VALY	B	EA	8.9400	8.94
READY TO EAT - Please Refer to Return Policy											
3	3	CS	2721173		CHICKEN, WING 1&2JT JMB RAW	4/10 LB	PATUXENT		CS	95.2200	285.66
1	1	CS	2725711		CHICKEN, BRST SNGL 6 Z BNLS	4/5 LB	PATUXENT		CS	68.1100	68.11
1	1	EA	3067402		CANDY, KIT KAT TFF VNOG STD	36 EA	KIT KAT	B	EA	37.7200	37.72
1	1	CS	3331998		BROCCOLI, FLORT MINI ICELS REF4/3 LB		CROSS VALY		CS	31.0100	31.01
READY TO EAT - Please Refer to Return Policy											
1	1	CS	4284530		PEPPER, BELL RED CHD FRESH REFS LB		PACKER		CS	16.0100	16.01
1	1	CS	5327275		BEEF, PTY GRND 80/20 2:1 RND	20/8 OZ	CTLMN SLCT		CS	43.2100	43.21
1	1	CS	8350258		MILK, WHL PSTRD RBST FREE D	4/1 GA	GLNW FRMS		CS	27.4500	27.45
1	1	CS	9124520		DRESSING, RANCH HMSTY PLST JAR4/1 GA		KEN'S		CS	46.0800	46.08
READY TO EAT - Please Refer to Return Policy											
FROZEN											
4	4	CS	2883130		POTATO, FF SC 3/8" EXTRA CRSPY6/5 LB		MONARCH		CS	50.1300	200.52
2	2	CS	7637713		CHICKEN, TMDLN BTRD FRTR BEER2/5 LB		PATUXENT		CS	39.9600	79.92
1	1	CS	8332538		APPETIZER, BROCC CHS CHEDR BTRD6/2 LB		MOLLYS KIT		CS	66.5700	66.57
1	1	CS	9205147		BEEF, PTY GRND 75/25 3:1 HMSTY60/5.33 OZ		TNTISTYDND		CS	85.0000	85.00
1	0	CS	9643842		POTATO, AU GRTN BKD TRAY FZN	60/4 OZ	KABOBS				

ACCOUNT INVOICE INVOICE CUSTOMER PURCHASE ORDER  
 NO. NO. DATE NO. NUMBER  
 91221150 2699905 01/24/25 11221140

SALES SALES DATE  
 LOC. REP. ORDERED  
 3055 0832 01/23/25

Route: 5215 / 7

ORDER NUMBER: 69185

Bill

To: SO VILLAGE COMM DEV DISTR  
 3989 EAGLE LANDING PKWY  
 ORANGE PARK FL  
 32065  
 Att: CHRIS COLLETTI

Ship

To: TRN EAGLE LANDING GLF CLB  
 3989 EAGLE LANDING PKWY  
 ORANGE PARK FL  
 32065  
 904 291 5600  
 DEPT # 00

Remit

To: US Foods, Inc.  
 P.O. BOX 198421  
 ATLANTA GA  
 30384-8421  
 386 763 1304

igFrm: 5425 S. WILLIAMSON BLVD PORT ORANGE FL

ShipD: 01/24/25

Page 01 of 03

tTrms: DRIVER MUST LEAVE FINAL RECEIPT FOR INV CHANGES

tTrms: NET 21 DAYS

Qty	Sales	Product	Description	Pack Size	Label	C	Weight	Pricing Unit	Unit Price	Extended Price
-----	-------	---------	-------------	-----------	-------	---	--------	--------------	------------	----------------

1	1	CS 8116271	FROZEN SOUP, GUMBO CHIX SSG PHO-FREE 3/4 LB		HOLLYS KIT			CS	47.6700	\$ 47.67
---	---	------------	---	--	------------	--	--	----	---------	----------

STORAGE LOCATION RECAP(N)

TOTAL FROZEN	PIECES ORDERED:	1	PIECES SHIPPED:	1	ITEMS SHIPPED:	1	47.67
--------------	-----------------	---	-----------------	---	----------------	---	-------

TOTAL NET WGT:	12.00	*** INVOICE SUMMARY ***	PIECES ORDERED:	1	PIECES SHIPPED:	1	ITEMS SHIPPED:	1
TOTAL GROSS WGT:	12.99							

\*\*\*\*\*  
 \* Federal Occupation Safety and Health Standards. Section 1910.1200 on Hazard \*  
 \* Communication requires manufacturers and distributors to provide Material \*  
 \* Safety Data Sheets on non-food products defined to be hazardous. Products \*  
 \* such as cleaning products and pesticides are included in the scope of the \*  
 \* Standard. In compliance with the law. MSDS are available to US Foods, Inc. \*  
 \* customers and can be obtained by contacting the Procurement Manager in our \*  
 \* district office or by advising your sales representative. \*  
 \* You may contact HAZMAT HOTLINE at phone # (800) 424 - 8802. \*  
 \*  
 \*\*\*\*\*

PRODUCT TOTAL \$ 47.67

TAXABLE AMOUNT \$ 00  
 GEN SALES TAX % 00

This amount is an estimate at time of shipping prior to any adjustments made at delivery: \$ 47.67

*[Handwritten Signature]*  
 000  
 240-1340 = 47.67



ACCOUNT NO. 91221150 INVOICE NO. 2584393 INVOICE DATE 01/21/25 CUSTOMER NO. 11221140 PURCHASE ORDER NUMBER

ORDER SALES DATE LOC. REP. ORDERED 7055 0972 01/19/25

Route: 2325 /

ORDER NUMBER 57568

Bill To: 90 VILLAGE COMM DEV DISTR  
3989 EAGLE LANDING PKWY  
ORANGE PARK FL 32065  
Att: CHRIS COLLETTI

Ship To: TRN EAGLE LANDING RLY CLUB  
3989 EAGLE LANDING PKWY  
ORANGE PARK FL 32065  
904 291 5600  
DEPT # 00

Remit To: US Foods, Inc  
P O BOX 198421  
ATLANTA GA 30384-8421  
770 763 1304

Ship From: 5425 S. WILLIAMSON BLVD PORT ORANGE FL 32127 Ship Date: 01/21/25 Page 03 of 05  
Special Instructions: DRIVER MUST LEAVE FINAL RECEIPT FOR INV CHANGES

Qty	Qty	Sales	Product	Description	Pack	Size	Label	Weight	Pricing	Unit	Extended
Ordered	Shipped	Unit	Number						Plan	Price	Price

STORAGE LOCATION RECAP(N)

TOTAL DRY	PIECES ORDERED:	29	PIECES SHIPPED:	29	ITEMS SHIPPED:	22	912.93
TOTAL REFRIGERATED	PIECES ORDERED:	15	PIECES SHIPPED:	15	ITEMS SHIPPED:	12	664.74
TOTAL FROZEN	PIECES ORDERED:	25	PIECES SHIPPED:	25	ITEMS SHIPPED:	21	1188.49

\*\*\* INVOICE SUMMARY \*\*\*  
TOTAL NET WGT: 1184.13 PIECES ORDERED: 69 PIECES SHIPPED: 69 ITEMS SHIPPED: 55  
TOTAL GROSS WGT: 1293.91

\*\*\*\*\*  
\* Federal Occupation Safety and Health Standards, Section 1910.1200 on Hazard \*  
\* Communication requires manufacturers and distributors to provide Material \*  
\* Safety Data Sheets on non-food products defined to be hazardous. Products \*  
\* such as cleaning products and pesticides are included in the scope of the \*  
\* Standard. In compliance with the law, MSDS are available to US Foods, Inc \*  
\* customers and can be obtained by contacting the Procurement Manager in our \*  
\* district office or by advising your sales representative \*  
\* You may contact HAZMAT HOTLINE at phone # (800) 424 - 6802 \*  
\*\*\*\*\*

PRODUCT TOTAL \$ 2766.16

TAXABLE AMOUNT \$ 00.00  
TN SALES TAX .00

This amount is an estimate at time of shipping prior to any adjustments made at delivery: \$ 2766.16

000  
240-1340 = 2375.22  
240-7444 = 194.00  
500-7450 = 196.94

Total = 2766.16

ACCOUNT NO. 91221150    INVOICE NO. 2534393    INVOICE DATE 01/21/25    CUSTOMER NO. 11221140    SHIPMENT NO.    SALES DOC 3055    SALES REP 0332    DATE ORDERED 01/17/25

Route 2325 / 4    ORDER NUMBER: 57048

Bill To: BO VILLAGE COMM DEV DISTR  
3989 EAGLE LANDING PKWY  
ORANGE PARK FL 32065

Ship To: TRN EAGLE LANDING SLP #R  
3989 EAGLE LANDING PKWY  
ORANGE PARK FL 32065  
904 291 5600  
DEPT # 03

Comit To: US Foods Inc  
P O BOX 198421  
ATLANTA GA 30384-8421  
334 767 1304

Ship From: 5425 S. WILLIAMSON BLVD. PORT ORANGE FL 32129    Ship To: 01/21/25    Pack Size:    Label:    Unit:    Extended:    Page 01 of 05

Terms: NET 21 DAYS    Driver MUST LEAVE FINAL RECEIPT FOR INV CHANGES

Qty Shipped    Sales Unit    Product Number    Description    Pack Size    Label    Weight    Pricing    Unit Price    Extended Price

HAZARDOUS MATERIALS

1	CS	2840726	DRY DETERGENT, COMBR SOLID POWER 4/5 LB 0454-SODIUM HYDROXIDE, SOLID MIXTURE	4/5 LB	ECOLAS	CS	137.0200	chem	137.02
TOTAL HAZARDOUS WEIGHT:		36.00	TOTAL HAZARDOUS PIECES:		1	TOTAL HAZARDOUS LBS:		.88	

1	CS	0719427	DRY LID, CUP 12-20 Z PLST WHT SLD 10/100 EA	10/100 EA	MUNDOGRAM	CS	27.3900		27.39 ✓
2	EA	0778670	WRAP, 10.75X10 WAX PAPER WHT	500 EA	MUNDOGRAM	EA	5.9300		11.86 ✓
1	CS	1052380	MAYONNAISE, SS POUCH	508/12 CS	HEINZ	CS	47.2500		47.25
1	CS	1259381	RICE, JASMN RAW IMP TLAND	20 LB	ROLAND	CS	28.6600		28.66
2	CS	1328699	SHORTENING, FRYG SOYAN LIQ CL 235 LB	235 LB	HARVEST W	CS	31.4900		62.98
1	CS	2008860	MUSTARD, YLW SS POUCH	500/2 OZ	HEINZ	CS	15.6200		15.62
1	CS	2837239	CHIP, ASST SS BAG SHLF STABL	2/30 EA	FRITO LAY	CS	41.0800		41.08
2	CS	3554565	DRINK, SODA COLA COKE CLSC CAN 24/12 OZ	24/12 OZ	COKE	CS	18.2900		36.58
1	CS	5051568	TORTILLA, CHIP RAW 4 CUT TRI	33 LB	LA BONDITA	CS	31.1700		31.17
1	CS	5175377	SAUCE, BUFLD HOT RED PLST JUG	4/1 GA	FRANK'S	CS	35.2400		35.24
2	CS	5451351	GLOVE, VINYL XL PF CLR AMBX	10/100 EA	VALIGARDE	CS	21.5700		43.14 ✓
1	CS	5735121	COOKIE, OTML RAI 2.5 Z IW SS	40/2.5 OZ	GRANDMA'S	CS	34.9000		34.90
1	CS	6017834	JELLY, ASST #4 SS CUP	200/6 500 OZ	SMUCKERS	CS	13.9900		13.99
2	CS	6345599	DETERGENT, BAR GLS MNL BEER	100/7.5 OZ	DIVERSEY	CS	33.4900	chem	66.98
1	CS	6729776	KETCHUP, TMTD FCY 33X RED SOZ	14/14 OZ	HEINZ	CS	31.2100		31.21
1	CS	7150345	BREADER, SEAFD BAG SPL	25 LB	HSE AURI	CS	25.8200		25.82 ✓
1	CS	7802523	NAPKIN, DAMR WHT 17X17 1 PLY	20/250 EA	VALU PLUS	CS	53.9400		53.94 ✓
2	EA	8003956	SAUCE, TYKI GLAZ PLST JUG SHLF	5 LB	KIKKOMAN	EA	3.9600		7.92 ✓
1	CS	8204505	DRINK, RSP BLU COOL PLST BTL	24/20 BT	GATORADE	CS	35.1700		35.17
1	CS	8600645	CUP, PET PLST 12 Z CLD CLR	20/50 EA	DAKT	CS	60.4100		60.41 ✓
1	CS	9937873	SAUCE, NAMBO NARAN GLTN/FR	2/7.5 GA	SWEET RAY	CS	47.9200		47.92
1	CS	1919740	REFRIGERATED COLESLAW, SHRD SHORT SWT DIXIE 2/4.5 LB READY TO EAT - Please Refer to Return Policy	2/4.5 LB	MOLLYS KIT	CS	18.4900		18.49
2	CS	2721173	CHICKEN, WING 182GT JMB RAW	4/10 LB	PATUXENT	CS	95.2200		190.44
2	CS	2725711	CHICKEN, BRST SHG, 6 Z BALS	4/5 LB	PATUXENT	CS	55.1100		110.22
1	CS	2971551	HAM, SLCD .67 Z W/A SMKD CKD	6/2 LB	HILLSHIRE	CS	48.2900		48.29

ACCOUNT INVOICE INVOICE CUSTOMER PURCHASE ORDER  
 NO. NO. DATE NO. NUMBER  
 71221150 2584393 01/21/25 11221140

SALES SALES DATE  
 LOC REP. ORDERED  
 3052 0032 01/21/25

Route: E325 / A

ORDER NUMBER 17542

Bill To: 80 VILLAGE COMM DEV DISTR  
 3989 EAGLE LANDING PKWY  
 ORANGE PARK FL 32065  
 Attn: CHRIS COLLETTI

Ship To: TRN EAGLE LANDING S - CLP  
 3989 EAGLE LANDING PKWY  
 ORANGE PARK FL 32065  
 904 291 5600  
 DEPT # 00

Remit To: US Foods, Inc  
 P O BOX 192421  
 ATLANTA GA 30384-8421  
 800 763 1304

Ship From: 5425 S. WILLIAMSON BLVD PORT ORANGE FL 32129 Date: 01/21/25 Page 02 of 05  
 Terms: NET 21 DAYS Special DRIVER MUST LEAVE FINAL RECEIPT FOR INV CHANGES

Qty	Sales	Product	Description	Pack Size	Label	Weight	Pricing Unit	Unit Price	Extended Price
1	CS	3177990	READY TO EAT - Please Refer to Return Policy						
1	CS	3331998	SALAD, PTATO ONTRY NO HFCS REF2 4/3 LB	4/3 LB	MULLYS KIT		CS	35.1700	35.17
1	CS	4326690	READY TO EAT - Please Refer to Return Policy						
1	EA	4342010	BROCCOLI, FLORT MINI ICELS REF4 1/3 LB	1/3 LB	CROSS VALY		CS	31.0100	31.01
1	CS	4326690	READY TO EAT - Please Refer to Return Policy						
1	EA	4342010	ONION, RED JMR FRESH REF 25 LB	25 LB	CROSS VALY		CS	24.4100	24.41
1	EA	4342010	CARROT, MTSTK SHRD FRESH REF 4/5 LB	4/5 LB	CROSS VALY		EA	6.9600	6.96
1	CS	5326418	READY TO EAT - Please Refer to Return Policy						
2	CS	5327275	LETTUCE, RMN FRESH REF 24 EA	24 EA	CROSS VALY		CS	30.4200	30.42
1	EA	7331614	BEEF, PTY GRND 30/20 2:1 RND 20/3 OZ	20/3 OZ	STLNH TWT		CS	43.2100	43.21
1	EA	7331614	CELERY, STICK 4" FRESH REF 4/5 LB	4/5 LB	CROSS VALY		EA	10.6300	10.63
1	CS	9124520	READY TO EAT - Please Refer to Return Policy						
1	CS	9124520	DRESSING, RANCH HMSTY PLST JAR4/1 GA	4/1 GA	KEN'S		CS	46.0800	46.08
1	CS	9124520	READY TO EAT - Please Refer to Return Policy						
1	CS	0068106	FROZEN						
1	CS	0468239	POTATO, HRN TATER NUGT 4/5 LB	4/5 LB	MUNARCH		CS	56.0700	56.07
1	CS	1054265	ROLL, HOGI WHT 9" SLCD BKD FZNG/6/3.7 OZ	6/3.7 OZ	CONTINED 2		CS	31.0200	31.02
1	CS	1570108	BUN, HOT DOG WHT 6" SLCD CKD 8/12/1.7 OZ	8/12/1.7 OZ	HILLTOP HR		CS	25.6000	25.60
1	CS	2122328	APPETIZER, CHS CHEDR BRDD GRL 2/5 LB	2/5 LB	CROSS VINE		CS	54.2900	54.29
1	CS	2122328	BEEF, STK TRD TP CC 1184B 60ZA24/6 OZA	60ZA	STUCK PROS	9.19	LB	11.4200	104.95
1	CS	2633394	CS: 0001 9.19 LRS						
1	CS	2633394	BREAD, RYE MRBL 17 SLCD 5/8" 8/30 OZ	8/30 OZ	EURO BAKRY		CS	37.7300	37.73
1	CS	2680300	POTATO, SLCD 1/10" SKON RAW 4/3 LB	4/3 LB	MUNARCH		CS	52.7100	52.71
4	CS	2883130	POTATO, FF SC 3/8" EXTRA CRSPY 5/5 LB	5/5 LB	MUNARCH		CS	50.1300	200.52
1	CS	3206145	SALMON, ATLNTC 6 Z PTN PRO 3D 12 LB	12 LB	HARBOR BHK		CS	100.1800	100.18
1	CS	3330099	HOT DOG, AB 6:1 6" RLR GRIL 10 LB	10 LB	FATUXENT		CS	30.8600	30.86
1	CS	4358495	BACON, PORK 18-22C SLCD LAID 3013 LB	3013 LB	FATUXENT		CS	52.6100	52.61
1	CS	5366760	BREAD, WHT 12.5" 21 SLCD 9/16" 4/28.32 OZ	4/28.32 OZ	ROTELLA		CS	26.0900	26.09
1	CS	5915319	APPETIZER, CHS MOZZ BRDD 6/3 LB	6/3 LB	LANE WESTN		CS	64.9800	64.98
1	CS	6442845	APPETIZER, CLFWR BTRD SPICY 3/3 LB	3/3 LB	MULLYS KIT		CS	33.5600	33.56
2	CS	6553758	ROLL, KSP WHT 4.5" SLCD BKD 6/8/3 5 OZ	6/8/3 5 OZ	ROTELLA		CS	31.6200	63.24
1	CS	6917804	APPETIZER, BEAN GRN BTRD ONION 6/2 LB	6/2 LB	MULLYS KIT		CS	48.2400	48.24
1	CS	7143805	RICE, VOTRM FRIED CKD BOIL IN 4/3 LB	4/3 LB	MIW		CS	39.5000	39.50
1	CS	7165830	POTATO, SKN BOAT 200 CT BKD 15 LB	15 LB	LANE NARL		CS	52.0500	52.05
1	CS	7233562	MACARONI 2 CHEESE, CHEDR PROCKO 36.7 OZ	36.7 OZ	MIW		CS	34.9100	34.91
1	CS	7637713	CHICKEN, TNDLN BTRD FRITK BEEK 2/5 LB	2/5 LB	FATUXENT		CS	39.5600	39.56
1	CS	7946221	MANGO, CURE 3/3" IMP MEXG IRF 2/1 12	2/1 12	MUNARCH		CS	32.3400	32.34

ACCOUNT NO. 91221150 INVOICE NO. E584394 INVOICE DATE 01/21/25 CUSTOMER NO. 11221100 PURCHASE ORDER NUMBER SALES LOC 3055 SALES REP. 0932 DATE ORDERED 01/19/25

Route 2325 / 6

ORDER NUMBER 07471

Bill To: 50 VILLAGE COMM DEV DISTR  
3989 EAGLE LANDING PKWY  
ORANGE PARK FL 32065  
Att: CHRIS COLLETTI

Ship To: TRN EAGLE LANDING GLE CLR  
3989 EAGLE LANDING PKWY  
ORANGE PARK FL 32065  
904 291 5600  
DEPT # 00

REG 15 To: US Foods, Inc.  
P.O. BOX 125121  
ATLANTA, GA 30384-8421  
386 763 1304

Ship From: 5425 S WILLIAMSON BLVD PORT ORANGE FL 32127  
Special DRIVER MUST LEAVE FINAL RECEIPT FOR INV CHANGES  
Terms: NET 21 DAYS  
Order Qty Sales Product Description Pack Size Label Weight Pricing Unit Extended Price

1	CS	9643842	FROZEN POTATO, AU GRN BKD TRAY FZN	60/4 Oz	KANUBS	LS	93.4400	\$	93.44
---	----	---------	------------------------------------	---------	--------	----	---------	----	-------

STORAGE LOCATION RECAP(N)

TOTAL FROZEN	PIECES ORDERED:	1	PIECES SHIPPED	1	ITEMS SHIPPED	1	93.44
--------------	-----------------	---	----------------	---	---------------	---	-------

TOTAL NET WGT:	15.00	*** INVOICE SUMMARY ***	PIECES ORDERED:	1	PIECES SHIPPED:	1	ITEMS SHIPPED	1	93.44
TOTAL GROSS WGT:	19.25								

PRODUCT TOTAL \$ 93.44

\*\*\*\*\*  
\* Federal Occupation Safety and Health Standards, Section 1910.1200 on Hazard  
\* Communication requires manufacturers and distributors to provide Material  
\* Safety Data Sheets on non-food products defined to be hazardous. Products  
\* such as cleaning products and pesticides are included in the scope of the  
\* Standard. In compliance with the law, MSDS are available to US Foods, Inc.  
\* customers and can be obtained by contacting the Procurement Manager in our  
\* district office or by advising your sales representative.  
\* You may contact HAZMAT HOTLINE at phone # (800) 424 - 8802  
\*\*\*\*\*

TRAY SOLD AMOUNT \$ 00  
DEM SALES TAX 2 00

This amount is an estimate at time of shipping and is subject to change at delivery \$ 93.44

*[Handwritten Signature]*  
240-1340 = 93.44  
000



9I - South Village CDD dba Eagle Landing      Pg 1  
 1000 - Golf Operating Account  
 Check Register for Jan 1/25 thru Jan 31/25  
 Manual/QUIK Checks

Check	Issued to:	Date	Check Amount
685463	HUNTINGTON NATIONAL BANK	Jan 5/25	393.95
685464	HUNTINGTON NATIONAL BANK	Jan 5/25	11,578.04
685476	COMCAST-CHARLOTTE	Jan 2/25	699.06
685482	BREAKTHRU BEVERAGE FL	Jan 7/25	786.86
685485	SOUTHERN GLAZER S OF FL (ACH ONLY)	Jan 3/25	612.00
685489	AMERICAN MARKETING & PUBLISHING	Jan 14/25	1,350.00
685490	BREAKTHRU BEVERAGE FL	Jan 14/25	281.35
685491	CHAMPION BRANDS INC (ACH ONLY)	Jan 7/25	327.00
685492	CHAMPION BRANDS INC (ACH ONLY)	Jan 7/25	97.02
685493	NORTH FLORIDA SALES (ACH)	Jan 7/25	836.75
685494	CHAMPION BRANDS INC (ACH ONLY)	Jan 7/25	660.65
685495	SOUTHERN GLAZER S OF FL (ACH ONLY)	Jan 8/25	3,718.26
685496	CHAMPION BRANDS INC (ACH ONLY)	Jan 9/25	80.00
685497	AT&T	Jan 18/25	247.67
685500	CHAMPION BRANDS INC (ACH ONLY)	Jan 14/25	442.50
685501	NORTH FLORIDA SALES (ACH)	Jan 14/25	490.50
685502	CHAMPION BRANDS INC (ACH ONLY)	Jan 22/25	308.00
685503	CHAMPION BRANDS INC (ACH ONLY)	Jan 14/25	89.10
685504	SOUTHERN GLAZER S OF FL (ACH ONLY)	Jan 15/25	1,872.90
685505	CHAMPION BRANDS INC (ACH ONLY)	Jan 16/25	214.00
685506	CHAMPION BRANDS INC (ACH ONLY)	Jan 17/25	164.00
685507	COMCAST-CHARLOTTE	Jan 22/25	737.59
685508	BREAKTHRU BEVERAGE FL	Jan 21/25	515.95
685509	NORTH FLORIDA SALES (ACH)	Jan 21/25	574.45
685510	CHAMPION BRANDS INC (ACH ONLY)	Jan 21/25	125.05
685511	CHAMPION BRANDS INC (ACH ONLY)	Jan 21/25	279.00
685512	CHAMPION BRANDS INC (ACH ONLY)	Jan 21/25	504.40
685513	BREAKTHRU BEVERAGE FL	Jan 28/25	494.04
685514	CLAY CO UTILITY AUTHORITY	Jan 29/25	75.81
685515	CLAY CO UTILITY AUTHORITY	Jan 29/25	2,527.32
685516	CLAY CO UTILITY AUTHORITY	Jan 29/25	63.39
685517	CLAY CO UTILITY AUTHORITY	Jan 29/25	88.72
685518	CLAY CO UTILITY AUTHORITY	Jan 29/25	70.74
685519	COMCAST-CHARLOTTE	Jan 31/25	336.26
685520	CHAMPION BRANDS INC (ACH ONLY)	Jan 28/25	227.52
685521	CHAMPION BRANDS INC (ACH ONLY)	Jan 28/25	480.40
685522	CHAMPION BRANDS INC (ACH ONLY)	Jan 28/25	653.00
685523	NORTH FLORIDA SALES (ACH)	Jan 28/25	243.25
685524	SOUTHERN GLAZER S OF FL (ACH ONLY)	Jan 29/25	1,501.52
685525	BREAKTHRU BEVERAGE FL	Jan 30/25	90.20
685527	FIRST INSURANCE FUNDING	Jan 3/25	2,176.60
685528	TROON GOLF LLC	Jan 15/25	16,313.25
685530	SOUTHERN GLAZER S OF FL (ACH ONLY)	Jan 24/25	1,979.68
685531	CLAY ELECTRIC COOPERATIVE	Jan 31/25	9,350.00
685532	CLAY ELECTRIC COOPERATIVE	Jan 30/25	89.95
685533	CLAY ELECTRIC COOPERATIVE	Jan 30/25	200.74
685534	CLAY ELECTRIC COOPERATIVE	Jan 30/25	446.59

9I - South Village CDD dba Eagle Landing Pg 2  
1000 - Golf Operating Account  
Check Register for Jan 1/25 thru Jan 31/25  
Manual/QUIK Checks

Check	Issued to:	Date	Check Amount
685535	CLAY ELECTRIC COOPERATIVE	Jan 30/25	1,066.41
685536	CLAY ELECTRIC COOPERATIVE	Jan 30/25	1,777.05
Total Manual/QUIK Checks Issued			----- 68,238.49

===== End of Report =====





## Invoice Number: 1464455

Customer Name: **South Village Community Development District**  
Account ID: **708528**  
Billing Zip Code: **32065-2641**

### We appreciate your business!

If you have any questions regarding this invoice, please contact us at [EFCustomerService@huntington.com](mailto:EFCustomerService@huntington.com)

Attention To:  
Invoice Date: **14-JAN-2025**  
Due Date: **05-FEB-2025**

---

Total Due: **393.95**

---

### Remittance Instructions

#### Pay by Wire

The Huntington National Bank  
ABA: 044000024  
Account: 01893251311

#### Pay by Check

Send by mail to:  
L-3708  
Columbus, OH 43260-3708

Make checks payable to:  
The Huntington National Bank

Please include your invoice number with wire information. Please send remittance information to [HTF-Remittance@Huntington.com](mailto:HTF-Remittance@Huntington.com).

### Invoice Summary

Description	Amount USD	Tax USD	Total USD
Rent	393.95	0.00	393.95
<b>Total</b>	<b>393.95</b>	<b>0.00</b>	<b>393.95</b>

### Messages:

Thank you for your business! Should you have any questions regarding your invoice, or your account please reach out using the contact details below.

### Contact Us

**Courier/Inquiry Address:** Lockbox Dept – GW2W10 (L-3708), 7 Easton Oval,  
Columbus, OH 43219

**Pay by Check:** L-3708 Columbus, OH 43260-3708

**Inquiry Email:** [EFCustomerService@huntington.com](mailto:EFCustomerService@huntington.com)

**Billing/Payment Portal:** <https://huntington.billerig.com/ebpp/HTF>

To set up an account, please use your Account ID and Billing Zip Code on the top of the invoice



## Invoice Number: 1460662

Customer Name: **South Village Community Development District**  
Account ID: **708528**  
Billing Zip Code: **32065-2641**

### We appreciate your business!

If you have any questions regarding this invoice, please contact us at [EFCustomerService@huntington.com](mailto:EFCustomerService@huntington.com)

Attention To:  
Invoice Date: **13-JAN-2025**  
Due Date: **04-FEB-2025**

---

Total Due: **11,578.04**

---

### Remittance Instructions

#### Pay by Wire

The Huntington National Bank  
ABA: 044000024  
Account: 01893251311

#### Pay by Check

Send by mail to:  
L-3708  
Columbus, OH 43260-3708

Make checks payable to:  
The Huntington National Bank

Please include your invoice number with wire information. Please send remittance information to [HTF-Remittance@Huntington.com](mailto:HTF-Remittance@Huntington.com).

### Invoice Summary

Description	Amount USD	Tax USD	Total USD
Rent	11,578.04	0.00	11,578.04
<b>Total</b>	<b>11,578.04</b>	<b>0.00</b>	<b>11,578.04</b>

### Messages:

Thank you for your business! Should you have any questions regarding your invoice, or your account please reach out using the contact details below.

### Contact Us

**Courier/Inquiry Address:** Lockbox Dept – GW2W10 (L-3708), 7 Easton Oval, Columbus, OH 43219

**Pay by Check:** L-3708 Columbus, OH 43260-3708

**Inquiry Email:** [EFCustomerService@huntington.com](mailto:EFCustomerService@huntington.com)

**Billing/Payment Portal:** <https://huntington.billerig.com/ebpp/HTE>

To set up an account, please use your Account ID and Billing Zip Code on the top of the invoice



Account Number  
8495 74 144 1037847

Billing Date  
Dec 05, 2024

Services From  
Dec 15, 2024 to Jan 14, 2025

Page  
1 of 6

# Hello Golf Course Eagle Landing,

Thanks for choosing Comcast Business.

## Your bill at a glance

For \$989 EAGLE LANDING PKWY, ORANGE PARK, FL, 32065-2641

Previous balance		\$699.16
One-time EFT Payment - thank you	Nov 20	-\$699.16
<b>Balance forward</b>		<b>\$0.00</b>
Regular monthly charges	Page 3	\$664.65
Taxes, fees and other charges	Page 3	\$34.41
<b>New charges</b>		<b>\$699.06</b>

**Amount due Dec 26, 2024 \$699.06**

### Need help?

Visit [business.comcast.com/help](https://business.comcast.com/help) or see page 2 for other ways to contact us.

## Your bill explained

- This page gives you a quick summary of your monthly bill. A detailed breakdown of your charges begins on page 3.
- Any payments received or account activity after Dec 05, 2024 will show up on your next bill. View your most up-to-date account balance at [business.comcast.com/myaccount](https://business.comcast.com/myaccount).

*SW-7810  
8  
12/23/24*

Detach the bottom portion of this bill and enclose with your payment

Please write your account number on your check or money order

Do not include correspondence with payment



1100 NORTHPOINT PKWY W PALM  
BCH FL 33407-1937  
9839010 NO RP 05 20241205 NNNNNNNY 000111 0001

EAGLE LANDING GOLF COURSE  
3989 EAGLE LANDING PKWY  
ORANGE PARK FL 32065-2641

Account number **8495 74 144 1037847**  
Payment due **Dec 26, 2024**

Please pay **\$699.06**

Amount enclosed \$

Make checks payable to Comcast  
Do not send cash



Send payment to  
COMCAST  
PO BOX 71211  
CHARLOTTE NC 28272-1211

**Regular monthly charges \$664.65**

<b>Comcast Business</b>	<b>\$585.75</b>
TV Basic Business Video.	\$50.95
Business Internet 1g	\$499.95
Service Discount	<del>-\$60.00</del>
Static IP - 1	\$24.95
Basic Voice Line Business Voice.	\$24.95
Mobility Voice Line Business Voice.	\$44.95

<b>Equipment &amp; services</b>	<b>\$32.90</b>
TV Adapter	\$9.95
Equipment Fee Voice.	\$22.95

<b>Service fees</b>	<b>\$46.00</b>
Directory Listing Management Fee	\$6.00
Voice Network Investment	\$6.00
Broadcast TV Fee	\$34.00

**Taxes, fees and other charges \$34.41**

<b>Other charges</b>	<b>\$5.99</b>
Regulatory Cost Recovery	\$3.89
Federal Universal Service Fund	\$2.10

<b>Taxes &amp; government fees</b>	<b>\$28.42</b>
Sales Tax	\$2.47
State Communications Services Tax	\$12.81
Local Communications Services Tax	\$11.56
Federal Excise Tax	\$0.78
911 Fees	\$0.80

**What's included?**

 **Internet:** Fast, reliable internet on our Gig-speed network

 **TV:** Keep your employees informed and customers entertained

 **Voice Numbers:** (904)375-9741, (904)375-8900

Visit [business.comcast.com/myaccount](https://business.comcast.com/myaccount) for more details

You've saved \$60.00 this month with your service discount.





**Important information regarding  
Comcast Business services and pricing  
Effective December 18, 2024**

Dear Comcast Business Customer:

At Comcast Business, we continue to make investments in our network, technology, and people to ensure we maintain a high-quality network for our customers. We strive to provide the best services and make significant efforts to help control your service-related costs.

From time to time, we re-evaluate our pricing structure due to programming, technology, and service improvements. As a result, monthly service charges and fees have been adjusted for the services below.

**Pricing updates based on your subscribed services will occur on December 18, 2024.  
Prices do not include applicable taxes and other fees.**

**Comcast Business Video**

Service	Current Monthly Service Charge:		New Monthly Service Charge Effective 12/18/2024:
Public View	\$20.00	>	<b>\$25.00</b>
Basic	\$50.95	>	<b>\$65.95</b>
Select	\$57.95	>	<b>\$72.95</b>
Variety	\$74.95	>	<b>\$89.95</b>
Standard	\$99.95	>	<b>\$114.95</b>
Preferred	\$124.95	>	<b>\$139.95</b>
Broadcast TV Fee (BTV)	Charges vary by location	>	Charges vary by location
Regional Sports Network (RSN)	Charges vary by location	>	Charges vary by location

**Hospitality Video**

Fees	Current Monthly Fee:		New Monthly Fee Effective 12/18/2024:
HBO	\$3.50	>	<b>\$5.50</b>
Showtime	\$3.50	>	<b>\$5.50</b>
Basic	\$2.00	>	<b>\$4.00</b>

**Comcast Business Voice**

Service	Current Monthly Service Charge:		New Monthly Service Charge Effective 12/18/2024:
Directory Listing Management Fee	\$6.00	>	<b>\$8.00</b>
Voice Network Investment Fee	\$6.00	>	<b>\$8.00</b>

**Comcast Business Internet**

Service	Current Monthly Service Charge:		New Monthly Service Charge Effective 12/18/2024:
Static IP (1)	\$24.95	>	<b>\$29.95</b>
Static IP (5)	\$29.95	>	<b>\$34.95</b>





EAGLE LANDING GOLF CLUB  
 CGMP MANAGERS II LLC  
 3989 EAGLE LANDING PKWY  
 ORANGE PARK FL 32065  
 PH: 904-291-5600



6031 Madison Avenue  
 Tampa, FL 33619  
 Phone: (813) 672-6161

FED# FL-P-21520  
 IMP# FL-I-21446  
 STATE#KLD3900175

ACH



CUSTOMER #	INVOICE DATE	INVOICE #
700026767	1/07/2025	119476895

All requests for returns must be in writing within 10 days of delivery.

ROUTE	STOP	SPECIAL INSTRUCTIONS	PURCHASE ORDER #	REP	DUE DATE	CREDIT TERMS					
2329	21	DELIVER 7 AM - 6 PM.		0792	01/20/25	EFT NET 10 days					
ITEM #	#CASE	#BTL	SIZE	DESCRIPTION	UPC	PACK	UNIT	DISCOUNT	NET CASE	NET BOTTLE	EXTENDED AMOUNT
9009224		1	1L	DI AMORE AMARETTO BAR 1L		12	16.70			16.70	16.70
9611931		20	50ML	JACK DANIELS BLK PET WRAP 12/10PK 50ML		120	2.39			2.39	47.80
21733		2	1L	WOODFORD RSV BREN 6B 1L		6	46.33			46.33	92.66
9031302	1		1L	BUFFALO TRACE BRN 1L		12	288.00		288.00	24.00	288.00
9031406	1		1L	FIREBALL CINN WHSKY 1L		12	198.00	24.00	174.00	14.50	174.00
9220188	1		50ML	FIREBALL CINN WHSKY PET 12/10PK 50ML		120	73.20		73.20	0.61	73.20
9236294	1		750ML	STIRRINGS MARG MIXER 5 CAL NA 6B 750ML		6	31.50		31.50	5.25	31.50
9088350	2		750ML	STIRRINGS MARG MIXER NA 6B 750ML		6	31.50		31.50	5.25	63.00

*Lot # 1171*  
*Lot # 1171*  
*Lot # 1171*

*Return 1/2/25*  
~~Case 240-1340- 94.50~~  
~~Case 240-1346- 692.34~~

*Lot # 1171*

To offset rising operational costs and maintain the highest level of service, BBG-FL will implement minor split case and delivery fee adjustments effective 1/15/24.

Customer Signature:

Thank you for your order. We appreciate your business.

Cases	Bottles	T Bottles	Empty Keg Returns	Access PAY NOW, Breakthru's online payment portal to manage invoice payments.	License #	Sales Tax #	Discount	Total Amount Due
ZOR	6	23	105		2001434 11CG	999999	24.00	786.86

Facebook [www.facebook.com/breakthrubevFL](https://www.facebook.com/breakthrubevFL)  
 Twitter @breakthrubevFL  
 Instagram [www.instagram.com/breakthrubevFL](https://www.instagram.com/breakthrubevFL)

Visit now [www.breakthrubev.com](http://www.breakthrubev.com)  
 to register your account today!



STATE BEVERAGE LAWS REQUIRE FULL PAYMENT OF THIS INVOICE ON OR BEFORE DUE DATE SHOWN. PAYMENTS MADE AFTER DUE DATE, RETURNED PAYMENTS AND PAST DUE INVOICES WILL RESULT IN LOST DISCOUNTS AND THE GROSS TOTAL WILL BE DUE. CUSTOMERS RESPONSIBLE FOR ALL COSTS OF COLLECTION. IN THE EVENT SUIT IS FILED TO RECOVER AN UNPAID BALANCE, CUSTOMERS RESPONSIBLE FOR ALL COSTS, INTEREST AND REASONABLE ATTORNEY'S FEES.



SOUTHERN GLAZER'S OF FL  
4440 OLD TAMPA HIGHWAY  
LAKELAND, FLORIDA  
33811

REMIT TO:  
SOUTHERN GLAZER'S OF FL  
P.O. BOX 947921  
ATLANTA, GA 30394-7921  
1-866-375-9555

ACH



INVOICE NUMBER	6088706	
ACCOUNT NUMBER	85510	
ROUTE	500	STOP 16

S EAGLE LANDING GOLF CLUB  
O 3989 EAGLE LANDING PARKWAY  
L ORANGE PARK FL 32065  
D

S EAGLE LANDING GOLF CLUB  
H 3989 EAGLE LANDING PARKWAY  
I ORANGE PARK FL 32065  
P  
T O

**C.O.D.**

LAK-O TRUCK JACKSONV C.O.D. C.O.D. FINTECH

PAGE 1 OF 1  
1500 3 14

LICENSE NUMBER 20-01434	SALES PERSON 186	DLVRY INSTRUCTIONS: LAK-O TRUCK JACKSONV	PHONE NUMBER 904-291-5600	INVOICE DATE 1/03/2025
----------------------------	---------------------	---	------------------------------	---------------------------

LOC	CASES	BTLS	SIZE	DESCRIPTION	PACK	W-LOC	B-LOC	PRODUCT CODE	NET BIL PRICE	UNIT PRICE	DIV CODE	LIMIT DISCOUNT	NET AMOUNT
	2		1.0L	TITOS HANDMADE VODKA 80	12			46599	25.50	340.56	002	34.56	612.00
<p><i>Rec'd 1/3/25</i></p> <p><del>240</del> → 1346 <i>\$612.00</i></p> <p>000 <i>LIQUOR</i></p> <p style="font-size: 2em; opacity: 0.5; text-align: center;">C O D</p>													

Thank You For Your Business

CASES ORDER TOTAL	2	BOTTLES ORDER TOTAL	24	WINE GALLONS		LIQUOR GALLONS	6.34	BEER GALLONS		TOTAL # BTLS:	24	YTD TOTAL DISCOUNT:	69.12	PAY THIS AMOUNT	612.00
CARTON	2	DRIVER		LOADED		EAGLE LANDING GOLF CLUB		INVOICE NO.	1	CUSTOMER NO.		NET AMOUNT	681.12	TOTAL DISCOUNT	69.12

We warrant that the goods described in this invoice are as shown and of the quality and quantity stated. We warrant that the goods are fit for the purpose intended. We warrant that the goods are free from defects. We warrant that the goods are free from damage. We warrant that the goods are free from any other defects. We warrant that the goods are free from any other damage. We warrant that the goods are free from any other defects. We warrant that the goods are free from any other damage.



# AMERICAN MARKETING & PUBLISHING, L.L.C.

915 E. Lincoln Hwy. ■ P.O. Box 801 ■ DeKalb, IL 60115 ■ Phone: (800) 807-6870 ■ Fax: (815) 756-1821

[www.ampcorporate.com](http://www.ampcorporate.com)

## AMP Order Confirmation Form

Order # **AMP467777**

<b>Name of Advertiser</b>	Eagle Landing Golf Club	<b>Authorized Person</b>	Rachael MacNabb
<b>Customer #:</b>	19391020	<b>Email:</b>	rmacnabb@troon.com
<b>Address:</b>	3973 Eagle Landing Pkwy. Orange Park, FL 32065	<b>Website:</b>	
<b>Contact Phone/Fax:</b>	904-291-5600 /	<b>Business Category:</b>	Golf Club
<b>Acceptance Date:</b>	1/14/2025	<b>Additional Category:</b>	

This AMP Order Confirmation Form (this "Order Form") confirms the oral agreement of the above named Advertiser to purchase the products and services identified below via recorded telephone call(s), subject to the terms hereof, the General Terms and Conditions attached hereto or provided herewith ("General Terms"), and each applicable Schedule to the General Terms setting forth additional terms and conditions with respect to specific products and services ("Product Terms"). The General Terms and Product Terms are hereby incorporated into this Order Form (collectively, this "Agreement"). For convenience, the General Terms and Product Terms also may be reviewed at [www.ampcorporate.com/AdvertisingGeneralTerms&Conditions](http://www.ampcorporate.com/AdvertisingGeneralTerms&Conditions).

This Agreement is entered into between Advertiser and American Marketing & Publishing, LLC, a Delaware limited liability company ("Publisher"). Capitalized terms used but not defined in this Order Form shall have the meanings ascribed to them in the General Terms or Product Terms.

A. **Cancellation.** Other than as set forth in Sections 2(b) and 2(c) of the General Terms, Advertiser may only cancel this Agreement by providing written notice to Publisher within two days of the Acceptance Date (as set forth above, or if not set forth above, as defined in the General Terms). Such notice must be sent by an authorized representative of Advertiser as set forth and further detailed in Section 2(a) of the General Terms. **Any cancellation by Advertiser made or attempted later than two days after the Acceptance Date shall not relieve Advertiser of the obligations and responsibilities hereunder, including Advertiser's payment obligations.**

B. **Products Purchased.** Advertiser hereby confirms their purchase of, and Publisher agrees to provide, the following Products subject to this Agreement:

Product	Description	Minimum Term	Ref Sched	Today's Annual Price	Discount	Estimated Sales Tax	Product Sub-Total
Premium CloseBy™ Text Marketing Program	Twelve months of cloud based messaging platform access to promote one location, with unlimited subscribers, a unique 10 digit number, technical assistance from a Dedicated Account Manager, three vanity codes, and enhanced messaging including Birthday Club and message targeting. Includes up to 100,000 messages per year that may be used to promote one location; messages cost 1.5 cents thereafter.	Annual	D	\$1,350.00	N/A	N/A	\$1,350.00
<b>Total</b>				<b>\$1,350.00</b>	(N/A)	N/A	<b>\$1,350.00</b>

### C. **Payment and Payment Information.**

Advertiser agrees to pay the amounts shown above for the Products on the Acceptance Date, or in the event of delayed payment Advertiser shall pay the Publisher (or if applicable Publisher may charge or debit Advertiser) (a) in connection with GSV Tour Services, on the earlier of the date of the photoshoot or 30 days after the Acceptance date; (b) in connection with all other Products, within 30 days after the Acceptance Date; or (c) in the event of a Payment Plan, in the manner and on the timeline described below. If Publisher issues an invoice to Advertiser, the invoiced amount will be due in full, without set off, on or before the due date set forth in such invoice (or if no due date is set forth in the invoice, within 30 days after the date of the invoice).



EAGLE LANDING GOLF CLUB  
 CGMP MANAGERS 11 LLC  
 3989 EAGLE LANDING PKWY  
 ORANGE PARK FL 32065  
 PH: 904-291-5600



6031 Madison Avenue  
 Tampa, FL 33619  
 Phone: (813) 672-6161

FED# FL-P-21520  
 IMP# FL-I-21446  
 STATE#KLD3900175

\*\* INVOICE \*\*



ACH

CUSTOMER #	INVOICE DATE	INVOICE #
700026767	1/14/2025	119581001

Page 1 of 1

All requests for returns must be in writing within 10 days of delivery.

ROUTE	STOP	SPECIAL INSTRUCTIONS		PURCHASE ORDER #	REP	DUE DATE	CREDIT TERMS				
2329	26	DELIVER 7 AM - 6 PM.			0792	01/27/25	EFT NET 10 days				
ITEM #	#CASE	#DTL	SIZE	DESCRIPTION	UPC	PACK	UNIT	DISCOUNT	NET CASE	NET BOTTLE	EXTENDED AMOUNT
9329930		2	750ML	MCGUIRES IRISH CRM 750ML		12	8.85			8.85	17.70
9004654		3	1L	MR BOSTON MELON LIQ 1L		12	6.95			6.95	20.85
9004625		2	1L	SABROSO COFFEE LIQ 1L		12	11.95			11.95	23.90
3672433	1		1L	FINEST CALL PEACH PUREE NA 1L		12	54.00	6.00	48.00	4.00	48.00
9610051	2		355ML	HIGH NOON CKTL TROPICAL CAN 3/8PK 355ML		24	72.00	32.40	39.60	1.65	79.20
9435957	2		355ML	HIGH NOON SN SP VARTY CAN 3/8 355ML		24	72.00	32.40	39.60	1.65	79.20
				Delivery Charge							12.50
9031293			750ML	BLANTONS BRBN SNGL BBL 6B 750ML Out of Stock							

*[Handwritten signature]*  
 1/14/25

*[Handwritten signature]*  
 Raw  
 240-1346  
 000  
 liquor

*[Handwritten]*  
 \$ 281.35

To offset rising operational costs and maintain the highest level of service, BBG-FL will implement minor split case and delivery fee adjustments effective 1/14/25.

Customer Signature: *[Handwritten Signature]*

Thank you for your order. We appreciate your business.

Cases	Bottles	Empty Keg Returns	Access PAY NOW, Breakthru's online payment portal to manage invoice payments.	License #	Sales Tax #	Discount	Total Amount Due
ZCR	5	7	115	2001434 11CG	999999	135.60	281.35

Facebook [www.facebook.com/breakthrubevFL](http://www.facebook.com/breakthrubevFL)  
 Twitter [@breakthrubevFL](https://twitter.com/breakthrubevFL)  
 Instagram [www.instagram.com/breakthrubevFL](http://www.instagram.com/breakthrubevFL)

Visit [now.breakthrubev.com](http://now.breakthrubev.com) to register your account today!



STATE BEVERAGE LAWS REQUIRE FULL PAYMENT OF THIS INVOICE ON OR BEFORE DUE DATE SHOWN. PAYMENTS MADE AFTER DUE DATE, RETURNED PAYMENTS AND PAST DUE INVOICES WILL RESULT IN LOST DISCOUNTS AND THE GROSS TOTAL WILL BE DUE. CUSTOMERS RESPONSIBLE FOR ALL COSTS OF COLLECTION. IN THE EVENT SUIT IS FILED TO RECOVER AN UNPAID BALANCE, CUSTOMERS RESPONSIBLE FOR ALL COSTS, INTEREST AND REASONABLE ATTORNEY FEES.

Champion Brands Inc.  
 PO BOX 56260  
 Jacksonville, FL 32241  
 (904)-268-1220  
 Tue Jan 07, 2025 2:51 PM

ACH

Account: 23384      Invoice#: 3523362      PG#:  
 SOUTH VILLAGE COMMUNITY D      License : 2001434 Expires N/A  
 EAGLE LANDING GOLF CLUB      Load : 201  
 3989 EAGLE LANDING PKWAY      Terms : FINTECH  
 ORANGE PARK, FL 32065      Driver : 01 - T. FLICK  
 (904) 291-5600      Salesrep: B01 - HUNTER LABBIE

ITEM#	QTY	DESCRIPTION	U.P.C.	Disc	D.PRICE	DEP	EXT
05252	1	BLUE MOON	071990095154	5.00	171.00	30.00	201.00
		BLUE MOON 1/2 BBL 15.5 GAL					
57152	1	LITE	034100005344	11.00	123.00	30.00	153.00
		LITE 1/2 BBL 15.5 GAL					
08422	1	YUENG LAGER	089924849506	11.00	123.00	30.00	153.00
		YUENGLING LAGER 1/2 BBL 15.5 GAL					
99152	-2	MILLER RETURNS	000000000000	0.00	0.00	30.00	-60.00
		MILLER EMPTY 1/2 BBL					
99356	-2	CRAFT RETURNS	000000000000	0.00	0.00	30.00	-60.00
		CRAFT EMPTY KEGS					
99652	-1	YUENGLING RETS	000000000000	0.00	0.00	30.00	-30.00
		YUENGLING EMPTY 1/2 BBL					
99252	-1	BLUE MOON RETU	000000000000	0.00	0.00	30.00	-30.00
		BLUE MOON EMPTY 1/2 BBL					

Beer: 0 + 3 Kegs      \$507.00  
 Wine & Liq: 0      \$0.00  
 Soft Drink: 0      \$0.00  
 Misc: 0      \$0.00  
 Credits: -6      -\$180.00

*[Handwritten signature]*

*Rec'd 1/7/25*  
~~2401342~~ BEER  
 000  
 \$ 327.00

Total Selling Units:	-3
Total Sales	444.00
Total Discount	-27.00
Total Content	417.00
Total Deposit	90.00
Total Credits	-180.00
Over/Short	0.00
<b>Invoice Total</b>	<b>327.00</b>

I ACCEPT THIS PRODUCT DELIVERY IN SALEABLE CONDITION.  
 YOUR SIGNATURE IS ACCEPTANCE OF ALL ABOVE ITEMS. PLEASE CHECK CAREFULLY.  
 Thank you!

Customer Signature:

Driver Signature:

*[Handwritten signature: Flick]*

ACH

Champion Brands Inc.  
PO BOX 56260  
Jacksonville, FL 32241  
(904)-268-1220  
Tue Jan 07, 2025 3:06 PM

Account: 23384  
SOUTH VILLAGE COMMUNITY D  
EAGLE LANDING GOLF CLUB  
3989 EAGLE LANDING PKWAY  
ORANGE PARK, FL 32065  
(904) 291-5600

Invoice#: 3523359 PO#:   
License : 2001434 Expires N/A  
Load : 201  
Terms : FINTECH  
Driver : 01 - T. FLICK  
Salesrep: B01 - HUNTER LABBIE

ITEM#	QTY	DESCRIPTION	U.P.C.	Disc	D.PRICE	DEP	EXT
600002	1	WATERBIRD	860005649518	0.00	49.50	0.00	49.50
		6/4/12 RANCH WATER	WB RANCH 6/4/12 CAN				
600006	1	WATERBIRD	860005649570	1.93	47.52	0.00	47.52
		6/4/12 VODKA TRANSFUS WB VODKA TRANS	6/4				

Beer: 0 + 0 Kegs \$0.00  
 Wine & Liq: 2 \$97.02  
 Soft Drink: 0 \$0.00  
 Misc: 0 \$0.00  
 Credits: 0 \$0.00

Total Selling Units: 12  
 Total Sales 98.95  
 Total Discount -1.93  
 Total Content 97.02  
 Total Deposit 0.00  
 Total Credits 0.00  
 Over/Short 0.00  
 Invoice Total 97.02

*Handwritten signature*

*Rec'd 1/7/25*  
~~240.1346~~ 110000  
 000  
 \$97.02

I ACCEPT THIS PRODUCT DELIVERY IN SALEABLE CONDITION.  
 YOUR SIGNATURE IS ACCEPTANCE OF ALL ABOVE ITEMS. PLEASE CHECK CAREFULLY.  
 Thank you!

Customer Signature:

Driver Signature:

*Handwritten signature: Flick*



3601 Regent Blvd.

Jacksonville, FL 322  
 (904) 645-0283  
 NFDsales.net

EAGLE LANDING GOLF C  
 3989 EAGLE LANDING P

ORANGE PARK, FL 3206  
 BEV2001434  
 Brooke Simard

Stacy McClellan

Fintech

Date	Invoice	LoadSheet	Vendor	PO Num			
01/07/2025	4085146	270877		20598612			
Route	Customer	Deliverse	Salesman				
1504	101152	AMATTHEWS	API_11825				
ID	QTY	PRODUCT	PRICE	DEP	DISC	NET	TOTAL
322	2	ULTRA 1/2	\$148.30	\$30.00		\$118.30	\$236.60
325	3	BUD LT 2/12 16OZ TWST AL B	\$30.60			\$30.60	\$91.80
327	1	CORONA LIGHT 2/12 B	\$32.80			\$32.80	\$32.80
935	1	STELLA 11.2 OZ 2/12 B	\$33.35			\$33.35	\$33.35
9378	9	ULTRA 2/12 16OZ AL TW	\$35.80			\$35.80	\$322.20
5	16	BEER 71.3500 Gallons	\$60.00	\$0.00			

*[Handwritten signature]*

Rec'd J. 1/7/25

000  
~~240-1342~~ BEER  
 \$ 836.75

Total \$836.75  
 Charges \$836.75  
 Credits \$0.00  
 Total \$836.75

*[Handwritten signature]*



**Champion Brands Inc.**

PO BOX 56260  
 Jacksonville, FL 32241  
 (904)-268-1220  
 Tue Jan 07, 2025 3:06 PM

ACH

Account: 23384  
 SOUTH VILLAGE COMMUNITY D  
 EAGLE LANDING GOLF CLUB  
 3989 EAGLE LANDING PKWAY  
 ORANGE PARK, FL 32065  
 (904) 291-5600

Invoice#: 3523360 PO#:  
 License : 2001434 Expires N/A  
 Load : 201  
 Terms : FINTECH  
 Driver : 01 - T. FLICK  
 Salesrep: B01 - HUNTER LABBIE

ITEM#	QTY	DESCRIPTION	U.P.C.	Disc	D.PRICE	DEP	EXT
05176	4	COORS LIGHT	071990301064	3.25	26.25	0.00	105.00
		COORS LIGHT ALUMINUM 24/16 CAN					
85151	1	INTUITION I-10	850501003051	0.00	38.35	0.00	38.35
		INTUITION I-10 IPA 4/6/12 CAN					
48208	2	LEIN SUM SHAND	034100516093	0.00	38.35	0.00	76.70
		LEINEKUGEL SUMMER SHANDY #2/12/12 CANS					
57274	6	LITE	034100003760	3.25	26.25	0.00	157.50
		LITE ALUMINUM 24/16 CAN					
90121	1	RB EDITIONS	61126933213	0.00	41.50	0.00	41.50
		RED BULL EDITIONS RED 80Z 4PK					
90035	1	RB ENERGY DRIN	611269991000	0.00	41.50	0.00	41.50
		RED BULL ENERGY DRINK 80Z SINGLES					
90193	1	RB SF EDITIONS	611269002034	0.00	41.50	0.00	41.50
		RED BULL EDITIONS SUGAR FREE RED 80Z SINGLES					
90036	1	RB SUGAR FREE	611269101713	0.00	41.50	0.00	41.50
		RED BULL SUGAR FREE 80Z SINGLES					
19464	1	SN LITTLE THIN	083783110104	0.00	38.35	0.00	38.35
		SIERRA HAZY LITTLE THING 4/6/12 CANS					
09850	3	YUENG LAGER	089924532491	4.30	26.25	0.00	78.75
		YUENGLING LAGER 4/6/16 CAN					

*[Handwritten signature]*

Beer: 17 0 Kegs \$494.65  
 Wine & Lig: 0 \$0.00  
 Soft Drink: 4 \$166.00  
 Misc: 0 \$0.00  
 Credits: 0 \$0.00

*Rev'd 1/7/25*

Total Selling Units: 112  
 Total Sales: 706.05  
 Total Discount: -45.40

~~240~~ 1360 OTHER  
 000 \$166.00

Total Content: 660.65  
 Total Deposit: 0.00  
 Total Credits: 0.00  
 Over/Short: 0.00

~~240~~ 1342 BEER  
 000 \$494.65

Invoice Total: 660.65

I ACCEPT THIS PRODUCT DELIVERY IN SALEABLE CONDITION.  
 YOUR SIGNATURE IS ACCEPTANCE OF ALL ABOVE ITEMS. PLEASE CHECK CAREFULLY.  
 Thank you!

Customer Signature:

Driver Signature:

*[Handwritten signature]*

SOUTHERN GLAZER'S OF FL  
4440 OLD TAMPA HIGHWAY  
LAKELAND, FLORIDA  
33811

REMIT TO:  
SOUTHERN GLAZER'S OF FL  
P.O. BOX 947921  
ATLANTA, GA 30394-7921  
1-866-375-9555



INVOICE NUMBER	3609737	
ACCOUNT NUMBER	85510	
ROUTE	516	STOP 5

S EAGLE LANDING GOLF CLUB  
O 3989 EAGLE LANDING PARKWAY  
L ORANGE PARK FL 32065  
D

S EAGLE LANDING GOLF CLUB  
H 3989 EAGLE LANDING PARKWAY  
I ORANGE PARK FL 32065  
P  
T  
O

**C.O.D.** H

DUPLICATE

C O D C.O.D. FINTECH  
FINTECH

PAGE 1 OF 3  
1500 3 14

LAKELAND-NIGHT BILL

LICENSE NUMBER 20-01434	SALES PERSON 186	DELIVERY INSTRUCTIONS P.O.#:	PHONE NUMBER 904-291-5600	INVOICE DATE 1/08/2025
----------------------------	---------------------	---------------------------------	------------------------------	---------------------------

LOC	CASES	BILLS	SIZE	DESCRIPTION	PACK	W-LOC.	B-LOC.	PRODUCT CODE	NET BTL PRICE	UNIT PRICE	DIV CDE	UNIT DISCOUNT	NET AMOUNT
	1		1.0L	ARISTOCRAT VODKA 80	12			69057	6.25	128.04	080	53.04	75.00
	1		1.0L	CAPT MORGAN RUM SP MV 70	12			597191	18.50	228.00	001	6.00	222.00
	1		750ML	CHT STE MICH RIESLING HARV SELECT	12			516522	9.25	166.44	003	55.44	111.00 w
	1		750ML	CHT STE MICH SAUV BL HORSE HEAVN21	12			564849	5.00	180.00	003	120.00	60.00 w
	1		50ML	CROWN ROYAL CANADIAN 80 6P PET BAG	10			415266	13.50	166.20	001	31.20	135.00
	1		1.0L	CROWN ROYAL CANADIAN 80(BAR)	12			631498	37.00	471.00	001	27.00	444.00
	2		750ML	DON JULIO TEQ BLANCO 80	6			971835	39.08	277.02	001	42.54	468.96
	1		1.0L	GOSLINGS STORMY GINGER PET	12			301275	2.64	34.08	002	2.40	31.68 o
	1		50ML	KAHLUA 40 12/10PK PET	12			617068	19.30	231.60	005		231.60
	1		250ML	OWENS MIXERS TRANSFUSION MIX 6/4PK	6			975536	(S) BACKORDERED, REORDER				
	1		750ML	RODNEY STRONG CAB SAUV SONOMA 21	12			637530	12.00	252.00	003	108.00	144.00 w
	1		750ML	SUTTER HOME MOSCATO(SC)	12			513862	4.40	81.00	003	28.20	52.80 w
	2		1.0L	TITOS HANDMADE VODKA 80	12			46599	23.00	340.56	002	64.56	552.00
	3		50ML	TITOS HANDMADE VODKA 80 5/12PK SLV	5			974536	18.76	117.80	002	24.00	281.40

**C O D**

Thank You For Your Business

*Rec'd 1/8/25 10:50 PM  
Total on PS 3*

PAGE TOTAL	CASES ORDER TOTAL	PAGE TOTAL	BOTTLES ORDER TOTAL	WINE GALLONS	LIQUOR GALLONS	BEER GALLONS	CUSTOMER	PAGE	GROSS TOTAL	TOTAL DISCOUNT	PAY THIS AMOUNT
17	21		21				EAGLE LANDING GOLF CLUB	1			** CONT **
CARTON	DRIVER	LOADED	EAGLE LANDING GOLF CLUB		INVOICE NO.	CUSTOMER NO.					

SOUTHERN GLAZER'S OF FL  
4440 OLD TAMPA HIGHWAY  
LAKELAND, FLORIDA  
33811

REMIT TO:  
SOUTHERN GLAZER'S OF FL  
P.O. BOX 947921  
ATLANTA, GA 30394-7921  
1-866-375-9555



INVOICE NUMBER	3609737		
ACCOUNT NUMBER	85510		
ROUTE	516	STOP	5

S EAGLE LANDING GOLF CLUB  
O 3989 EAGLE LANDING PARKWAY  
L ORANGE PARK FL 32065  
D

S EAGLE LANDING GOLF CLUB  
H 3989 EAGLE LANDING PARKWAY  
I ORANGE PARK FL 32065  
P  
T  
O

**C.O.D.**

DUPLICATE  
C O D C.O.D. FINTECH  
FINTECH

PAGE 2 OF 3  
1500 3 14

LAKELAND-NIGHT BILL

LICENSE NUMBER	SALES PERSON	DELVY INSTRUCTIONS	PHONE NUMBER	INVOICE DATE
20-01434	186	P.O.F.:	904-291-5600	1/08/2025

LOC	CASES	BTLS	SIZE	DESCRIPTION	PACK	W.LOC.	B.LOC.	PRODUCT CODE	NET BTL PRICE	UNIT PRICE	DRV CODE	UNIT DISCOUNT	NET AMOUNT
	1		750ML	WOODBIDGE CAB SAUV SP COL(SC)	12			913784	4.00	87.00	007	39.00	48.00w
	1		750ML	WOODBIDGE CHARD SP COL(SC)	12			913777	4.00	87.00	007	39.00	48.00w
	1		750ML	WOODBIDGE PINOT GRIGIO SP COL(SC)	12			915650	4.00	87.00	007	39.00	48.00w
	1		32 Z	ZING ZANG BLOODY MARY MIX PET	12			972007	4.00	87.00	007	39.00	48.00w
	1		750ML	ANGELS ENVY BBN 86.6	6			404725	4.00	72.00	003	24.00	48.00w
	1		1.0L	BACARDI RUM DRAGON BERRY 70	12			240792	45.10	45.10	080		45.10
	1		1.0L	BACARDI RUM LIMON 70	12			28736	20.12	20.12	080		20.12
	1		1.0L	BACARDI RUM SUPERIOR WHITE 80	12			28728	20.12	20.12	080		20.12
	1		1.0L	BASIL HAYDENS BBN 80	6	83		895573	20.12	20.12	080		20.12
	1		1.0L	BULLEIT BOURBON 90	12			352429	51.95	54.92	003	2.97	51.95
	1		1.0L	BULLEIT 95 RYE 90	12			443649	36.95	36.95	001		36.95
	1		1.0L	COURVOISIER COG VS 80	12			407349	37.70	37.70	001		37.70
	2		1.0L	CROWN ROYAL PEACH 70(BAR)	12			631475	34.00	35.00	002	1.00	34.00
	2		1.0L	CROWN ROYAL REGAL APPLE 70 BAR	12			631461	39.45	41.70	001	2.25	78.90
									39.45	41.70	001	2.25	78.90

**C O D**

Thank You For Your Business

*Rec'd 1/8/25  
10207*

CASES	BOTTLES	WINE GALLONS	LIQUEUR GALLONS	BEER GALLONS	CUSTOMER	PAGE	GROSS TOTAL	TOTAL DISCOUNT	PAY THIS AMOUNT
4	21	12	21		EAGLE LANDING GOLF CLUB	2			** CONT **

We warrant that it is a mechanical order applicable to the products shown on the invoice and that all such products were ordered by the driver and have been received without any damage, unless noted on invoice or otherwise. DRIVER'S SIGNATURE REQUIRED FOR ALL ORDERS.



SOUTHERN GLAZER'S OF FL  
1440 OLD TAMPA HIGHWAY  
LAKELAND, FLORIDA  
33811

REMIT TO:  
SOUTHERN GLAZER'S OF FL  
P.O. BOX 947921  
ATLANTA, GA 30394-7921  
1-866-375-9555

ACH



INVOICE NUMBER	3609737		
ACCOUNT NUMBER	85510		
ROUTE	516	STOP	5

EAGLE LANDING GOLF CLUB  
3989 EAGLE LANDING PARKWAY  
ORANGE PARK FL 32065

EAGLE LANDING GOLF CLUB  
3989 EAGLE LANDING PARKWAY  
ORANGE PARK FL 32065

**C.O.D.**

DUPLICATE  
C O D C.O.D. FINTECH  
FINTECH

PAGE 3 OF 3  
1500 3 14

LICENSE NUMBER 20-01434 SALES PERSON 186 DELVRY INSTRUCTIONS: P.O.#:  
LAKELAND-NIGHT BILL PHONE NUMBER 904-291-5600 INVOICE DATE 1/08/2025

LOC	CASES	BTLS	SIZE	DESCRIPTION	PACK	W-LOC.	B-LOC.	PRODUCT CODE	NET-RTL PRICE	UNIT PRICE	DRY CDE	UNIT DISCOUNT	NET AMOUNT
	1	1.0L		DEKUYPER PUCKER WATERMELON SCHN 30	12		20513	49357	13.45	14.23	003	.78	13.45
	2	1.0L		HENNESSY COGNAC VS 80	12			344101	57.20	57.20	001		114.40
	1	1.0L		JIM BEAM BOURBON 80	12			975690	22.20	27.25	003	5.05	22.20
	2	1.0L		MALIBU RUM COCONUT 42	12		20262	33451	23.78	23.78	005		47.56
	1	1.0L		RUMPLE MINZE PEPPERMINT 100	12			365734	32.70	32.70	001		32.70
	1	1.0L		SKREWBALL WSKY PEANUT BUTTER 70	6			529073	30.20	33.20	005	3.00	30.20
	1	1.0L		TANQUERAY GIN 94.6	12		21523	278078	32.45	32.45	001		32.45

**C O D**

*Signature*

*Handwritten notes:*  
OTHER ~~240-1344~~ 511.80  
WINE ~~240-1344~~ 51.68  
LIQUOR ~~240-1346~~ 3154.78  
OTHER ~~240-1360~~  
1/8/25

Thank You For Your Business

PAGE TOTAL	ORDER TOTAL	PAGE TOTAL	BOTTLES ORDER TOTAL	WINE GALLONS	16.64	TOTAL # BTLS:	238	YTD TOTAL DISCOUNT:	949.40
	21	9	21	LIQUOR GALLONS	28.46	CUSTOMER	EAGLE LANDING GOLF CLUB	PAGE	GROSS TOTAL
				BEER GALLONS					TOTAL DISCOUNT
CARTON	DRIVER	LOADED				INVOICE NO.	3	4,598.54	880.28
21						CUSTOMER NO.			3,718.26

Buyer represents that it is authorized under applicable law to purchase all the products delivered in this invoice and that all such products were ordered by it and have been received without any damage, unless noted otherwise on invoice. SELLER EXPRESSLY DISCLAIMS ANY WARRANTY, INCLUDING MERCHANTABILITY OR FITNESS FOR A PARTICULAR PURPOSE, INCLUDING DAMAGES CONSEQUENTIAL, PUNITIVE, THERE OF OR OTHER.

*C. Buss*

CHAMPION BRANDS INC ACH  
 PO BOX 56260  
 JACKSONVILLE FL 32241  
 1-904-268-1220 2601463

**OT 01030**  
 SOUTH VILLAGE COMMUNITY D  
 EAGLE LANDING GOLF CLUB  
 3989 EAGLE LANDING PKWAY  
 ORANGE PARK FL 32065  
 2001434

LOAD	SALESPERSON	ACCOUNT NO.	INVOICE DATE	INVOICE NO.
747	HUNTER L-001	23384	1/09/25	03527015

FINTECH 1904 291-5600

MISC PRODUCTS COASTER SLEEVE 32 99027 2 50 80.00  
 Hunter Labbie will deliver

*[Handwritten signature]*  
 1/14/25  
 Paid 1/9/25  
 240-7450

32 MISC 80.00 MISC\* 80.00 CONTENT\*  
 0 CASE 00 BEER\* 00 DEPOSIT\*  
 0 KEGS 00 SODAS

\$ 80.00 03527015

DESCRIPTION	CODE	QTY	PRICE	AMOUNT
LER 1/2	99152	30	00	
LER 1/4	99154	30	00	
LER 1/8	99156	30	00	
LY KEGS	99252	30	00	
ITON 1/2	99552	30	00	
ITON 1/4	99554	30	00	
FT 1/2	99356	30	00	
FT 1/4	99256	30	00	
NNESS RET	99352	30	00	

DESCRIPTION	CODE	QTY	PRICE	AMOUNT
IMPORT RET	99675	30	00	
MICROSTAR RET	99260	30	00	
WVEN RETURNS	99652	30	00	

SECTION 561.42, FLORIDA STATUTES, AND RULE 61A-1.010, PRODUCTS DAMAGED BY VENDORS SHALL NOT BE RETURNED TO THE DISTRIBUTOR FOR CREDIT OR EXCHANGE AND WILL BE THE VENDOR'S LIABILITY. VENDORS SHALL NOTIFY DISTRIBUTORS OF DAMAGED PRODUCTS RECEIVED FROM THE DISTRIBUTOR WITHIN 10 DAYS AFTER DELIVERY IN ORDER TO OBTAIN A CREDIT OR EXCHANGE. A TRANSACTION RECORD OF ALL EXCHANGES MUST BE MADE BY THE DISTRIBUTOR.

TOTAL CHARGES ▶ 80.00

LESS TOTAL CREDITS ▶

PAYMENT  
 CASH  
 CHECK

NET AMOUNT DUE ▶



EAGLE LANDING GOLF  
3989 EAGLE LANDING PKWY  
ORANGE PARK FL 32065-2641

Page 1 of 2  
Account Number 904 291-6097 141 0567  
Billing Date Jan 1, 2025

Web Site att.com

# Monthly Statement

Connect more & save  
Expand your options. Go all in with our best wireless plans and hyper-fast internet for powerful, unlimited connections and savings that last. Call 844.580.1740 today.

## Bill-At-A-Glance

Previous Bill	247.63
Payment Received 12-19 Thank You!	247.63CR
Adjustments	.00
Balance	.00
Current Charges	247.67
<b>Amount to be Debited</b>	<b>\$247.67</b>
Debiting Bank Account on	Jan 18, 2025

## Plans and Services

### Promotions and Discounts

Item No.	Description	
1.	Discount for Business Local Calling for Bill Period Jan 1, 2025 EESH1KTF8.	170.00CR

### Monthly Service - Jan 1 thru Jan 31

2.	<b>Bus Local Call Unlimited A</b>	<b>350.00</b>
	Business Line	
	Three-Way Calling	
	30 Code Speed Calling	
	Call Forwarding	
	Call Waiting	
	Repeat Dialing	
	Call Return	
	Call Blocking	
	Caller-ID Name-Number Delivery	
	Anonymous Call Blocking	

### Company Fees and Surcharges

Item No.	Description	Quantity	
3.	Cost Assessment Charge	1	7.50
4.	Federal Universal Service Fee	1	2.32
5.	Federal Subscriber Line Charge	1	6.50
<b>Total Company Fees and Surcharges</b>			<b>16.32</b>

### Government Fees and Taxes

Item No.	Description	Quantity	
6.	Federal Excise Tax		5.60
7.	FL - State Communications Tax		14.90
8.	FL - Local Communications Tax		13.20
9.	Telecommunications Access System Act Surcharge	1	.08
10.	Emergency 911 Service	1	.40
<b>Total Government Fees and Taxes</b>			<b>33.88</b>

**Total Plans and Services 230.20**

## AT&T Long Distance Service

### Monthly Service

Charges for 904 291-6097		
Type of Service	Period	
11. All For Less Unlimited 1 Plan Monthly Fee	12/11-01/10	12.00

## Billing Summary

Online: att.com/myatt	Page	
<b>Plans and Services</b>	1	230.20
1 800-321-2000		
PIN: 2303		
Repair Service:		
1 866 620-6900		
<b>AT&amp;T Long Distance Service</b>	1	17.47
1 800 321-2000		
<b>Total Current Charges</b>		<b>247.67</b>

520-7835  
[Signature]  
1/14/25

## News You Can Use Summary

- PREVENT DISCONNECT
  - FEES AND SURCHARGES
  - BUSINESS RATE CHANGE
  - CARRIER INFORMATION
  - EXPRESS TICKETING
  - COST ASSESSMENT CHRG
- See "News You Can Use" for additional information.





Champion Brands Inc.  
 PO BOX 56260  
 Jacksonville, FL 32241  
 (904)-268-1220  
 Tue Jan 14, 2025 3:53 PM

ACH

Account: 23384  
 SOUTH VILLAGE COMMUNITY D  
 EAGLE LANDING GOLF CLUB  
 3989 EAGLE LANDING PKWAY  
 ORANGE PARK, FL 32065  
 (904) 291-5600

Invoice#: 3529041 PO#:   
 License : 2001434 Expires N/A  
 Load : 201  
 Terms : FINTECH  
 Driver : 01 - T. FLICK  
 Salesrep: B01 - HUNTER LABBIE

ITEM#	QTY	DESCRIPTION	U.P.C.	Disc	D.PRICE	DEP	EXT
05176	4	COORS LIGHT	071990301064		3.25	26.25	0.00 105.00
		COORS LIGHT ALUMINUM 24/16 CAN					
07702	1	HEINEKEN	072890000200		0.00	36.80	0.00 36.80
		HEINEKEN 2/12/12 CAN					
85151	1	INTUITION I-10	850501003051		0.00	38.35	0.00 38.35
		INTUITION I-10 IPA 4/6/12 CAN					
48208	1	LEIN SUM SHAND	034100516093		0.00	38.35	0.00 38.35
		LEINENKUGEL SUMMER SHANDY #2/12/12 CANS					
57274	6	LITE	034100003760		3.25	26.25	0.00 157.50
		LITE ALUMINUM 24/16 CAN					
56003	1	MAS+	810161620029		0.00	25.00	0.00 25.00
		MAS+ BY MESSI MIAMI PUNCH 12/16.9 BOTTLE					
90035	1	RB ENERGY DRIN	611269991000		0.00	41.50	0.00 41.50
		RED BULL ENERGY DRINK 8OZ SINGLES					

Beer: 13 + 0 Kegs \$376.00  
 Wine & Liq: 0 \$0.00  
 Soft Drink: 2 \$66.50  
 Misc: 0 \$0.00  
 Credits: 0 \$0.00

*Rec'd HJ*  
*1/14/25*

*611  
 1/21/25*

*OTHER*  
~~240-1360~~ = ~~66.50~~  
 000  
 66.50  
 -----  
 000  
 240-1342  
 000  
 376.00

Total Selling Units:	54
Total Sales	475.00
Total Discount	-32.50
-----	
Total Content	442.50
Total Deposit	0.00
Total Credits	0.00
Over/Short	0.00
-----	
Invoice Total	442.50

I ACCEPT THIS PRODUCT DELIVERY IN SALEABLE CONDITION.  
 YOUR SIGNATURE IS ACCEPTANCE OF ALL ABOVE ITEMS. PLEASE CHECK CAREFULLY.  
 Thank you!

Customer Signature: \_\_\_\_\_ Driver Signature: \_\_\_\_\_



3601 Resent Blvd.  
 Jacksonville, FL 322  
 (904) 645-0283  
 NFSales.net

EAGLE LANDING GOLF C  
 3589 EAGLE LANDING P  
 ORANGE PARK, FL 3206  
 BEV2001434  
 Brooke Simard

Fintech

Date	Invoice	LeadSheet	Vendor	PO Num		
01/14/2025	4090281	271444		20757262		
Route	Customer	Deliverer	Salesman			
1504 TUES	101152	AMATTHEWS				
ID	QTY	PRODUCT	PRICE	DISC	NET	TOTAL
1805	(2)	EMPTY 1/2 BBL	\$30.00		\$30.00	(\$60.00)
322	1	ULTRA 1/2	\$148.30	\$30.00	\$118.30	\$178.30
Pallet-2548446						
53504	2	BUD LT 2/12 16OZ TWST AL B	\$30.60		\$30.60	\$61.20
11584	1	BUD 2/12 16OZ TWST AL B	\$30.60		\$30.60	\$30.60
727	2	CORONA EXTRA 2/12 B	\$32.00		\$32.00	\$65.60
76378	6	ULTRA 2/12 16OZ AL TW	\$35.00		\$35.00	\$214.80
6	10	BEER 47.0000 Gallons	\$39.00	\$0.00		

*[Handwritten signature]*  
 1/14/25

Total \$490.50  
 Charges \$550.50  
 Credits \$60.00  
 Total \$490.50

*Rec'd 1/14/25*  
 000  
 210-1342  
 B088  
 \$490.50

ACH

Champion Brands Inc.  
PO BOX 56260  
Jacksonville, FL 32241  
(904)-268-1220  
Tue Jan 14, 2025 3:44 PM

Account: 23384  
SOUTH VILLAGE COMMUNITY D  
EAGLE LANDING GOLF CLUB  
3989 EAGLE LANDING PKWAY  
ORANGE PARK, FL 32065  
(904) 291-5600

Invoice#: 3529042 PO#:   
License : 2001434 Expires N/A  
Load : 201  
Terms : FINTECH  
Driver : 01 - T. FLICK  
Salesrep: B01 - HUNTER LABBIE

ITEM#	QTY	DESCRIPTION	U.P.C.	Disc	D.PRICE	DEP	EXT
57152	1	LITE	034100005344				
		LITE 1/2 BBL 15.5 GAL		11.00	123.00	30.00	153.00
09552	0	SAM LAGER	087692109990				
		SAM ADAMS LAGER 1/2 BBL 15.5 GAL		0.00	176.00	30.00	0.00
		Out of Stock					
19462	1	SN LITTLE THIN	000000000000				
		SIERRA HAZY LITTLE THING 1/2 BBL 15.5 GAL		0.00	185.00	30.00	215.00
99152	-1	MILLER RETURNS	000000000000				
		MILLER EMPTY 1/2 BBL		0.00	0.00	30.00	-30.00
99652	-1	YUENGLING RETS	000000000000				
		YUENGLING EMPTY 1/2 BBL		0.00	0.00	30.00	-30.00

Beer: 0 + 2 Kegs \$368.00  
 Wine & Liq: 0 \$0.00  
 Soft Drink: 0 \$0.00  
 Misc: 0 \$0.00  
 Credits: -2 -\$60.00

*[Handwritten signature]*  
 1/14/25

*Rec'd SF 1/14/25*  
 000 ~~240~~ 1342  
 BEER  
 1308.00

Total Selling Units:	0
Total Sales	319.00
Total Discount	-11.00
Total Content	308.00
Total Deposit	60.00
Total Credits	-60.00
Over/Short	0.00
Invoice Total	308.00

I ACCEPT THIS PRODUCT DELIVERY IN SALEABLE CONDITION.  
 YOUR SIGNATURE IS ACCEPTANCE OF ALL ABOVE ITEMS. PLEASE CHECK CAREFULLY.  
 Thank you!

Customer Signature:

Driver Signature:

*[Handwritten signature: FLICK]*

Champion Brands Inc.  
 PO BOX 56260  
 Jacksonville, FL 32241  
 (904)-268-1220  
 Tue Jan 14, 2025 3:53 PM

Account: 23384      Invoice#: 3529039      PO#:      License : 2001434 Expires N/A  
 SOUTH VILLAGE COMMUNITY D      Load : 201  
 EAGLE LANDING GOLF CLUB      Terms : FINTECH  
 3989 EAGLE LANDING PKWAY      Driver : 01 - T. FLICK  
 ORANGE PARK, FL 32065      Salesrep: 601 - HUNTER LABBIE  
 (904) 291-5600

*6*  
*AP*  
*1/14/25*

ITEM#	QTY	DESCRIPTION	U.P.C.	Disc	D.PRICE	DEP	EXT
896004	1	SUN CRUISER	087692020318	15.70	39.60	0.00	39.60
		24/12 ICED TEA	24/12 CAN				
896003	0	SUN CRUISER	087692020301	0.00	36.00	0.00	0.00
		3/8/12 VARIETY	3/8/12 CAN				
		Out of Stock					
600002	1	WATERBIRD	860005649518	0.00	49.50	0.00	49.50
		6/4/12 RANCH WATER	WB RANCH 6/4/12, CAN				

Beer: 0 + 0 Kegs      \$0.00  
 Wine & Liq: 2      \$89.10  
 Soft Drink: 0      \$0.00  
 Misc: 0      \$0.00  
 Credits: 0      \$0.00

*Rev St*  
*1/14/25*  
 000  
~~240-1346~~  
 89.70  
 LIQUOR

Total Selling Units:	7
Total Sales	104.80
Total Discount	-15.70
Total Content	89.10
Total Deposit	0.00
Total Credits	0.00
Over/Short	0.00
Invoice Total	89.10

I ACCEPT THIS PRODUCT DELIVERY IN SALEABLE CONDITION.  
 YOUR SIGNATURE IS ACCEPTANCE OF ALL ABOVE ITEMS. PLEASE CHECK CAREFULLY.  
 Thank you!

Customer Signature:      Driver Signature:

*FLICK*

SOUTHERN GLAZER'S OF FL  
4440 OLD TAMPA HIGHWAY  
LAKELAND, FLORIDA  
33811

REMIT TO:  
SOUTHERN GLAZER'S OF FL  
P.O. BOX 947921  
ATLANTA, GA 30394-7921  
1-800-375-9555



INVOICE NUMBER	3632740
ACCOUNT NUMBER	85510
ROUTE	516 STOP 6

EAGLE LANDING GOLF CLUB  
3989 EAGLE LANDING PARKWAY  
ORANGE PARK FL 32065

EAGLE LANDING GOLF CLUB  
3989 EAGLE LANDING PARKWAY  
ORANGE PARK FL 32065

**C.O.D.**

S  
H  
I  
P  
T  
O

DUPLICATE

C O D C.O.D. FINTECH  
FINTECH

PAGE 1 OF 2  
1500 3 14

LAKELAND-NIGHT BILL

LICENSE NUMBER	SALES PERSON	DELVRY INSTRUCTIONS:	PHONE NUMBER	INVOICE DATE
20-01434	186	P.O.#:	904-291-5600	1/15/2025

LOC	CASES	STLS	SIZE	DESCRIPTION	PACK	W-LOC.	B-DC.	PRODUCT CODE	NET BTL PRICE	UNIT PRICE	DIV CDE	UNIT DISCOUNT	NET AMOUNT
	1		50ML	CROWN ROYAL ASST(RAPP/PCH)10P PET	6			623245	15.00	90.00	001		90.00
	1		750ML	DON JULIO TEQ BLANCO 80	6			971835	43.50	277.02	001	16.02	261.00
	1		750ML	JOSH CELLARS PROSECCO	12			925073	11.25	189.00	002	54.00	135.00
	10		240ML	OWENS MIXERS TRANSFUSION CN4P WRAP	6			653680	4.76	30.00	002	1.44	285.60
	4		240ML	OWENS MIXERS TRANSFUSION CN4P WRAP	6			653680		30.00	002	30.00	
	1		750ML	PATRON TEQ SILVER 80 BAR	6			109101	40.00	250.50	080	10.50	240.00
	1		750ML	SUTTER HOME MOSCATO(SC)	12			513862	4.40	81.00	003	28.20	52.80
	1		1.0L	TIJUANA TEQUILA WHITE 80	12			376513	9.00	144.00	002	36.00	108.00
	1		750ML	WOODBIDGE CHARD SP COL(SC)	12			913777	4.00	87.00	007	39.00	48.00
	2		750ML	WOODBIDGE PINOT GRIGIO SP COL(SC)	12			915650	4.00	87.00	007	39.00	95.00
	1		750ML	WOODBIDGE PINOT NOIR	12			133770	4.00	90.00	007	42.00	48.00
	1		32 Z	ZING ZANG BLOODY MARY MIX PET	12			972007	4.00	72.00	003	24.00	48.00
	1		1.0L	ABSOLUT VOD VANILIA 76	6			572834	33.66	33.66	005		33.66

C  
O  
D

Thank You For Your Business

PAGE TOTAL	CASES ORDER TOTAL	BOTTLES ORDER TOTAL	WINE GALLONS	LIQUOR GALLONS	BEER GALLONS	CUSTOMER	PAGE	GROSS TOTAL	TOTAL DISCOUNT	PAY THIS AMOUNT
25	25	1	13			EAGLE LANDING GOLF CLUB	1			** CONT **
CARTON	DRIVER	LOADED	Buyer represents: that it is authorized under applicable law to purchase all the products delivered in this invoice; and, that all such products were ordered by Buyer and have been received without any storage, unless noted on invoice at			INVOICE NO.	CUSTOMER NO.	NET AMOUNT	DUE DATE	

If net price according to trade terms, net to dealer price, market discounts, export taxes or discounts in appropriate amounts, and if other details, please refer to copy of contract and agreement. All amounts shown are subject to the terms of the contract and agreement. Please refer to the terms of the contract and agreement.



ACH

SOUTHERN GLAZER'S OF FL  
4440 OLD TAMPA HIGHWAY  
LAKELAND, FLORIDA  
33811

REMIT TO:
SOUTHERN GLAZER'S OF FL P.O. BOX 947921 ATLANTA, GA 30394-7921 1-888-375-9555



INVOICE NUMBER	3532740		
ACCOUNT NUMBER	85510		
ROUTE	516	STOP	6

69  
S EAGLE LANDING GOLF CLUB  
O 3989 EAGLE LANDING PARKWAY  
L ORANGE PARK FL 32065  
D

S EAGLE LANDING GOLF CLUB  
H 3989 EAGLE LANDING PARKWAY  
I ORANGE PARK FL 32065  
P

T O  
**C.O.D.** H

DUPLICATE

C O D C.O.D. FINTECH  
FINTECH

PAGE 2 OF 2  
1500 3 14

LAKELAND-NIGHT BILL

LICENSE NUMBER	SALES PERSON	DELIVERY INSTRUCTIONS:	PHONE NUMBER	INVOICE DATE
20-01434	136	P.O.#:	904-291-5600	1/15/2025

LOC	CASES	BTL'S	SIZE	DESCRIPTION	PACK	W.LOC.	D.LOC.	PRODUCT CODE	NET BTL PRICE	UNIT PRICE	DIV CDE	UNIT DISCOUNT	NET AMOUNT
		1	1.0L	ABSOLUT VOD WATERMELON 76	6			988223	33.66	33.66	005		33.66
		1	750ML	ANGELS ENVY BBN 86.6	6			404725	45.10	45.10	080		45.10
		1	1.0L	BACARDI RUM SUPERIOR WHITE 80	12			28728	20.12	20.12	080		20.12
		2	1.0L	CROWN ROYAL PEACH 70(BAR)	12			631475	40.45	41.70	001	1.25	80.90
		2	1.0L	CROWN ROYAL REGAL APPLE 70 BAR	12			631461	40.45	41.70	001	1.25	80.90
		1	1.0L	DEKUYPER PUCKER WATERMELON SCHN 30	12		20513	49357	14.23	14.23	003		14.23
		1	45 Z	FILTHY BLACK CHERRY TIN CAN	6			547868	38.50	38.50	001		38.50
		1	1.0L	HENNESSY COGNAC VS 80	12			344101	57.20	57.20	001		57.20
		1	1.0L	MALIBU RUM COCONUT 42	12		20262	33451	23.78	23.78	005		23.78
		1	1.0L	TANQUERAY GIN 94.6	12		21523	278078	32.45	32.45	001		32.45

*Rec'd H 1/15/25*

**C  
O  
D**

WINE ~~240~~<sup>000</sup> 1344-379.80  
OTHER ~~240~~<sup>000</sup> 1360-372.10  
LOCAL ~~240~~<sup>000</sup> 1346-1121.00

Thank You For Your Business

PAGE TOTAL	CASES ORDER TOTAL	BOTTLES ORDER TOTAL	WINE GALLONS	LIQUOR GALLONS	BEER GALLONS	CUSTOMER	PAGE	GROSS TOTAL	TOTAL DISCOUNT	PAY THIS AMOUNT
	25	12	13	9.44		EAGLE LANDING GOLF CLUB	2	2,340.02	467.12	1,872.90
CARTON	DRIVER	LOADED	INVOICE NO.			CUSTOMER NO.	NET AMOUNT	DATE		

Buyer represents that it is authorized under applicable law to purchase all the products delivered in this invoice and that all such products were ordered by buyer and have been received without any damage, unless noted on invoice at time of delivery. Seller's responsibility ends upon delivery of goods to buyer.

If not paid according to terms, seller may resell the goods at a discount, without notice or obligation to account therefor, and if any specific account is kept of subsequent accountings therefor, payment of check or draft in the face of this invoice shall constitute an acknowledgment of the validity of the invoice and the amount thereof.

CHAMPION BRANDS INC ACH X  
 PO BOX 56260  
 JACKSONVILLE FL 32241  
 1-904-268-1220 2601463

**SALES TO**  
 SOUTH VILLAGE COMMUNITY D  
 EAGLE LANDING GOLF CLUB  
 3989 EAGLE LANDING PKWAY  
 ORANGE PARK FL 32065  
 2001434

SM PHONE#

LOAD	SALESPERSON	ACCOUNT NO.	INVOICE DATE	INVOICE NO.
747	HUNTER L-801	23384	1/16/25	03532406

FINTECH 1904 291-5600

100 LAGER SAM ADAMS LAGER 176 BBL 2 09554 30.00 77.00 214.00  
 5.167 GAL  
 Hunter Labbie will deliver

*NG out 1-16-25*

*[Handwritten signature]*  
 1/16/25

*Rec'd 1/16/25  
 240.7450  
 \$214.00*

*[Handwritten signature]*

0 MISC .00 MISC#  
 0 CASE 214.00 BEER#  
 2 KEGS .00 SODA#

154.00 CONTENTS 12.00 BEER# 60.00 BEER#

03532406 TOTAL CHARGES 214.00

DESCRIPTION	CODE	QTY	PRICE	AMOUNT	DESCRIPTION	CODE	QTY	PRICE	AMOUNT
LLER 172	97152		30.00		IMPORT RET	97575		30.00	
LLER 174	97154		30.00		MICROSTAR RET	97260		30.00	
LLER 176	97156		30.00		VVEN RETURNS	97852		30.00	
LLY KEGS	97252		30.00						
STON 172	97352		30.00						
STON 176	97356		30.00						
AFT 172	97358		30.00						
AFT 176	97359		30.00						
INNESS RET	97352		30.00						

SECTION 561.42, FLORIDA STATUTES, AND RULE 61A-1.010, PRODUCTS DAMAGED BY VENDORS SHALL NOT BE RETURNED TO THE DISTRIBUTOR FOR CREDIT OR EXCHANGE AND WILL BE THE VENDOR'S LIABILITY. VENDORS SHALL NOTIFY DISTRIBUTORS OF DAMAGED PRODUCTS RECEIVED FROM THE DISTRIBUTOR WITHIN 10 DAYS AFTER DELIVERY IN ORDER TO OBTAIN A CREDIT OR EXCHANGE. A TRANSACTION RECORD OF ALL EXCHANGES MUST BE MADE BY THE DISTRIBUTOR.

LESS TOTAL CREDITS  
 PAYMENT  
 CASH  
 CHECK  
 NET AMOUNT DUE

CHAMPION BRANDS INC ACH X  
 PO BOX 56260  
 JACKSONVILLE FL 32241  
 1-904-268-1220 2601463

SM PHONE#

SOUTH VILLAGE COMMUNITY D  
 EAGLE LANDING GOLF CLUB  
 3989 EAGLE LANDING PKWAY  
 ORANGE PARK FL 32065  
 2001434

LOAD	SALESPERSON	ACCOUNT NO.	INVOICE DATE	INVOICE NO.
747	HUNTER L-B01	23384	1/17/25	03533642

FINTECH

1904 291-5600

17E LITE 1/2 BBL 15.5 GAL  
 unter Labbie will deliver

1 57152

30 00134.00 164.00

*[Handwritten signature]*  
 1/17/25

*[Handwritten signature]*  
 1-17-25

*[Handwritten signature]*  
 New H 1/17/25

~~240-1342~~ Bossa  
 000

9164.00

134.00 CONTENTS# 15.50 GALLONS

0 MISC .00 MISC# 30.00 DEPOSIT#  
 0 CASE 164.00 BEER#  
 1 KEGS .00 SODA#

03533642 TOTAL CHARGES 164.00

DESCRIPTION	CODE	QTY	PRICE	AMOUNT	DESCRIPTION	CODE	QTY	PRICE	AMOUNT
CLER 1/2	99152		30.00		IMPORT RET	99575		30.00	
CLER 1/4	99154		30.00		MICROSTAR RET	99260		30.00	
CLER 1/6	99156		30.00		YUEN RETURNS	99652		30.00	
CLY KEGS	99252		30.00						
STON 1/2	99552		30.00						
STON 1/6	99555		30.00						
AFT 1/2	99356		30.00						
AFT 1/6	99256		30.00						
INNESS RET	99352		30.00						

SECTION 561.42, FLORIDA STATUTES, AND RULE 81A-1.010, PRODUCTS DAMAGED BY VENDORS SHALL NOT BE RETURNED TO THE DISTRIBUTOR FOR CREDIT OR EXCHANGE AND WILL BE THE VENDOR'S LIABILITY. VENDORS SHALL NOTIFY DISTRIBUTORS OF DAMAGED PRODUCTS RECEIVED FROM THE DISTRIBUTOR WITHIN 10 DAYS AFTER DELIVERY IN ORDER TO OBTAIN A CREDIT OR EXCHANGE. A TRANSACTION RECORD OF ALL EXCHANGES MUST BE MADE BY THE DISTRIBUTOR.

LESS TOTAL CREDITS  
 PAYMENT  
 CASH  
 CHECK  
 NET AMOUNT DUE





Account Number  
8495 74 144 1037847

Billing Date  
Jan 05, 2025

Services From  
Jan 15, 2025 to Feb 14, 2025

Page  
1 of 4

# Hello Golf Course Eagle Landing,

Thanks for choosing Comcast Business.

## Your bill at a glance

For 3989 EAGLE LANDING PKWY, ORANGE PARK, FL, 32065-2641

Previous balance		\$699.06
One-time EFT Payment - thank you	Jan 02	-\$699.06
<b>Balance forward</b>		<b>\$0.00</b>
Regular monthly charges	Page 3	\$695.75
One-time charges	Page 3	\$3.95
Taxes, fees and other charges	Page 3	\$37.89
<b>New charges</b>		<b>\$737.59</b>

**Amount due Jan 26, 2025 \$737.59**

## Your bill explained

- Regular monthly charges have increased by \$31.10 as a result of service change(s) made to Internet services, Voice services, TV services and other regular monthly charges.
- Your one-time charges are \$3.95 due to Paper Statement Fee charge(s).
- This page gives you a quick summary of your monthly bill. A detailed breakdown of your charges begins on page 3.



### Need help?

Visit [business.comcast.com/help](https://business.comcast.com/help) or see page 2 for other ways to contact us.

*504-7810*  
*[Signature]*  
*1/21/25*

Detach the bottom portion of this bill and enclose with your payment

Please write your account number on your check or money order

Do not include correspondence with payment



1100 NORTHPOINT PKWY W PALM  
BCH FL 33407-1937  
06530010 NO FIP 05 20250105 NNNNNNNY 0000109 0001

EAGLE LANDING GOLF COURSE  
3989 EAGLE LANDING PKWY  
ORANGE PARK FL 32065-2641

Account number **8495 74 144 1037847**  
 Payment due **Jan 26, 2025**  
**Please pay \$737.59**  
 Amount enclosed \$

Make checks payable to Comcast  
Do not send cash



Send payment to  
COMCAST  
PO BOX 71211  
CHARLOTTE, NC 28272-1211

Regular monthly charges		\$695.75
<b>Comcast Business</b>		<b>\$679.75</b>
<b>TV services</b>		<b>\$115.00</b>
TV Basic	\$65.95	
Business Video		
TV Adapter	\$11.95	
Broadcast TV Fee	\$37.10	
<b>Internet services</b>		<b>\$469.90</b>
Business Internet 1g	\$499.95	
Service Discount	-\$60.00	
Static IP - 1	\$29.95	
<b>Voice services</b>		<b>\$94.85</b>
Basic Voice Line	\$24.95	
Business Voice		
Mobility Voice Line	\$44.95	
Business Voice		
Equipment Fee	\$24.95	
Voice		
<b>Service fees</b>		<b>\$16.00</b>
Directory Listing Management	\$8.00	
Fee		
Voice Network Investment	\$8.00	
<b>One-time charges</b>		<b>\$3.95</b>
<b>Other charges</b>		<b>\$3.95</b>
Paper Statement Fee	Jan 05	\$3.95
<b>Taxes, fees and other charges</b>		<b>\$37.89</b>
<b>Other charges</b>		<b>\$6.05</b>
Federal Universal Service Fund	\$2.16	
Regulatory Cost Recovery	\$3.89	
<b>Taxes &amp; government fees</b>		<b>\$31.84</b>
Sales Tax	\$2.77	
State Communications Services	\$14.45	
Tax		

What's included?



**Internet:** Fast, reliable internet on our Gig-speed network



**TV:** Keep your employees informed and customers entertained



**Voice Numbers:** (904)375-9741, (904)375-8900

Visit [business.comcast.com/myaccount](https://business.comcast.com/myaccount) for more details.

You've saved \$60.00 this month with your service discount.



EAGLE LANDING GOLF CLUB  
 CGMP MANAGERS 11 LLC  
 3989 EAGLE LANDING PKWY  
 ORANGE PARK FL 32065  
 PH: 904-291-5600



6031 Madison Avenue  
 Tampa, FL 33619  
 Phone: (813) 672-6161

FED# FL-P-21520  
 IMP# FL-I-21446  
 STATE#KLD3900175

ACH



CUSTOMER #	INVOICE DATE	INVOICE #
700026767	1/21/2025	119677811

All requests for returns must be in writing within 10 days of delivery.

\*\* INVOICE \*\*

ROUTE	STOP	SPECIAL INSTRUCTIONS				PURCHASE ORDER #	REP	DUE DATE	CREDIT TERMS						
2330	39	DELIVER 7 AM - 6 PM.					0792	02/03/25	EFT NET 10 days						
ITEM #	#CASE	#BTL	SIZE	DESCRIPTION	UPC	PACK	UNIT	DISCOUNT	NET CASE	NET BOTTLE	EXTENDED AMOUNT				
9611931		30	50ML	JACK DANIELS BLK FET WRAP 12/10PK 50ML		120	2.39	0.20		2.19	65.70				
9127710		2	1L	JACK DANIELS TN HONEY 70 1L		12	36.70	0.75		35.95	71.90				
9006222		3	1L	MR BOSTON SCHNPS BUTTERSOTCH 1L		12	6.95			6.95	20.85				
9220188	1		50ML	FIREBALL CINN WHSKY PET 12/10PK 50ML		120	73.20		73.20	0.61	73.20				
9423436	1		355ML	HIGH NOON CKTL PEACH CAN 6/4PK 355ML		24	81.00	41.40	39.60	1.65	39.60				
9405456	2		355ML	HIGH NOON SN SP CAN 2/12 355ML		24	72.00	32.40	39.60	1.65	79.20				
9001700	1		750ML	MILAGRO TEQ SLVR 6B 750ML		6	182.40	29.40	153.00	25.50	153.00				
				Delivery Charge							12.50				
<p><i>Rec'd 1/21/25</i></p> <p><i>LIQUOR <del>240.1346</del> - \$515.95</i></p> <p><i>000</i></p> <p><i>[Signature]</i></p>															
To offset rising operational costs and maintain the highest level of service, BBG-FL will implement minor split case and delivery fee adjustments effective 1/21/25.						Customer Signature: <i>[Signature]</i>									
11.244						Thank you for your order. We appreciate your business.									
Cases		Bottles		Empty Keg Returns		Access PAY NOW, Breakthru's online payment portal to manage invoice payments.		License #		Sales Tax #		Discount		Total Amount Due	
ZOR		5		35		233		2001434 110G		999999		143.10		515.95	

Facebook [www.facebook.com/breakthrubevFL](http://www.facebook.com/breakthrubevFL)  
 Twitter @breakthrubevFL  
 Instagram [www.instagram.com/breakthrubevFL](http://www.instagram.com/breakthrubevFL)

Visit [www.breakthrubev.com](http://www.breakthrubev.com)  
 to register your account today!



STATE BEVERAGE LAWS REQUIRE FULL PAYMENT OF THIS INVOICE ON OR BEFORE DUE DATE SHOWN. PAYMENTS MADE AFTER DUE DATE, RETURNED PAYMENTS AND PAST DUE INVOICES WILL RESULT IN LOST DISCOUNTS AND THE GROSS TOTAL WILL BE DUE. CUSTOMERS RESPONSIBLE FOR ALL COSTS OF COLLECTION. IN THE EVENT SUIT IS FILED TO RECOVER UNPAID BALANCE, CUSTOMERS RESPONSIBLE FOR ALL COSTS, INTEREST AND REASONABLE ATTORNEY FEES.





3601 Regent Blvd.

Jacksonville, FL 322  
 (904) 645-0283  
 NFSales.net

EAGLE LANDING GOLF C  
 3989 EAGLE LANDING P

ORANGE PARK, FL 3206  
 REV2001434  
 Brooke Steward

Stacy McClellan

Fintech

*Handwritten signature in blue ink, possibly reading 'Stacy McClellan'.*

Date	Invoice	LoadSheet	Vendor	PO Num			
01/21/2025	4095173	291632		20949473			
Route	Customer	Deliverm	Salesman				
1504 TUES	101152	AMTTHENS	API_11825				
ID	QTY	PRODUCT	PRICE	DEP	DISC	NET	TOTAL
1895	(1)	EMPTY 1/2 BBL	\$30.00			\$30.00	(\$30.00)
322	2	ULTRA 1/2	\$148.30	\$30.00		\$118.30	\$356.60
720	1	CORONA EXTRA 2/12 C	\$32.80			\$32.80	\$32.80
9283	1	STELLA 4/6 12oz C	\$36.05			\$36.05	\$36.05
76378	5	ULTRA 2/12 16OZ AL TW	\$35.80			\$179.00	\$179.00
5	8	BEER 50.5000 Gallons	\$60.00	\$0.00			

Total \$574.45  
 Charges \$604.45  
 Credits \$30.00  
 Total \$574.45

*Handwritten signature and date: # 1/21/24*

*Handwritten text: 240-1342 Beer \$574.45*

000

ACH

Champion Brands Inc.  
PO BOX 56260  
Jacksonville, FL 32241  
(904)-268-1220  
Tue Jan 21, 2025 2:41 PM

Account: 23384      Invoice#: 3533736      PO#:  
SOUTH VILLAGE COMMUNITY D      License : 2001434 Expires N/A  
EAGLE LANDING GOLF CLUB      Load : 281  
3989 EAGLE LANDING PKWAY      Terms : FINTECH  
ORANGE PARK, FL 32065      Driver : 81 - Z. GONZALES  
(904) 291-5600      Salesrep: 801 - HUNTER LABBIE

ITEM#	QTY	DESCRIPTION	U.P.C.	Disc	D.PRICE	DEP	EXT
896004	1	SUN CRUISER 24/12 ICED TEA	087692020318 24/12 CAN	15.70	39.60	0.00	39.60
896003	1	SUN CRUISER 3/8/12 VARIETY	087692020301 3/8/12 CAN	13.50	36.00	0.00	36.00
896003	0	SUN CRUISER 3/8/12 VARIETY	087692020301 3/8/12 CAN	0.00	36.00	0.00	0.00
		Out of Stock					
600006	1	WATERBIRD 6/4/12 VODKA TRANSFUS MB VODKA TRAMS 6/4	860005649570	0.00	49.45	0.00	49.45

Beer: 0 + 0 Kegs      \$0.00  
Wine & Liq: 3      \$125.05  
Soft Drink: 0      \$0.00  
Misc: 0      \$0.00  
Credits: 0      \$0.00

Total Selling Units:	10
Total Sales	154.25
Total Discount	-29.20
-----	
Total Content	125.05
Total Deposit	0.00
Total Credits	0.00
Over/Short	0.00
-----	
Invoice Total	125.05

I ACCEPT THIS PRODUCT DELIVERY IN SALEABLE CONDITION.  
YOUR SIGNATURE IS ACCEPTANCE OF ALL ABOVE ITEMS. PLEASE CHECK CAREFULLY.  
Thank you!

Customer Signature:

Driver Signature:

~~240~~-1344 Liquor  
000  
\$ 125.05  
1/21/24

ACH

Champion Brands Inc.  
PO BOX 56260  
Jacksonville, FL 32241  
(904)-268-1220  
Tue Jan 21, 2025 2:58 PM

Account: 23394      Invoice#: 3533738      PO#:        
SOUTH VILLAGE COMMUNITY D      License : 2001434 Expires N/A  
EAGLE LANDING GOLF CLUB      Load : 281  
3989 EAGLE LANDING PKWAY      Terms : FINTECH  
ORANGE PARK, FL 32065      Driver : 81 - Z. GONZALES  
(904) 291-5600      Salesrep: B01 - HUNTER LABBIE

ITEM#	QTY	DESCRIPTION	U.P.C.	Disc	D.PRICE	DEP	EXT
57152	2	LITE	034100005344	11.00	123.00	30.00	306.00
		LITE 1/2 BBL 15.5 GAL					
09398	0	SAM SEASONAL	087692019992	0.00	176.00	30.00	0.00
		SAM ADAMS COLD SNAP 1/2 BBL 15.5 GAL					
		Out of Stock					
08422	1	YUENGL LAGER	089924849506	11.00	123.00	30.00	153.00
		YUENGLING LAGER 1/2 BBL 15.5 GAL					
99152	-2	MILLER RETURNS	000000000000	0.00	0.00	30.00	-60.00
		MILLER EMPTY 1/2 BBL					
99356	-1	CRAFT RETURNS	000000000000	0.00	0.00	30.00	-30.00
		CRAFT EMPTY KEGS					
99552	-1	BOSTON RETURNS	000000000000	0.00	0.00	30.00	-30.00
		BOSTON EMPTY 1/2 BBL					
99252	-1	BLUE MOON RETU	000000000000	0.00	0.00	30.00	-30.00
		BLUE MOON EMPTY 1/2 BBL					
99652	-1	YUENGLING RETS	000000000000	0.00	0.00	30.00	-30.00
		YUENGLING EMPTY 1/2 BBL					

*Handwritten signature in blue ink*

Beer: 0 + 3 Kegs      \$459.00  
Wine & Liq: 0      \$0.00  
Soft Drink: 0      \$0.00  
Misc: 0      \$0.00  
Credits: -6      -\$180.00

*Handwritten notes:*  
Rev'd 1/20/25  
~~240~~ 1342 1308R  
000  
\$ 279.00

Total Selling Units:	-3
Total Sales	402.00
Total Discount	-33.00
<hr/>	
Total Content	369.00
Total Deposit	90.00
Total Credits	-190.00
Over/Short	0.00
<hr/>	
<b>Invoice Total</b>	<b>279.00</b>

I ACCEPT THIS PRODUCT DELIVERY IN SALEABLE CONDITION.  
YOUR SIGNATURE IS ACCEPTANCE OF ALL ABOVE ITEMS. PLEASE CHECK CAREFULLY.  
Thank you!

Customer Signature:

Driver Signature:

ACH

Champion Brands Inc.  
PO BOX 56260  
Jacksonville, FL 32201  
(904)-268-1220  
Tue Jan 21, 2025 2:50 PM

Account: 23384  
SOUTH VILLAGE COMMUNITY D  
EAGLE LANDING GOLF CLUB  
3989 EAGLE LANDING PKWAY  
ORANGE PARK, FL 32065  
(904) 291-5600

Invoice#: 3533737 PO#:  
License : 2001434 Expires N/A  
Load : 281  
Terms : FINTECH  
Driver : 81 - Z. GONZALES  
Salesrep: B01 - HUNTER LABBIE

ITEM#	QTY DESCRIPTION	U.P.C.	Disc	D.PRICE	DEP	EXT
05176	1 COORS LIGHT COORS LIGHT ALUMINUM 24/16 CAN	071990301064	3.25	26.25	0.00	26.25
09039	1 GUINNESS PUB GUINNESS PUB 6/4/14.9 CAN	083820123609	0.00	43.85	0.00	43.85
07754	8 HEINEKEN 0.0 HEINEKEN 0.0 4/6/12 CANS	072890006202	0.00	36.80	0.00	0.00
48208	3 LEIN SUM SHAND LEINENKUGEL SUMMER SHANDY #2/12/12 CANS	034100516093	0.00	38.35	0.00	115.05
57274	9 LITE LITE ALUMINUM 24/16 CAN	034100003760	3.25	26.25	0.00	236.25
90094	1 RB EDITIONS RED BULL YELLOW EDITION 80Z SINGLE	611269163452	0.00	41.50	0.00	41.50
90035	1 RB ENERGY DRIN RED BULL ENERGY DRINK 80Z SINGLES	611269991000	0.00	41.50	0.00	41.50

Beer: 14 + 0 Kegs \$421.40  
Wine & Liq: 0 \$0.00  
Soft Drink: 2 \$83.00  
Misc: 0 \$0.00  
Credits: 0 \$0.00



~~240-1342~~ 3000  
421.40

~~240-1360~~ 83.00  
0000

Total Selling Units:	70
Total Sales	536.90
Total Discount	-32.50
Total Content	504.40
Total Deposit	0.00
Total Credits	0.00
Over/Short	0.00
Invoice Total	504.40

I ACCEPT THIS PRODUCT DELIVERY IN SALEABLE CONDITION.  
YOUR SIGNATURE IS ACCEPTANCE OF ALL ABOVE ITEMS. PLEASE CHECK CAREFULLY.  
Thank you!

Customer Signature: 

Driver Signature:

AGLE LANDING GOLF CLUB  
 GMP MANAGERS 11 LLC  
 989 EAGLE LANDING PKWY  
 RANGE PARK FL 32065  
 H: 904-291-5600



6031 Madison Avenue  
 Tampa, FL 33619  
 Phone: (813) 672-6161

FED# FL-P-21520  
 IMP# FL-I-21446  
 STATE#KLD3900175

\*\* INVOICE \*\*



CUSTOMER #	INVOICE DATE	INVOICE #
700026767	1/28/2025	119773807

ACH

All requests for returns must be in writing within 10 days of delivery.

ITEM #	#CASE	#BTL	SIZE	DESCRIPTION	UPC	PACK	UNIT	DISCOUNT	NET CASE	NET BOTTLE	EXTENDED AMOUNT
329 11	SPECIAL INSTRUCTIONS			PURCHASE ORDER #		REP	DUE DATE	CREDIT TERMS			
	DELIVER 7 AM - 6 PM.					0792	02/10/25	EFT NET 10 days			
331293		1	750ML	BLANTONS BRBN SMGL BBL 6B 750ML		6	62.10			62.10	62.10
127710		2	1L	JACK DANIELS TN HONEY 70 1L		12	36.70			36.70	73.40
331569		1	750ML	SAZERAC RYE WHSKY 6YR 90 6B 750ML		6	25.34			25.34	25.34
220188	1		50ML	FIREBALL CINN WHSKY PET 12/10PK 50ML		120	73.20		73.20	0.61	73.20
301700	1		750ML	MILAGRO TEQ SLVR 6B 750ML		6	182.40	29.40	153.00	25.50	153.00
236294	1		750ML	STIRRINGS MARG MIXER 5 CAL NA 6B 750ML		6	31.50		31.50	5.25	31.50
308350	2		750ML	STIRRINGS MARG MIXER NA 6B 750ML		6	31.50		31.50	5.25	63.00
				Delivery Charge							12.50
184186			750ML	EH TAYLOR BRBN SM BATCH 100 6B 750ML Out of Stock							

*Raw 1/28/25*  
*240-1360-394.50*  
*240-1342-399.54*  
*OOO*  
*Liquor*  
*Customer Signature:*

To offset rising operational costs and maintain the highest level of service, BBG-FL will implement minor split case and delivery fee adjustments effective 1/24/25.				Customer Signature:				
3.698				Thank you for your order. We appreciate your business.				
Cases	Bottles	7 Bottles	Empty Keg Returns	Access PAY NOW, Breakthru's online payment portal to manage invoice payments.	License #	Sales Tax #	Discount	Total Amount Due
ZOR	5	4	148		2001434 11CG	999999	29.40	494.04

Facebook [www.facebook.com/breakthrubevFL](http://www.facebook.com/breakthrubevFL)  
 Twitter [@breakthrubevFL](https://twitter.com/breakthrubevFL)  
 Instagram [www.instagram.com/breakthrubevFL](http://www.instagram.com/breakthrubevFL)

Visit [now.breakthrubev.com](http://now.breakthrubev.com) to register your account today!



STATE BEVERAGE LAWS REQUIRE FULL PAYMENT OF THIS INVOICE ON OR BEFORE DUE DATE SHOWN. PAYMENTS MADE AFTER DUE DATE, RETURNED PAYMENTS AND PAST DUE INVOICES WILL RESULT IN LOST DISCOUNTS AND THE GROSS TOTAL WILL BE DUE. CUSTOMERS RESPONSIBLE FOR ALL COSTS OF COLLECTION. IN THE EVENT SUIT IS FILED TO RECOVER AN UNPAID BALANCE, CUSTOMERS RESPONSIBLE FOR ALL COSTS, INTEREST AND REASONABLE ATTORNEY'S FEES.





3176 Old Jennings Road, Middleburg, FL 32068-3907

Account Summary:

Thank you for keeping your account current!

Previous Statement Balance	\$66.59
Payments	-\$66.59
Current Charges Due 01/30/2025	\$73.36
<b>Total Amount Due</b>	<b>\$73.36</b>

Account Information

Bill Date: 01/09/25 Billing Cycle: 4  
 Account Number: A00024256  
 South Village CDD  
 1433-2 Eagle Crossing Drive Golf Course  
 Restrooms, Orange Park

Customer Service (8am-5pm M-F)  
 904-272-5999

All accounts not paid by due date  
 are subject to a \$3.42 late fee.

Email  
 billing@clayutility.org

Online  
<https://www.clayutility.org/>

X @CCUA

Facebook  
 CCUAFL

Current Charges	Rate	Usage	Total
Water			
Potable Base Charge			\$13.08
Potable Water Usage - Tier 1	\$2.71	3,598 kGal	\$9.75
AWS Surcharge			\$1.22
Sewer			
Sewer Base Charge			\$29.81
Sewer Usage Charge - Tier 1	\$5.42	3,598 kGal	\$19.50
<b>Total Current Charges</b>			<b>\$73.36</b>

Usage Profile (KGAL = 1,000 gallons)

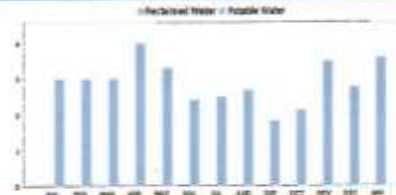

Meter Readings

Water Meter

Read Dates: 11/27/24 - 01/03/25	Days: 37	
Meter: 69235510	Previous Read: 500,076	Current Read: 503,674

7800-400 73.36  
 7581-500 2.45 \*Convenience Fee\*

PAID BY PHONE 1/29  
 CONF #325661

*Handwritten notes:*  
 400-700  
 8/11/24  
 1/29/25

Message Board

Water Quality Reports are sent by email, online at [www.clayutility.org/wqr/WQR.pdf](http://www.clayutility.org/wqr/WQR.pdf), or at our office. To receive a copy by mail, contact 904-272-5999.

Retain this portion for your records.

Please return bottom portion along with your payment to Clay County Utility Authority.



Clay County Utility Authority  
 3176 Old Jennings Road  
 Middleburg, FL 32068-3907

Bill Date: 01/09/25  
 Due Date: 01/30/25  
 Account Number: A00024256  
 Service Address: 1433-2 Eagle Crossing Drive Golf Course Restrooms, Orange Park

If paid after due date the account is subject to \$3.42 late fee.

**Total Amount Due** ~~\$73.36~~  
**75.81**

Donate to Lend a Helping Hand Program:  
 \$1  \$5  \$10  Other \_\_\_\_\_

AY10110A  
 200000457 17/6

SOUTH VILLAGE CDD  
 3989 EAGLE LANDING PKWY  
 ORANGE PARK, FL 32065, UNITED STATES



CLAY COUNTY UTILITY AUTHORITY  
 3176 OLD JENNINGS ROAD  
 MIDDLEBURG, FL 32068-3907





Account Summary:

Thank you for keeping your account current!

Previous Statement Balance	\$4,789.33
Payments	-\$4,789.33
Current Charges Due 01/30/2025	\$2,524.87
<b>Total Amount Due</b>	<b>\$2,524.87</b>

3176 Old Jennings Road, Middleburg, FL 32068-3907



Account Information

Bill Date: 01/09/25 Billing Cycle: 4  
 Account Number: A00024298  
 South Village CDD  
 878 -1 Oakleaf Plantation Parkway Reclaimed  
 Irrigation, Orange Park

Customer Service (Mon-Fri 9AM-5PM)  
 (904) 272-5999

All accounts not paid by due date  
 are subject to a \$3.42 late fee.

Email  
 billing@clayutility.org

Online  
<https://www.clayutility.org/>

Facebook  
 CCUAFL

Current Charges	Rate	Usage	Total
Water			
Reclaimed Irrigation Usage - Tier 1	\$0.55	4,590.68 kGal	\$2,524.87
<b>Total Current Charges</b>			<b>\$2,524.87</b>

*Handwritten:* 400-7800  
 to APC  
 1/29/25

Meter Readings

Other Meter		
Read Dates: 11/27/24 - 01/03/25		Days: 37
Meter	Previous Read	Current Read
84501490	369,484,720	374,075,400

7800-400 2,524.87  
 7581-500 2.45 \*Convenience Fee\*

PAID BY PHONE 1/29  
 CONF #361753

Message Board

Water Quality Reports are sent by email, online at [www.clayutility.org/wqr/WQR.pdf](http://www.clayutility.org/wqr/WQR.pdf), or at our office. To receive a copy by mail, contact 904-272-5999.

Retain this portion for your records.

Please return bottom portion along with your payment to Clay County Utility Authority.



Clay County Utility Authority  
 3176 Old Jennings Road  
 Middleburg, FL 32068-3907

Bill Date: 01/09/25  
 Due Date: 01/30/25  
 Account Number: A00024298  
 Service Address: 878 -1 Oakleaf Plantation Parkway Reclaimed  
 Irrigation, Orange Park

If paid after due date the account is subject to \$3.42 late fee.

**Total Amount Due** **\$2,524.87**  
**2,527.32**

Donate to Lend a Helping Hand Program:  
 \$1  \$5  \$10  Other \_\_\_\_\_

AY10110A  
 3000000455 17/4

SOUTH VILLAGE CDD  
 3969 EAGLE LANDING PKWY  
 ORANGE PARK, FL 32065, UNITED STATES



CLAY COUNTY UTILITY AUTHORITY  
 3176 OLD JENNINGS ROAD  
 MIDDLEBURG, FL 32068-3907



Account Summary:

Thank you for keeping your account current!

Previous Statement Balance	\$54.05
Payments	-\$54.05
Current Charges Due 01/30/2025	\$60.94
<b>Total Amount Due</b>	<b>\$60.94</b>

3176 Old Jennings Road, Middleburg, FL 32068-3907



Account Information

Bill Date: 01/09/25      Billing Cycle: 4  
 Account Number: A00030751  
 South Village CDD  
 4154 Eagle Landing Parkway Reclaimed  
 Irrigation, Orange Park

Customer Service (Mon-Sun 9-5)  
904-272-5999

All accounts not paid by due date  
are subject to a \$3.42 late fee.

Email  
billing@clayutility.org

Online  
<https://www.clayutility.org/>

X  
@CCUA

Facebook  
CCUAFL

Current Charges	Rate	Usage	Total
Reclaimed			
Reuse Base Charge			\$49.47
Reuse Water Usage - Tier 1	\$0.98	11,709 kGal	\$11.47
<b>Total Current Charges</b>			<b>\$60.94</b>

Usage Profile (KGAL = 1,000 gallons)

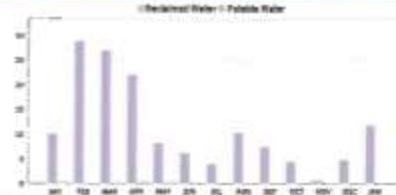

Meter Readings

Reclaimed Water		
Read Dates: 11/27/24 - 01/03/25		Days: 37
Meter: 82100743	Previous Read: 711,113	Current Read: 722,822

7800-400      60.94  
 7581-500      2.45 \*Convenience Fee\*

PAID BY PHONE 1/29  
CONF #228115

*Handwritten notes:*  
 400-7800  
 8/25  
 AA  
 1/29/25

Message Board

Water Quality Reports are sent by email, online at [www.clayutility.org/wqr/WQR.pdf](http://www.clayutility.org/wqr/WQR.pdf), or at our office. To receive a copy by mail, contact 904-272-5999.

Retain this portion for your records.

Please return bottom portion along with your payment to Clay County Utility Authority.



Clay County Utility Authority  
 3176 Old Jennings Road  
 Middleburg, FL 32068-3907

Bill Date: 01/09/25  
 Due Date: 01/30/25  
 Account Number: A00030751  
 Service Address: 4154 Eagle Landing Parkway Reclaimed Irrigation,  
 Orange Park

If paid after due date the account is subject to \$3.42 late fee.

**Total Amount Due**      **\$60.94**  
 63.39

Donate to Lend a Helping Hand Program:  
 \$1    \$5    \$10    Other \_\_\_\_\_

AY10118A  
2000000454 17/3

SOUTH VILLAGE CDD  
 3999 EAGLE LANDING PKWY  
 ORANGE PARK, FL 32065, UNITED STATES



CLAY COUNTY UTILITY AUTHORITY  
 3176 OLD JENNINGS ROAD  
 MIDDLEBURG, FL 32068-3907



3176 Old Jennings Road, Middleburg, FL 32068-3907



### Account Summary:

Thank you for keeping your account current!

Previous Statement Balance	\$190.07
Payments	-\$190.07
Current Charges Due 01/30/2025	\$86.27
<b>Total Amount Due</b>	<b>\$86.27</b>

### Account Information

Bill Date: 01/09/25      Billing Cycle: 4  
 Account Number: A00024255  
 South Village CDD  
 890 Oakleaf Plantation Parkway Golf Course  
 Mait Bldg, Orange Park

Customer Service (Mon-Fri 8-4)  
 (904) 272-5999

Online  
<https://www.clayutility.org/>

All accounts not paid by due date  
 are subject to a \$3.42 late fee.

X  
 @CCUA

Email  
 billing@clayutility.org

Facebook  
 CCUAFL

Current Charges	Rate	Usage	Total
<b>Water</b>			
Potable Base Charge			\$19.62
Potable Water Usage - Tier 1	\$2.71	3.015 kGal	\$8.17
AW5 Surcharge			\$1.22
<b>Sewer</b>			
Sewer Base Charge			\$40.92
Sewer Usage Charge - Tier 1	\$5.42	3.015 kGal	\$16.34
<b>Total Current Charges</b>			<b>\$86.27</b>

### Usage Profile (KGAL = 1,000 gallons)

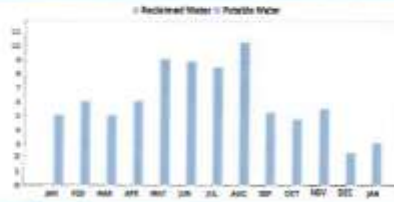

### Meter Readings

#### Water Meter

Read Dates: 11/25/24 - 01/03/25      Days: 39  
 Meter: 85887693      Previous Read: 1,069,231      Current Read: 1,072,246

7800-400      86.27  
 7581-500      2.45 \*Convenience Fee\*

PAID BY PHONE 1/29  
 CONF #152456

*Handwritten notes:*  
400-200  
APC  
I have

### Message Board

Water Quality Reports are sent by email, online at [www.clayutility.org/wqr/WQR.pdf](http://www.clayutility.org/wqr/WQR.pdf), or at our office. To receive a copy by mail, contact 904-272-5999.

Retain this portion for your records.

Please return bottom portion along with your payment to Clay County Utility Authority.



**Clay County Utility Authority**  
 3176 Old Jennings Road  
 Middleburg, FL 32068-3907

Bill Date: 01/09/25  
 Due Date: 01/30/25  
 Account Number: A00024255  
 Service Address: 890 Oakleaf Plantation Parkway Golf Course Mait Bldg, Orange Park

If paid after due date the account is subject to \$3.42 late fee.

**Total Amount Due**      **\$86.27**  
    **88.72**

Donate to Lend a Helping Hand Program:  
 \$1    \$5    \$10    Other \_\_\_\_

AY10110A  
 2000000453 17/2

SOUTH VILLAGE CDD  
 3989 EAGLE LANDING PKWY  
 ORANGE PARK, FL 32065, UNITED STATES



CLAY COUNTY UTILITY AUTHORITY  
 3176 OLD JENNINGS ROAD  
 MIDDLEBURG, FL 32068-3907



3176 Old Jennings Road, Middleburg, FL 32068-3907

### Account Summary:

Thank you for keeping your account current!

Previous Statement Balance	\$148.15
Payments	-\$148.15
Current Charges Due 01/30/2025	\$68.29
<b>Total Amount Due</b>	<b>\$68.29</b>

### Account Information

**Bill Date:** 01/09/25      **Billing Cycle:** 4  
**Account Number:** A00024263  
 South Village CDD  
 4045 -2 Eagle Crossing Drive Golf Course  
 Restrooms, Orange Park

Customer Service (8am-5pm M-F)  
 (904) 272-5999  
 All accounts not paid by due date  
 are subject to a \$3.42 late fee.  
 Email: billing@clayutility.org

Online: <https://www.clayutility.org/>  
 X: @CCUA  
 Facebook: CCUAF

Current Charges	Rate	Usage	Total
<b>Water</b>			
Potable Base Charge			\$13.08
Potable Water Usage - Tier 1	\$2.71	2,975 kGal	\$8.06
AW5 Surcharge			\$1.22
<b>Sewer</b>			
Sewer Base Charge			\$29.81
Sewer Usage Charge - Tier 1	\$5.42	2,975 kGal	\$16.12
<b>Total Current Charges</b>			<b>\$68.29</b>

### Usage Profile (KGAL = 1,000 gallons)

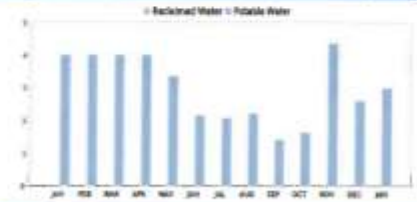

### Meter Readings

Water Meter		
Read Dates:	11/27/24 - 01/03/25	Days: 37
Meter:	70956036	Previous Read: 363,748
		Current Read: 366,723

*Handwritten signature and number 400-7800*

7800-400      68.29  
 7581-500      2.45 \*Convenience Fee\*  
**PAID BY PHONE 1/29**  
**CONF #733445**

### Message Board

Water Quality Reports are sent by email, online at [www.clayutility.org/wqr/WQR.pdf](http://www.clayutility.org/wqr/WQR.pdf), or at our office. To receive a copy by mail, contact 904-272-5999.

Retain this portion for your records. Please return bottom portion along with your payment to Clay County Utility Authority.



**Clay County Utility Authority**  
 3176 Old Jennings Road  
 Middleburg, FL 32068-3907

**Bill Date:** 01/09/25  
**Due Date:** 01/30/25  
**Account Number:** A00024263  
**Service Address:** 4045 -2 Eagle Crossing Drive Golf Course Restrooms, Orange Park

Donate to Lend a Helping Hand Program:  
 \$1    \$5    \$10    Other \_\_\_\_\_

If paid after due date the account is subject to \$3.42 late fee.  
**Total Amount Due**      ~~\$68.29~~  
    **70.74**

AY10110A  
2000000452 17/1



SOUTH VILLAGE CDD  
 3989 EAGLE LANDING PKWY  
 ORANGE PARK FL 32065 UNITED FL 32065-2641



CLAY COUNTY UTILITY AUTHORITY  
 3176 OLD JENNINGS ROAD  
 MIDDLEBURG, FL 32068-3907





Account Number  
8495 74 144 1687294

Billing Date  
Jan 11, 2025

Services From  
Jan 15, 2025 to Feb 14, 2025

Page  
1 of 3

# Hello Eastwest Communities,

Thanks for choosing Comcast Business.

## Your bill at a glance

For 3979 EAGLE LANDING PKWY, BOX MDTA-2, ORANGE PARK, FL, 32065-0000

Previous balance		\$696.24
One-time EFT Payment - thank you Jan 02		-\$696.24
<b>Balance forward</b>		<b>\$0.00</b>
Regular monthly charges	Page 3	\$316.50
One-time charges	Page 3	\$3.95
Taxes, fees and other charges	Page 3	\$30.81
<b>New charges</b>		<b>\$351.26</b>

**Amount due Feb 01, 2025 \$351.26**

## Your bill explained

- Regular monthly charges have decreased by \$3.95 as a result of service change(s) made to TV services and Comcast Business.
- Your one-time charges are \$3.95 due to Paper Statement Fee charge(s).
- Any payments received or account activity after Jan 11, 2025 will show up on your next bill. View your most up-to-date account balance at [business.comcast.com/myaccount](https://business.comcast.com/myaccount).



### Need help?

Visit [business.comcast.com/help](https://business.comcast.com/help) or see page 2 for other ways to contact us.

*Answered Pro 7/7  
Exempt from set  
SW-7835  
APR 1/20/25  
\$336.26  
AG Yhis Amt*

Detach the bottom portion of this bill and enclose with your payment

Please write your account number on your check or money order

Do not include correspondence with payment



1100 NORTHPOINT PKWY W PALM  
BCH FL 33407-1937  
06330310 NO RP 11 20250111 NNNNNNY 0000002 0004

EASTWEST COMMUNITIES  
3979 EAGLE LANDING PKWY  
BOX MDTA-2  
ORANGE PARK FL 32065-2065

Account number **8495 74 144 1687294**  
Payment due **Feb 01, 2025**

Please pay **\$351.26**

Amount enclosed \$

Make checks payable to Comcast  
Do not send cash



Send payment to  
COMCAST

Regular monthly charges		\$316.50
Comcast Business		\$316.50
<b>TV services</b>		<b>\$316.50</b>
TV Standard		\$74.95
Business Video		
CableCARD	✓	
Qty 6 @ \$0.00 each		
Digital Adapter	✓	
Equipment Fee		\$200.00
TV Box		
Broadcast TV Fee		\$37.10
Regional Sports Fee		\$4.45

What's included?

 **TV:** Keep your employees informed and customers entertained

This shows a service is included in your package: ✓

Visit [business.comcast.com/myaccount](https://business.comcast.com/myaccount) for more details



One-time charges		\$3.95
<b>Other charges</b>		<b>\$3.95</b>
Paper Statement Fee	Jan 11	\$3.95

Taxes, fees and other charges		\$30.81
<b>Other charges</b>		<b>\$0.12</b>
Regulatory Cost Recovery		\$0.12

Taxes & government fees		\$30.69
Sales Tax		\$15.00
State Communications Services Tax		\$8.67
Local Communications Services Tax		\$7.02

Additional information

**Understanding your video costs:** Your monthly bill statement now shows the combined price for your Business Video package, including the monthly recurring charge and any TV-related fees. These fees used to appear separately, but now all video expenses are in one place. If you have any questions, please visit [business.comcast.com/understand-your-bill](https://business.comcast.com/understand-your-bill) or call us at 800-391-3000 for a change of service request.

**Parental Controls:** With parental controls, you can choose and manage the programming that is right for your family. Learn more at: [business.comcast.com/support/article/tv/x1-parental-controls-safe-browse](https://business.comcast.com/support/article/tv/x1-parental-controls-safe-browse).

**Recent and Upcoming Programming Changes:** Information on recent and upcoming programming changes can be found at [xfinity.com/programmingchanges/](https://xfinity.com/programmingchanges/) or by calling 866-216-8634.



Champion Brands Inc.  
 PO BOX 56260  
 Jacksonville, FL 32241  
 (904)-268-1220  
 Tue Jan 28, 2025 3:37 PM

Account: 23384      Invoice#: 3538857      PO#:      License: 2001434 Expires N/A  
 SOUTH VILLAGE COMMUNITY O      Load : 201  
 EAGLE LANDING GOLF CLUB      Terms : FINTECH  
 3989 EAGLE LANDING PKWAY      Driver : 01 - T. FLICK  
 ORANGE PARK, FL 32065      Salesrep: B01 - HUNTER LABBIE  
 (904) 291-5600

ITEM#	QTY	DESCRIPTION	U.P.C.	Disc	D.PRICE	DEP	EXT
896003	5	SUN CRUISER	087692020301	13.50	36.00	0.00	180.00
		3/8/12 VARIETY	3/8/12 CAN				
600006	1	WATERBIRD	060005649570	1.93	47.52	0.00	47.52
		6/4/12 VODKA TRANSFUS WB VODKA TRANS 6/4					

Beer: 0 = 0 Kegs      \$0.00  
 Wine & Liq: 6      \$227.52  
 Soft Drink: 0      \$0.00  
 Misc: 0      \$0.00  
 Credits: 0      \$0.00

*Rec'd at 1/28/25*  
~~240~~ <sup>000</sup> .1346 liquor  
 \$227.52

Total Selling Units:	21
Total Sales	296.95
Total Discount	-69.43
Total Content	227.52
Total Deposit	0.00
Total Credits	0.00
Over/Short	0.00
<b>Invoice Total</b>	<b>227.52</b>

*[Handwritten signature]*  
 2/3/25

I ACCEPT THIS PRODUCT DELIVERY IN SALEABLE CONDITION.  
 YOUR SIGNATURE IS ACCEPTANCE OF ALL ABOVE ITEMS. PLEASE CHECK CAREFULLY.  
 Thank you!

Customer Signature:

Driver Signature:

*[Handwritten signature]*

**Champion Brands Inc.**  
 PO BOX 56260  
 Jacksonville, FL 32241  
 (904)-268-1220  
 Tue Jan 28, 2025 3:37 PM

Account: 23384      **Invoice#:** 3538859      PO#:  
 SOUTH VILLAGE COMMUNITY D      License : 2001434 Expires N/A  
 EAGLE LANDING GOLF CLUB      Load : 201  
 3989 EAGLE LANDING PKWAY      Terms : FINTECH  
 ORANGE PARK, FL 32065      Driver : 01 - T. FLICK  
 (904) 291-5600      Salesrep: 801 - MWTR LABBIE

ITEM#	QTY	DESCRIPTION	U.P.C.	Disc	D.PRICE	DEP	EXT
09039	1	GUINNESS PUB	083820123609	0.00	43.85	0.00	43.85
		GUINNESS PUB 6/4/14.9 CAN					
07702	1	HEINEKEN	072890000200	0.00	36.80	0.00	36.80
		HEINEKEN 2/12/12 CAN					
07757	1	HEINEKEN 0.0	072890006547	0.00	36.80	0.00	36.80
		HEINEKEN 0.0 2/12/11.2 CAN					
48208	1	LEIN SUM SHAND	034100516093	0.00	38.35	0.00	38.35
		LEINENKUGEL SUMMER SHANDY #2/12/12 CANS					
90121	1	RB EDITIONS	611269333213	0.00	41.50	0.00	41.50
		RED BULL EDITIONS RED 80Z 4PK					
90094	1	RB EDITIONS	611269163452	0.00	41.50	0.00	41.50
		RED BULL YELLOW EDITION 80Z SINGLE					
90035	1	RB ENERGY DRIN	611269991000	0.00	41.50	0.00	41.50
		RED BULL ENERGY DRINK 80Z SINGLES					
90193	1	RB SF EDITIONS	611269002034	0.00	41.50	0.00	41.50
		RED BULL EDITIONS SUGAR FREE RED 80Z SINGLES					
90036	1	RB SUGAR FREE	611269101713	0.00	41.50	0.00	41.50
		RED BULL SUGAR FREE 80Z SINGLES					
19464	1	SN LITTLE THIN	083783110104	0.00	38.35	0.00	38.35
		SIERRA HAZY LITTLE THING 4/6/12 CANS					
09650	3	YUENG LAGER	089924532491	4.30	26.25	0.00	78.75
		YUENGLING LAGER 4/6/16 CAN					

*Handwritten signature and date: 2/3/25*

Beer: 7 + 0 Kegs      \$236.10  
 Wine & Liq: 0      \$0.00  
 Soft Drink: 6      \$244.30  
 Misc: 0      \$0.00  
 Credits: 0      \$0.00

	Total Selling Units:	130
	Total Sales	493.30
	Total Discount	-12.90
<hr/>		
	Total Content	480.40
	Total Deposit	0.00
	Total Credits	0.00
	Over/Short	0.00
<hr/>		
	Invoice Total	480.40

*Handwritten notes:*  
 Rew ft 1/28/25  
 000 071612  
~~240~~-1360 - 207.50  
 000 30012  
~~240~~-1342 - 272.90

I ACCEPT THIS PRODUCT DELIVERY IN SALEABLE CONDITION.  
 YOUR SIGNATURE IS ACCEPTANCE OF ALL ABOVE ITEMS. PLEASE CHECK CAREFULLY.  
 Thank you!

Customer Signature:      Driver Signature:

Champion Brands Inc.  
 PO BOX 56260  
 Jacksonville, FL 32241  
 (904)-268-1220  
 Tue Jan 28, 2025 3:29 PM

Account: 23384      Invoice#: 3538860      PO#:  
 SOUTH VILLAGE COMMUNITY D      License : 2001434 Expires N/A  
 EAGLE LANDING GOLF CLUB      Load : 201  
 3989 EAGLE LANDING PKWAY      Terms : FINTECH  
 ORANGE PARK, FL 32065      Driver : 01 - T. FLICK  
 (904) 291-5600      Salesrep: 801 - HUNTER LABBIE

ITEM#	QTY	DESCRIPTION	U.P.C.	Disc	D.PRICE	DEP	EXT
05252	1	BLUE MOON	071990095154	5.00	171.00	30.00	201.00
		BLUE MOON 1/2 BBL 15.5 GAL					
57152	1	LITE	03410005344	11.00	123.00	30.00	153.00
		LITE 1/2 BBL 15.5 GAL					
09398	1	SAM SEASONAL	087692019992	0.00	176.00	30.00	206.00
		SAM ADAMS COLD SNAP 1/2 BBL 15.5 GAL					
08422	1	YUENG LAGER	089924849506	11.00	123.00	30.00	153.00
		YUENGLING LAGER 1/2 BBL 15.5 GAL					
99555	-1	BOSTON RETURNS	000000000000	0.00	0.00	30.00	-30.00
		BOSTON EMPTY 1/6 BBL					
99152	-1	MILLER RETURNS	000000000000	0.00	0.00	30.00	-30.00
		MILLER EMPTY 1/2 BBL					

Beer: 0 + 4 Kegs      \$713.00  
 Wine & Liq: 0      \$0.00  
 Soft Drink: 0      \$0.00  
 Misc: 0      \$0.00  
 Credits: -2      -\$60.00

*Rev dt 1/28/25* Total Selling Units: 2  
 Total Sales: 620.00  
 Total Discount: -27.00  
 Total Content: 593.00  
 Total Deposit: 120.00  
 Total Credits: -60.00  
 Over/Short: 0.00  
 Invoice Total: 653.00

*000*  
~~240~~ 1342 beer

*\$653.00*

*16*  
*1/31/25*

ACCEPT THIS PRODUCT DELIVERY IN SALEABLE CONDITION.  
 YOUR SIGNATURE IS ACCEPTANCE OF ALL ABOVE ITEMS. PLEASE CHECK CAREFULLY.  
 Thank you!

Customer Signature:

Driver Signature:



3601 Rosent Blvd.  
 Jacksonville, FL 322  
 (904) 645-0283  
 WFSales.net

EAGLE LANDING GOLF C  
 3909 EAGLE LANDING P  
 ORANGE PARK, FL 3206  
 BEV2001434  
 Brooke Simard

Stacy McClellan

Fintech

Date	Invoice	LeadSheet	Vendor	PO Num			
01/28/2025	4099949	292325		21117298			
Route	Customer	Deliveries	Salesman				
1504 TUES	101152	AMATTHEWS	APT_11825				
ID	QTY	PRODUCT	PRICE	DEP	DISC	NET	TOTAL
1805	111	EMPTY 1/2 BBL	\$30.00			\$33.00	(\$30.00)
53504	2	BUD LT 2/12 16OZ TWST AL B	\$30.60			\$30.60	\$61.20
227	1	CORONA EXTRA 2/12 B	\$32.80			\$32.80	\$32.80
9289	1	STELLA 4/6 12oz C	\$35.05			\$35.05	\$35.05
76378	4	ULTRA 2/12 16OZ AL TW	\$35.80			\$35.80	\$143.20
5	1	BEER 22.5000 Gallons	\$0.00	\$0.00			

*Rec'd at 1/28/25*

000  
~~240~~ 1342  
*Boyd*

Total \$243.25  
 Charges \$273.25  
 Credits \$30.00  
 Total \$243.25

*\$243.25*

*[Handwritten signature]*  
 1/28/25

ERN GLAZER'S OF FL  
 ILD TAMPA HIGHWAY  
 AND, FLORIDA

REMIT TO:	
SOUTHERN GLAZER'S OF FL	
P.O. BOX 947921	
ATLANTA, GA 30394-7921	
1-866-375-9555	



INVOICE NUMBER	3677464	
ACCOUNT NUMBER	85510	
ROUTE	516	STOP 7

ACH

69  
 EAGLE LANDING GOLF CLUB  
 9 EAGLE LANDING PARKWAY  
 ORANGE PARK FL 32065

S  
H  
I  
P  
  
T  
O  
  
EAGLE LANDING GOLF CLUB  
 3989 EAGLE LANDING PARKWAY  
 ORANGE PARK FL 32065



DUPLICATE  
 C O D C.O.D. FINTECH  
 FINTECH

PAGE 1 OF 2  
 1500 3 14

LAKELAND-NIGHT BILL

INVOICE NUMBER	SALES PERSON	DELIVERY INSTRUCTIONS	PHONE NUMBER	INVOICE DATE
20-01434	186	P.O.#:	904-291-5600	1/29/2025

CASES	BTLS	SIZE	DESCRIPTION	PACK	W-LOC.	B-LÖC.	PRODUCT CODE	NET BTL PRICE	UNIT PRICE	-DIV CODE	UNIT DISCOUNT	NET AMOUNT
2		750ML	DON JULIO TEQ BLANCO 80	6			971835	39.08	277.02	001	42.54	468.96
1		750ML	PATRON TEQ SILVER 80 BAR	6			109101	40.00	250.50	080	10.50	240.00
1		750ML	RODNEY STRONG CAB SAUV SONOMA 21	12			637530	12.00	252.00	003	108.00	144.00
1		750ML	WOODBRIIDGE PINOT GRIGIO SP COL(SC)	12			915650	4.00	87.00	007	39.00	48.00
1		750ML	WOODBRIIDGE PINOT NOIR	12			133770	4.50	90.00	007	36.00	54.00
2	1.0L		BACARDI RUM SUPERIOR WHITE 80	12			28728	20.12	20.12	080		40.24
1	1.0L		BOMBAY SAPPHIRE GIN 94	12			11291	32.45	32.45	080		32.45
1	1.0L		BULLEIT BOURBON 90	12			352429	36.95	36.95	001		36.95
2	1.0L		DEKUYPER BLACKBERRY BRANDY 60	12		21554	233547	14.23	14.23	003		28.46
2	1.0L		DEKUYPER PUCKER WATERMELON SCHN 30	12		20513	49357	14.23	14.23	003		28.46
1	1.0L		DEWARS WHITE LABEL 80	12			19307	32.70	32.70	080		32.70
2	1.0L		HENNESSY COGNAC VS 80	12			344101	57.20	57.20	001		114.40
2	1.0L		JAMESON IRISH WHISKEY 80	12		20693	24601	46.11	46.11	005		92.22
1	1.0L		MALIBU RUM COCONUT 42	12		20262	33451	23.78	23.78	005		23.78

C  
O  
D

Thank You For Your Business.

CASES TOTAL	6	BOTTLES TOTAL	14	WINE GALLONS		CUSTOMER	EAGLE LANDING GOLF CLUB	PAGE	1	GROSS TOTAL		TOTAL DISCOUNT		PAY THIS AMOUNT	
ORDER TOTAL	6	ORDER TOTAL	16	LIQUOR GALLONS										*** CONT ***	
BEER GALLONS										NET AMOUNT				DUE DATE	

ARTON DRIVER LOADED INVOICE NO. CUSTOMER NO. NET AMOUNT DUE DATE

Please represent that it is authorized under applicable law to purchase of the products delivered in this invoice and that all such products were ordered by the customer named on this invoice. Payment should be made to the terms of the invoice and returned to the sender. Payment should be made to the terms of the invoice and returned to the sender.



HERN GLAZER'S OF FL  
 OLD TAMPA HIGHWAY  
 AND, FLORIDA

REMIT TO:  
 SOUTHERN GLAZER'S OF FL  
 P.O. BOX 947921  
 ATLANTA, GA 30394-7921  
 1-866-375-9555



INVOICE NUMBER	3677464		
ACCOUNT NUMBER	85510		
ROUTE	516	STOP	7

GLE LANDING GOLF CLUB  
 89 EAGLE LANDING PARKWAY  
 ANGE PARK FL 32065

S  
H  
I  
P  
T  
O  
 EAGLE LANDING GOLF CLUB  
 3989 EAGLE LANDING PARKWAY  
 ORANGE PARK FL 32065

**C.O.D.**

DUPLICATE

C O D C.O.D. FINTECH  
 FINTECH

PAGE 2 OF 2  
 1500 3 14

LAKELAND-NIGHT BILL

INVOICE NUMBER	SALES PERSON	DELIVERY INSTRUCTIONS	PHONE NUMBER	INVOICE DATE
20-01434	186	P.O.#:	904-291-5600	1/29/2025

IC	CASES	RTIS	SIZE	DESCRIPTION	PACK	W-LOC.	C-LOC.	PRODUCT CODE	NET BTL. PRICE	UNIT PRICE	DV CDE	UNIT DISCOUNT	NET AMOUNT
	2		1.0L	WHISTLEPIG BBN PIGGYBACK 6YR 100	6			631413	58.45	58.45	002		116.90

*Rem. 1/29/25*  
~~240-1344~~ - 246.00  
~~240-1346~~ - 255.52  
 000  
 000  
 WIP  
 LIQUOR

*[Handwritten signature]*  
 2/3/25

Thank You For Your Business

TOTAL # BTLs: 70 YTD TOTAL DISCOUNT: 2,155.00

TOTAL ORDER TOTAL	PAGE TOTAL	ORDER TOTAL	WINE GALLONS	CUSTOMER	PAGE	GROSS TOTAL	TOTAL DISCOUNT	PAY THIS AMOUNT
6.	2	16	7.13	EAGLE LANDING GOLF CLUB	2	1,780.10	278.58	C.O.D. 1,501.52
			7.79					

ARTON	DRIVER	LOADED	INVOICE NO.	CUSTOMER NO.	NET AMOUNT	DUE DATE
-------	--------	--------	-------------	--------------	------------	----------

Buyer represents that it is authorized under applicable law to purchase all the products described in this invoice, and that all such products were ordered by Buyer and have been received without any change, unless noted on invoice.

Buyer represents that it is authorized under applicable law to purchase all the products described in this invoice, and that all such products were ordered by Buyer and have been received without any change, unless noted on invoice.



EAGLE LANDING GOLF CLUB  
 CGMP MANAGERS 11 LLC  
 3989 EAGLE LANDING PKWY  
 ORANGE PARK FL 32065  
 PH: 904-291-5600



6031 Madison Avenue  
 Tampa, FL 33619  
 Phone: (813) 672-6161

FED# FL-P-21520  
 IMP# FL-I-21446  
 STATE#KLD3900175

\*\* INVOICE \*\*



ACH

CUSTOMER #	INVOICE DATE	INVOICE #
700026767	1/30/2025	119829078

Page 1 of 1

All requests for returns must be in writing within 10 days of delivery.

OUTLET	STORE	SPECIAL INSTRUCTIONS	PURCHASE ORDER #	REP	DUE DATE	CREDIT TERMS					
0395	11	DELIVER 7 AM - 6 PM.		0792	02/10/25	EFT NET 10 days					
ITEM #	#CASE	#BTL	SIZE	DESCRIPTION	UPC	PACK	UNIT	DISCOUNT	NET CASE	NET BOTTLE	EXTENDED AMOUNT
031427		1	750ML	EAGLE RARE BRBN 10YR 6B 750ML		6	34.35			34.35	34.35
0184186		1	750ML	EH TAYLOR BRBN SM BATCH 100 6B 750ML		6	43.35			43.35	43.35
				Delivery Charge							12.50

*Handwritten notes:*  
 Jan 1/30/25  
 000  
 249-1344  
 \$90.20  
 [Signature]

To offset rising operational costs and maintain the highest level of service, BBG-FL will implement minor split case and delivery fee adjustments effective 1/30/25.

Customer Signature:

Thank you for your order. We appreciate your business.

Cases	Bottles	F Bottles	Empty Keg Returns	Access PAY NOW, Breakthru's online payment portal to manage invoice payments.	License #	Sales Tax #	Discount	Total Amount Due
ZOR	2	2			2001434 11CG	999999		90.20

Facebook [www.facebook.com/breakthrubevFL](http://www.facebook.com/breakthrubevFL)  
 Twitter @breakthrubevFL  
 Instagram [www.instagram.com/breakthrubevFL](http://www.instagram.com/breakthrubevFL)

Visit now [www.breakthrubev.com](http://www.breakthrubev.com) to register your account today!



STATE BEVERAGE LAWS REQUIRE FULL PAYMENT OF THIS INVOICE ON OR BEFORE DUE DATE SHOWN. PAYMENTS MADE AFTER DUE DATE, RETURNED PAYMENTS AND PAST DUE INVOICES WILL RESULT IN LOST DISCOUNTS AND THE GROSS TOTAL WILL BE DUE. CUSTOMERS RESPONSIBLE FOR ALL COSTS OF COLLECTION. IN THE EVENT SUIT IS FILED TO RECOVER AN UNPAID BALANCE, CUSTOMERS RESPONSIBLE FOR ALL COSTS, INTEREST AND REASONABLE ATTORNEY'S FEES.

LOAN NUMBER
<b>XXX - 102029550</b>
Refer to this number on all correspondence
CUSTOMER ID
EAGLLAN-04

### BILLING STATEMENT



**FIRST Insurance Funding**  
 450 Skokie Blvd, Ste 1000  
 Northbrook, IL 60062-7917  
 Phone: (800) 837-3707 Fax: (800) 837-3709  
 www.firstinsurancefunding.com

NOTICE DATE
1/10/2025
INSTALLMENT DUE DATE
<b>2/1/2025</b>

Insured

**EAGLE LANDING  
 C/O TROON GOLF LLC  
 15044 N SCOTTSDALE RD  
 STE 300  
 SCOTTSDALE, AZ 85254-8135**

Previous Account Balance	\$	8,706.40
Payments/Adjustments	\$	(2,176.60)
Current Account Balance	\$	6,529.80
<b>Past Due Amount</b>	\$	<b>0.00</b>
Current Installment Amount	\$	2,176.60
<b>Total Amount Due</b>	\$	<b>2,176.60</b>

Agent/Broker ARTHUR J. GALLAGHER RISK MANAGEMENT SVCS  
 Phone: (713) 623-2330

As of the date of this notice, you are enrolled in ACH Debit.

**Any Past Due Amount is due immediately.**

- Failure to pay past due amounts and your current installment amount may result in cancellation of your insurance coverage.
- If you have any questions concerning your insurance coverage, please contact your agent or broker listed above.
- If you mail your payment, please allow 7-10 days mailing time to ensure timely application of your payment.
- **Overnight delivery payments ONLY may be sent to the address listed at the top of this statement. All other payments by mail should be sent to the address listed on the Remittance Stub.**
- **AUTOPAY**  
 – If you are enrolled in ACH Debit, the amount due on your loan will be deducted from your bank account 1-2 business days following the Installment Due Date. If you are enrolled in Credit Card, the amount due on your loan will be charged to your credit card on the Installment Due Date or next business day.
- You may also pay online or by phone. Convenience fees may apply. Our contact information is listed at the top of this statement.

Please visit our website to check your loan, make a payment, change your address and view documents online!

To access your account online you will need your loan number and temporary password located on the Welcome Letter/Notice of Acceptance. If you already changed the temporary password, you can reset your password by clicking the Forgot Password link.

126120996

FIFBILL0921



### REMITTANCE STUB

A WINTRUST COMPANY  
**Please make checks payable and mail to:**  
 FIRST Insurance Funding  
 PO Box 7000  
 Carol Stream, IL 60197-7000

Have you moved? Please check this box and print your new address on the back.

NOTICE DATE	1/10/2025
-------------	-----------

LOAN NUMBER	<b>XXX - 102029550</b>
CURRENT INSTALLMENT DUE DATE:	2/1/2025

Insured

**EAGLE LANDING  
 C/O TROON GOLF LLC  
 15044 N SCOTTSDALE RD  
 STE 300  
 SCOTTSDALE, AZ 85254-8135**

Your loan is set up on AutoPay – ACH Debit

# Troon Golf LLC

15044 N Scottsdale Road  
Suite 300  
Scottsdale, AZ 85254  
USA

# Invoice



**Page** 1 of 1  
**Number** ARINV-1010-175713  
**Date** 1/1/2025  
**Customer account** 10221  
**Payment terms**  
**Currency** USD

Eagle Landing GC  
3989 Eagle Landing Parkway  
Orange Park, FL 32065  
USA

1460-000 -4,600  
1470-000 4,600  
7920-500 11,713.25  
7920-800 4,600

Description	Amount
Management Services	16,313.25 USD

Sales subtotal amount	Sales or Withholding tax	Total
16,313.25	0.00	16,313.25 USD

SOUTHERN GLAZER'S OF FL  
4440 OLD TAMPA HIGHWAY  
LAKELAND, FLORIDA  
33811

REMIT TO:  
SOUTHERN GLAZER'S OF FL  
P.O. BOX 947921  
ATLANTA, GA 30394-7921  
1-866-375-9555

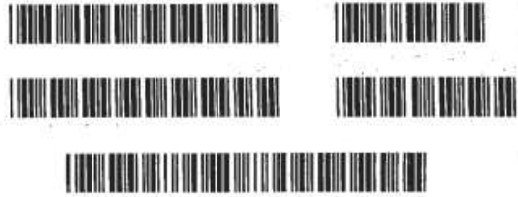

INVOICE NUMBER	3657439	
ACCOUNT NUMBER	15708	
ROUTE	516	STOP 17

EAGLE LANDING SWIM AND TENNIS  
3975 EAGLE LANDING PARKWAY  
ORANGE PARK FL 32065

EAGLE LANDING SWIM AND TENNIS  
3975 EAGLE LANDING PARKWAY  
ORANGE PARK FL 32065

**C.O.D.**  
H

S  
H  
I  
P  
T  
O

DUPLICATE  
C O D C.O.D. FINTECH

PAGE 1 OF 1  
1500 3 14

LAKELAND-NIGHT BILL

LICENSE NUMBER 20-01256	SALES PERSON 166	DELVRY INSTRUCTIONS: P.O.#:	PHONE NUMBER 904-291-3535	INVOICE DATE 1/23/2025
----------------------------	---------------------	--------------------------------	------------------------------	---------------------------

LOC	CASES	BTL	SIZE	DESCRIPTION	PACK	W-LOC.	B-LOC.	PRODUCT CODE	DESCRIPTION	NET BTL PRICE	UNIT PRICE	DIV CDE	UNIT DISCOUNT	NET AMOUNT
	1		1.0L	CASAMIGOS TEQUILA REPOSADO 80	6	84		446127		57.90	409.50	001	62.10	347.40
	1		1.0L	DUBOUCHETT PEACH SCHNAPPS 30	12			708		4.75	84.00	080	27.00	57.00
	1		1.0L	MAKERS MARK BOURBON 90	12		21653	9998		42.73	42.73	003		42.73
<b>C O D</b>														
											5530-200			
											- LIQUOR -			
											<del>200-13116</del>			
											Rec'd			
											1/22/25			
														\$ 447.13

*Swim / Tennis*

*[Handwritten signature]*

Thank You For Your Business

TOTAL # BTL'S: 19 YTD TOTAL DISCOUNT: 65.10

PAGE TOTAL	CASES ORDER TOTAL	PAGE TOTAL	BOTTLES ORDER TOTAL	WINE GALLONS	LIQUOR GALLONS	BEER GALLONS	CUSTOMER	PAGE	GROSS TOTAL	TOTAL DISCOUNT	PAY THIS AMOUNT								
2	2	1	1		5.02		EAGLE LANDING SWIM AND TE	1	536.23	89.10	<b>C O D</b> 447.13								
CARTON	DRIVER	LOADED	<small>Buyer represents that it is authorized under applicable law to purchase all the products delivered to this invoice, and that all such products were ordered by buyer and have been received without any damage, unless noted on invoice at time of delivery. SELLER EXPRESSLY DISCLAIMS ANY WARRANTY, INCLUDING OF MERCHANTABILITY OR FITNESS FOR A PARTICULAR PURPOSE. BUYER WAIVES CONSEQUENTIAL, PUNITIVE, SPECIAL, OR STATUTORY DAMAGES OR PENALTIES. The parties agree to arbitrate any dispute between them on an individual basis in Miami, FL before the American Arbitration Association in accordance with its Commercial Arbitration Rules. The parties each waive the right to serve as a class or FACA representative or to participate in a class or collective action in any legal proceeding between them.</small>																
2			<table border="0"> <tr> <td>INVOICE NO.</td> <td>CUSTOMER NO.</td> <td>NET AMOUNT</td> <td>DATE</td> </tr> <tr> <td>3657439</td> <td>15708</td> <td>447.13</td> <td>1/23/2025</td> </tr> </table>									INVOICE NO.	CUSTOMER NO.	NET AMOUNT	DATE	3657439	15708	447.13	1/23/2025
INVOICE NO.	CUSTOMER NO.	NET AMOUNT	DATE																
3657439	15708	447.13	1/23/2025																
PUT UP	CHECK BY	<small>DELIVERY RECEIPT/NO CLAIMS FOR SHORTAGES WILL BE ALLOWED UNLESS INSPECTED AND NOTED AT TIME OF DELIVERY.</small>																	

FL INVOICE

SGWS

Print Name

Signature



SOUTHERN GLAZER'S OF FL  
4440 OLD TAMPA HIGHWAY  
LAKELAND, FLORIDA  
33811

69

S O L D  
EAGLE LANDING GOLF CLUB  
3989 EAGLE LANDING PARKWAY  
ORANGE PARK FL 32065

**C.O.D.** H

REMIT TO:  
SOUTHERN GLAZER'S OF FL  
P.O. BOX 947921  
ATLANTA, GA 30394-7921  
1 888-375-9555

S H I P  
EAGLE LANDING GOLF CLUB  
3989 EAGLE LANDING PARKWAY  
ORANGE PARK FL 32065

T O

DUPLICATE

C O D C.O.D. FINTECH  
FINTECH

INVOICE NUMBER	3658560	
ACCOUNT NUMBER	85510	
ROUTE	516	STOP 18

PAGE 1 OF 2  
1500 3 14

LAKELAND-NIGHT BILL

LICENSE NUMBER	SALES PERSON	DELVRY INSTRUCTIONS:	PHONE NUMBER	INVOICE DATE
20-01434	186	P.O.#:	904-291-5600	1/23/2025

LOC	CASES	BTLs	SIZE	DESCRIPTION	PACK	W4LOC	B4LOC	PRODUCT CODE	NET WTL PRICE	UNIT PRICE	DRY CODE	UNIT DISCOUNT	NET AMOUNT
	1		1.0L	ARISTOCRAT VODKA 80	12			69057	6.25	128.04	080	53.04	75.00
	1		750ML	DON JULIO TEQ BLANCO 80	6			971835	43.50	277.02	001	16.02	261.00
	2		240ML	OWENS MIXERS ESPRESSO MARTIN CAN4P	6	1028		561669	10.17	81.00	002	19.98	122.04
	1		750ML	SUTTER HOME MOSCATO(SC)	12			513862	4.40	81.00	003	28.20	52.80
	3		1.0L	TITOS HANDMADE VODKA 80	12			46599	23.00	340.56	002	64.56	828.00
	2		50ML	TITOS HANDMADE VODKA 80 5/12PK SLV	5			974536	18.76	117.80	002	24.00	187.60
	1		750ML	WOODBIDGE CAB SAUV SP COL(SC)	12			913784	4.00	87.00	007	39.00	48.00
	1		750ML	WOODBIDGE PINOT GRIGIO SP COL(SC)	12			915650	4.00	87.00	007	39.00	48.00
	1		1.0L	BULLEIT BOURBON 90	12			352429	36.95	36.95	001		36.95
	1		1.0L	BULLEIT 95 RYE 90	12			443649	37.70	37.70	001		37.70
	1		1.0L	DEKUYPER BUTTERSHOTS SCHN 30	12		21163	32387	14.23	14.23	003		14.23
	1		1.0L	DEKUYPER PUCKER WATERMELON SCHN 30	12		20513	49357	14.23	14.23	003		14.23
	2		1.0L	KETEL ONE VODKA 80	12		20913	36126	38.70	38.70	001		77.40
	1		1.0L	MAKERS MARK BOURBON 90	12		21653	9998	42.73	42.73	003		42.73

C O D

NOT ON TRUCK

Thank You For Your Business

*Order 1/22/25 10:00 PM PSB*

PAGE TOTAL	CASES ORDER TOTAL	PAGE TOTAL	BOTTLES ORDER TOTAL	WINE GALLONS		CUSTOMER	PAGE	GROSS TOTAL	TOTAL DISCOUNT	PAY THIS AMOUNT
12	12	7	13	LIQUOR GALLONS		EAGLE LANDING GOLF CLUB	1			** CONT **
CARTON	DRIVER	LOADED	<small>Buyer represents that it is authorized under applicable law to purchase all the products delivered in this invoice and that all such products were ordered by Buyer and have been received without any damage, unless noted on invoice at time of delivery. SELLER EXPRESSLY DISCLAIMS ANY WARRANTY, INCLUDING OF MERCHANTABILITY OR FITNESS FOR A PARTICULAR PURPOSE. BUYER WAIVES CONSUMER, PUNITIVE, TREBLE OR STATUTORY DAMAGES OR PENALTIES. The parties agree to arbitrate any disputes between them on an individual basis in Miami, FL before the American Arbitration Association in accordance with its Commercial Arbitration Rules. The parties each waive the right to serve as a class or PAGA representative or to participate in a class or collective action in any legal proceeding between them.</small>							
12	13		INVOICE NO.	CUSTOMER NO.	NET AMOUNT	<small>If not sold separately to private home, public house, club, tavern, restaurant, hotel, or other place of entertainment, liquor and wine are subject to the terms of the liquor and wine control laws. Buyer shall be liable for the cost of all or the balance of the alcohol or tobacco tax, or 1.0% per month (not to exceed 6.0%) on the amount of the alcohol or tobacco tax, or 1.0% per month (not to exceed 6.0%) on the amount of the alcohol or tobacco tax, or 1.0% per month (not to exceed 6.0%) on the amount of the alcohol or tobacco tax, or 1.0% per month (not to exceed 6.0%) on the amount of the alcohol or tobacco tax. The buyer shall be liable for the cost of all or the balance of the alcohol or tobacco tax, or 1.0% per month (not to exceed 6.0%) on the amount of the alcohol or tobacco tax, or 1.0% per month (not to exceed 6.0%) on the amount of the alcohol or tobacco tax, or 1.0% per month (not to exceed 6.0%) on the amount of the alcohol or tobacco tax.</small>				
PUT UP	CHECK BY		3658560	85510		DELIVERY RECEIPT NO CLAIMS FOR SHORTAGES WILL BE ALLOWED UNLESS INSPECTED AND NOTED AT TIME OF DELIVERY				

SGWS

Print Name Signature

SOUTHERN GLAZER'S OF FL  
4440 OLD TAMPA HIGHWAY  
LAKELAND, FLORIDA  
33811

69

REMIT TO:  
SOUTHERN GLAZER'S OF FL  
P.O. BOX 947921  
ATLANTA, GA 30394-7921  
1-866-375-9655



ACH

INVOICE NUMBER	3658560		
ACCOUNT NUMBER	85510		
ROUTE	516	STOP	18

S EAGLE LANDING GOLF CLUB  
O 3989 EAGLE LANDING PARKWAY  
L ORANGE PARK FL 32065  
D

S EAGLE LANDING GOLF CLUB  
H 3989 EAGLE LANDING PARKWAY  
I ORANGE PARK FL 32065  
P

T **C.O.D.**  
O H

T  
O

DUPLICATE

C O D C.O.D. FINTECH  
FINTECH

PAGE 2 OF 2  
1500 3 14

LAKELAND-NIGHT BILL

LICENSE NUMBER	SALES PERSON	DELVRY INSTRUCTIONS	PHONE NUMBER	INVOICE DATE
20-01434	186	P.O.#:	904-291-5600	1/23/2025

LOC	CASES	BTLS	SIZE	DESCRIPTION	PACK	W-LOC	B-LOC	PRODUCT CODE	NET BTL PRICE	UNIT PRICE	DIV CDE	LIMIT DISCOUNT	NET AMOUNT
		1	1.0L	PINNACLE VOD CHERRY 60 PET	12			606165	22.70	22.70	003		22.70
		2	750ML	PINNACLE VOD VANILLA 60	12			966204	17.85	17.85	003		35.70
		2	1.0L	PINNACLE VOD WHIPPED 60 PET	12			606163	22.70	22.70	003		45.40
		1	1.0L	SKREWBALL WSKY PEANUT BUTTER 70	6			529073	30.20	33.20	005	3.00	30.20

000  
OTHER - ~~240~~ - 1360 122.04  
000  
WINE - ~~240~~ - 1344 148.80  
000  
LIQUOR - ~~240~~ - 1346 270.84

**C O D**  
*[Handwritten signature]*

Thank You For Your Business

*Rec'd 1/23/25*

TOTAL # BTLS: 125 YTD TOTAL DISCOUNT: 1,876.42

CASES ORDER TOTAL	BOTTLES ORDER TOTAL	WINE GALLONS	LIQUOR GALLONS	BEER GALLONS	CUSTOMER	PAGE	GROSS TOTAL	TOTAL DISCOUNT	PAY THIS AMOUNT	
12	6	13	18.76		EAGLE LANDING GOLF CLUB	2	2,439.58	459.90	<b>C O D</b> 1,979.68	
CARTON	DRIVER	LOADED	INVOICE NO.			CUSTOMER NO.			NET AMOUNT	DUE DATE
12			3658560			85510			1,979.68	1/23/2025
PUT UP	CHECK BY		DELIVERY RECEIPT: NO CLAIMS FOR SHORTAGES WILL BE ALLOWED UNLESS INSPECTED AND NOTED AT TIME OF DELIVERY							

Buyer represents that it is authorized under applicable law to purchase all the products delivered in this invoice, and that all such products were ordered by Buyer and have been received without any damage, unless noted on invoice at time of delivery. SELLER EXPRESSLY DISCLAIMS ANY WARRANTY, INCLUDING OF MERCHANTABILITY OR FITNESS FOR A PARTICULAR PURPOSE. BUYER WAIVES CONSEQUENTIAL, PUNITIVE, TREBLE OR STATUTORY DAMAGES OR PENALTIES. The parties agree to arbitrate any disputes between them in an individual case in Miami, FL, before the American Arbitration Association in accordance with its Commercial Arbitration Rules. The parties each waive the right to serve as a class or PAGA representative or to participate in a class of collective action in any legal proceeding between them.

If not paid according to terms herein, seller may resell, rework, repackage, repair, reuse or otherwise dispose of the goods, and the buyer shall be liable for the cost of collection and attorney's fees. Buyer's payment shall be the basis of the seller's liability. If the goods are damaged or destroyed, the seller shall be liable for the replacement cost of the goods, less any amount of insurance proceeds. The parties agree to arbitrate any disputes between them in an individual case in Miami, FL, before the American Arbitration Association in accordance with its Commercial Arbitration Rules. The parties each waive the right to serve as a class or PAGA representative or to participate in a class of collective action in any legal proceeding between them.



**Betsy Anderson**

---

**From:** Clay Electric <clayelectric@smarthub.coop>  
**Sent:** Thursday, January 30, 2025 8:45 AM  
**To:** Betsy Anderson  
**Subject:** Clay Electric Cooperative, Inc. Payment Confirmation

You don't often get email from clayelectric@smarthub.coop. [Learn why this is important](#)



**Payment Confirmation**

South Village Community Devel Dist,

Your payment to Clay Electrics, totaling \$9,350.00, have been processed and will be applied. Thank you.

---

**Transaction ID: 5575991**

**Payment Date:** Thursday, January 30, 2025 9:44:40 AM EST

**Account:** 9266477  
**Amount:** \$1,600.00  
**Service:** ELECTRIC SERVICE

**Account:** 9266469  
**Amount:** \$200.00  
**Service:** ELECTRIC SERVICE

**Account:** 9266478  
**Amount:** \$100.00  
**Service:** ELECTRIC SERVICE

**Account:** 9266474  
**Amount:** \$100.00  
**Service:** ELECTRIC SERVICE

**Account:** 9266481  
**Amount:** \$950.00  
**Service:** ELECTRIC SERVICE

**Account:** 9266484  
**Amount:** \$3,400.00  
**Service:** ELECTRIC SERVICE

**Account:** 9266489  
**Amount:** \$3,000.00  
**Service:** ELECTRIC SERVICE



Log in to manage your billing and payment information.

[Privacy Policy](#) | [Unsubscribe](#)



Visit us online at [ClayElectric.com](http://ClayElectric.com)  
Toll Free: (800)-224-4917

Member Name SOUTH VILLAGE COMMUNITY  
DEVEL DIST

Account # 8966956

Trustee District: 06

Statement Date: 01/08/2025

Current Bill Due Date: 01/29/2025

Previous Balance \$201.86

Payment Received 12/16/24 -\$201.86

Balance Forward \$0.00

Current Charges Due 01/29/25 \$89.95

### Important Messages

With the cold weather, your electric bill this month may reflect higher than normal energy usage. Setting your thermostat to 68 degrees or lower is recommended for the winter months. You can track your energy use, set usage alerts and more in your MyClayElectric account.

AutoPay  
Amount Due

# \$89.95

Bank Draft  
Scheduled For  
01/29/2025

Service Address: # 1 - 886 OAKLEAF PLANTATION PKWY IRRIGATION METER

Rate Schedule Description	Meter No.	Reading Dates		Readings		Multiplier	kWh Usage
		From	To	Previous	Present		
GENERAL SERVICE-NON DEMAND	152041957	12/05/24	01/04/25	32424	32938	1	514

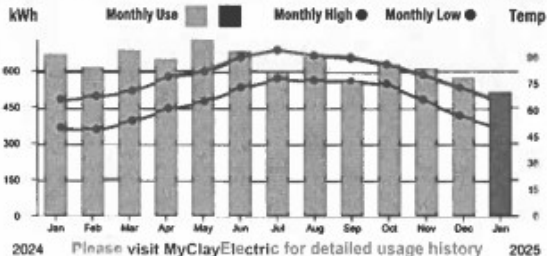

### Current Service Detail

Access Charge		\$34.00
Energy Charge	514 kWh @ 0.0833	\$42.82
Power Cost Adjustment	514 kWh @ 0.0160	\$8.22
FLA Gross Receipts Tax		\$2.18
Clay Co Public Ser Utility Tax		\$2.73
<b>Total Current Charges for this Location</b>		<b>\$89.95</b>

This Month	Last Month	This Month Last Year	Avg Daily High
514 kWh 30 days Avg kWh 17	578 kWh 31 days Avg kWh 19	671 kWh 30 days Avg kWh 22	66°F

**KEEP SEND** By accepting service from Clay Electric, you acknowledge that you have reviewed and accepted all of Clay Electric's Bylaws, Board policies and standards of service and agree to abide by them. Bills not paid in full will incur a late charge of \$5.00 or 5% of the delinquent amount (whichever is greater) that will be added to your account.



PO Box 308  
Keystone Heights, FL 32656-0308

PAY YOUR BILL 24/7

ONLINE: Check or credit/debit card at [ClayElectric.com](http://ClayElectric.com) or download the mobile app.



5631 0 MB 0.622 5 5631  
SOUTH VILLAGE COMMUNITY DEVEL DIST C-21  
5385 N NOB HILL RD  
SUNRISE FL 33351-4761

Account Number	8966956
Current Charges Due 01/29/25	\$89.95
Bank Draft scheduled for 01/29/25	\$89.95



CLAY ELECTRIC COOPERATIVE  
PO BOX 308 5  
KEYSTONE HEIGHTS, FL 32656-0308





Visit us online at [ClayElectric.com](http://ClayElectric.com)  
Toll Free: (800)-224-4917

Member Name SOUTH VILLAGE COMMUNITY

DEVEL DIST

Account # 8966958

Trustee District: 06

Statement Date: 01/08/2025

Current Bill Due Date: 01/29/2025

Previous Balance \$487.55

Payment Received 12/17/24 -\$487.55

Balance Forward \$0.00

Current Charges Due 01/29/25 \$200.74

### Important Messages

With the cold weather, your electric bill this month may reflect higher than normal energy usage. Setting your thermostat to 68 degrees or lower is recommended for the winter months. You can track your energy use, set usage alerts and more in your MyClayElectric account.

AutoPay  
Amount Due

# \$200.74

Bank Draft  
Scheduled For  
01/29/2025

Service Address: 890 OAKLEAF PLANTATION PKWY GOLF MAINTENANCE

Rate Schedule Description	Meter No.	Reading Dates		Readings		Multiplier	kWh Usage
		From	To	Previous	Present		
GENERAL SERVICE-NON DEMAND	151850799	12/05/24	01/04/25	23463	25037	1	1,574

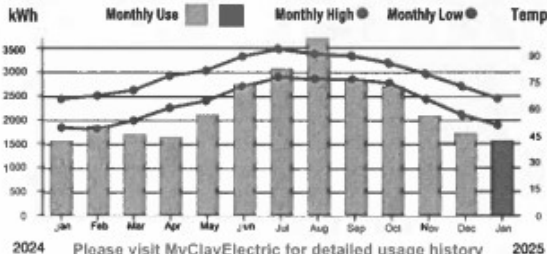

Please visit [MyClayElectric](http://MyClayElectric) for detailed usage history

### Current Service Detail

Access Charge		\$34.00
Energy Charge	1,574 kWh @ 0.0833	\$131.11
Power Cost Adjustment	1,574 kWh @ 0.0160	\$25.18
FLA Gross Receipts Tax		\$4.88
Clay Co Public Ser Utility Tax		\$5.57
<b>Total Current Charges for this Location</b>		<b>\$200.74</b>

This Month	Last Month	This Month Last Year	Avg Daily High
1,574 kWh 30 days Avg kWh 52	1,727 kWh 31 days Avg kWh 56	1,532 kWh 30 days Avg kWh 53	66°F

**KEEP SEND** By accepting service from Clay Electric, you acknowledge that you have reviewed and accepted all of Clay Electric's Bylaws, Board policies and standards of service and agree to abide by them. Billings not paid in full will incur a late charge of \$5.00 or 5% of the delinquent amount (whichever is greater) that will be added to your account.



PO Box 308  
Keystone Heights, FL 32656-0308

PAY YOUR BILL 24/7

ONLINE: Check or credit/debit card at [ClayElectric.com](http://ClayElectric.com) or download the mobile app.



Account Number	8966958
Current Charges Due 01/29/25	\$200.74
Bank Draft scheduled for 01/29/25	\$200.74



CLAY ELECTRIC COOPERATIVE  
PO BOX 308



Visit us online at [ClayElectric.com](http://ClayElectric.com)  
Toll Free: (800)-224-4917

Member Name SOUTH VILLAGE COMMUNITY  
DEVEL DIST

Account # 8966960  
Trustee District: 06  
**Statement Date: 01/08/2025**  
**Current Bill Due Date: 01/29/2025**

Previous Balance \$1,047.80  
Payment Received 12/17/24 -\$1,047.80  
**Balance Forward \$0.00**  
**Current Charges Due 01/29/25 \$446.59**

**Important Messages**

With the cold weather, your electric bill this month may reflect higher than normal energy usage. Setting your thermostat to 68 degrees or lower is recommended for the winter months. You can track your energy use, set usage alerts and more in your MyClayElectric account.

AutoPay  
Amount Due

\$446.59

Bank Draft  
Scheduled For  
01/29/2025

Service Address: 3981 OAKLEAF PLANTATION PKWY GOLF CART BARN

Rate Schedule Description	Meter No.	Reading Dates		Readings		Multiplier	kWh Usage
		From	To	Previous	Present		
GENERAL SERVICE-NON DEMAND	151835305	12/05/24	01/04/25	22644	26570	1	3,926

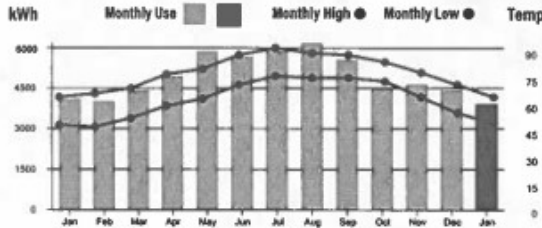

**Current Service Detail**

Access Charge		\$34.00
Energy Charge	3,926 kWh @ 0.0833	\$327.04
Power Cost Adjustment	3,926 kWh @ 0.0160	\$62.82
FLA Gross Receipts Tax		\$10.87
Clay Co Public Ser Utility Tax		\$11.86
<b>Total Current Charges for this Location</b>		<b>\$446.59</b>

2024 Please visit MyClayElectric for detailed usage history 2025

This Month	Last Month	This Month Last Year	Avg Daily High
3,926 kWh 30 days Avg kWh 131	4,419 kWh 31 days Avg kWh 143	4,092 kWh 30 days Avg kWh 136	66°F

**KEEP SEND** By accepting service from Clay Electric, you acknowledge that you have reviewed and accepted all of Clay Electric's Bylaws, Board policies and standards of service and agree to abide by them. Billings not paid in full will incur a late charge of \$5.00 or 5% of the delinquent amount (whichever is greater) that will be added to your account.



PO Box 308  
Keystone Heights, FL 32656-0308

**PAY YOUR BILL 24/7**  
ONLINE: Check or credit/debit card at [ClayElectric.com](http://ClayElectric.com) or download the mobile app.



SOUTH VILLAGE COMMUNITY DEVEL DIST  
5385 N. NOB HILL ROAD  
SUNRISE FL 33351-0000

Account Number	8966960
Current Charges Due 01/29/25	\$446.59
Bank Draft scheduled for 01/29/25	\$446.59



CLAY ELECTRIC COOPERATIVE  
PO BOX 308  
KEYSTONE HEIGHTS, FL 32656-0308





Visit us online at [ClayElectric.com](http://ClayElectric.com)  
Toll Free: (800)-224-4917

Member Name SOUTH VILLAGE COMMUNITY

DEVEL DIST

Account # 8966957

Trustee District: 06

Statement Date: 01/08/2025

Current Bill Due Date: 01/29/2025

Previous Balance \$2,623.80

Payment Received 12/17/24 -\$2,623.80

Balance Forward \$0.00

Current Charges Due 01/29/25 \$1,066.41

**Important Messages**

With the cold weather, your electric bill this month may reflect higher than normal energy usage. Setting your thermostat to 68 degrees or lower is recommended for the winter months. You can track your energy use, set usage alerts and more in your MyClayElectric account.

AutoPay  
Amount Due

# \$1,066.41

Bank Draft  
Scheduled For  
01/29/2025

Service Address: 886 OAKLEAF PLANTATION GOLF IRRIG PUMP

Rate Schedule Description	Meter No.	Reading Dates		Readings		Multiplier	kWh Usage
		From	To	Previous	Present		
GENERAL SERVICE DEMAND	152192941	12/05/24	01/04/25	11583	11764	40	7,240

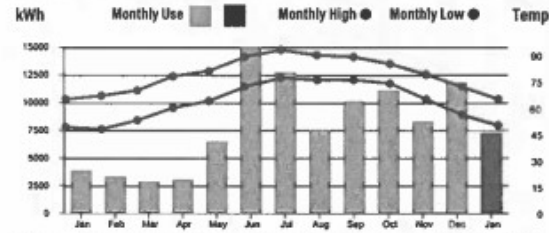

**Current Service Detail**

Access Charge		\$80.00
Energy Charge	7,240 kWh @ 0.0600	\$434.40
Power Cost Adjustment	7,240 kWh @ 0.0160	\$115.84
Demand Charge	87.200 KW @ 4.3500	\$379.32
FLA Gross Receipts Tax		\$25.87
Clay Co Public Ser Utility Tax		\$30.98
<b>Total Current Charges for this Location</b>		<b>\$1,066.41</b>

This Month	Last Month	This Month Last Year	Avg Daily High
7,240 kWh 30 days Avg kWh 241	11,840 kWh 31 days Avg kWh 382	3,960 kWh 30 days Avg kWh 132	66°F



By accepting service from Clay Electric, you acknowledge that you have reviewed and accepted all of Clay Electric's Bylaws, Board policies and standards of service and agree to abide by them. Billings not paid in full will incur a late charge of \$5.00 or 5% of the delinquent amount (whichever is greater) that will be added to your account.



PO Box 308  
Keystone Heights, FL 32656-0308

PAY YOUR BILL 24/7

ONLINE: Check or credit/debit card at [ClayElectric.com](http://ClayElectric.com) or download the mobile app.



SOUTH VILLAGE COMMUNITY DEVEL DIST  
5385 N. NOB HILL ROAD  
SUNRISE FL 33351-0000

Account Number	8966957
Current Charges Due 01/29/25	\$1,066.41
Bank Draft scheduled for 01/29/25	\$1,066.41



CLAY ELECTRIC COOPERATIVE  
PO BOX 308 5  
KEYSTONE HEIGHTS, FL 32656-0308







Visit us online at [ClayElectric.com](http://ClayElectric.com)  
Toll Free: (800)-224-4917

Member Name SOUTH VILLAGE COMMUNITY

DEVEL DIST

Account # 8966961

Trustee District: 06

Statement Date: 01/08/2025

Current Bill Due Date: 01/29/2025

Previous Balance \$4,103.78

Payment Received 12/17/24 -\$4,103.78

Balance Forward \$0.00

Current Charges Due 01/29/25 \$1,777.05

**Important Messages**

With the cold weather, your electric bill this month may reflect higher than normal energy usage. Setting your thermostat to 68 degrees or lower is recommended for the winter months. You can track your energy use, set usage alerts and more in your MyClayElectric account.

AutoPay  
Amount Due

# \$1,777.05

Bank Draft  
Scheduled For  
01/29/2025

Service Address: 3989 EAGLE LANDING PKWY GOLF CLUBHOUSE

Rate Schedule Description	Meter No.	Reading Dates		Readings		Multiplier	kWh Usage
		From	To	Previous	Present		
GENERAL SERVICE DEMAND	174322869	12/15/24	01/04/25	12320	12766	40	17,840

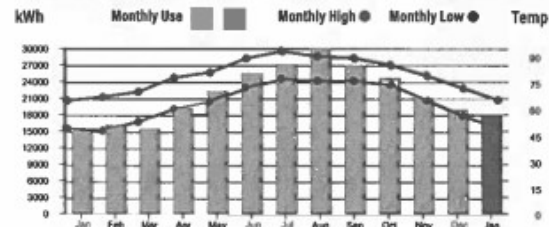

2024 Please visit MyClayElectric for detailed usage history 2025

**Current Service Detail**

Access Charge		\$80.00
Energy Charge	17,840 kWh @ 0.0600	\$1,070.40
Power Cost Adjustment	17,840 kWh @ 0.0160	\$285.44
Demand Charge	58.280 KW @ 4.3500	\$253.52
FLA Gross Receipts Tax		\$43.29
Clay Co Public Ser Utility Tax		\$14.40
<b>Total Current Charges for this Location</b>		<b>\$1,777.05</b>

This Month	Last Month	This Month Last Year	Avg Daily High
17,840 kWh 30 days Avg kWh 595	19,000 kWh 31 days Avg kWh 613	14,800 kWh 30 days Avg kWh 493	66°F



By accepting service from Clay Electric, you acknowledge that you have reviewed and accepted all of Clay Electric's Bylaws, Board policies and standards of service and agree to abide by them. Billings not paid in full will incur a late charge of \$5.00 or 5% of the delinquent amount (whichever is greater) that will be added to your account.



PO Box 308  
Keystone Heights, FL 32656-0308

**PAY YOUR BILL 24/7**  
ONLINE: Check or credit/debit card at [ClayElectric.com](http://ClayElectric.com) or download the mobile app.



Account Number	8966961
Current Charges Due 01/29/25	\$1,777.05
Bank Draft scheduled for 01/29/25	\$1,777.05



CLAY ELECTRIC COOPERATIVE

9I - South Village CDD dba Eagle Landing      Pg 1  
 1015 - Capital Reserve Fund  
 Check Register for Jan 1/25 thru Jan 31/25  
 Regular Checks

Check	Issued to:	Date	Check Amount	Note
1266	COMMERCIAL FITNESS PRODUCTS	Jan 3/25	3,756.60	
1267	PERFORMANCE PAINTING CONTRACTORS IN	Jan 3/25	2,323.34	
1268	T&M ELECTRIC	Jan 3/25	1,188.64	
1269	E-Z-GO DIV OF TEXTRON	Jan 23/25	2,500.00	
1270	TAYLOR TENNIS & MORE LLC	Jan 30/25	1,200.00	
1271	WEBWATCHDOGS	Jan 30/25	16,075.00	
Total Regular Checks Issued			27,043.58	

===== End of Report =====

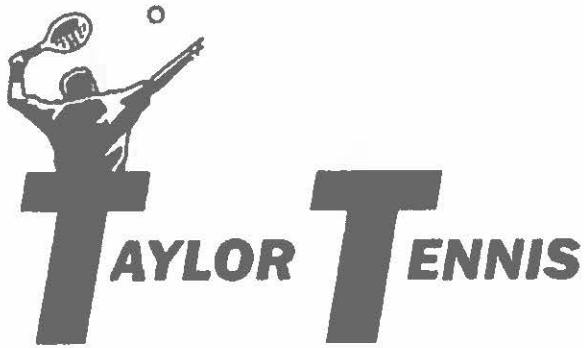

Taylor Tennis & More  
9418224490  
PO BOX 971  
Ellenton, FL 34222

Billed To  
Eagle Landing  
Orange Park, FL 32065

Date of Issue  
01/27/2025

Invoice Number  
C 1286

Due Date  
01/28/2025

Amount Due (USD)  
**\$1,200.00**

Description	Rate	Qty	Line Total
current gate being relocated to allow access to both courts	\$1,200.00	1	\$1,200.00

Subtotal 1,200.00

Tax 0.00

Total 1,200.00

Amount Paid 0.00

Amount Due (USD) \$1,200.00

Notes  
Thank you for your business!

Terms  
per due date

7975-900  
'Pickleball Courts'

*CHANGEL RESERVE  
PICKLE BALL COURTS*

*APK  
1/28/25*



# WEBWATCHDOGS

SURVEILLANCE CAMERA SYSTEMS

# Invoice

1 Hargrove Grade Suite 1A  
 Palm Coast, FL 32137  
 (386) 957-9339  
 (866) 896-9055 Fax  
 www.WebWatchdogs.net  
 info@WebWatchdogs.net  
 Florida Contractor License #ES12000771

Date	Invoice #
1/21/2025	9765
East West Communities-Eagle Landing 3973 Eagle Landing Pkwy Orange Park, FL 32065	

Description	Qty	Rate	Amount	
<b>*****MAIN ENTRANCE*****</b>				
4K 8 Channel NDAA NVR-NDAA performance series 4K / 8, Megapixel Ultra HD 8 channel NVR with 8 x PoE, ports and H.265 compression. Supports 8 x 8MP IP cameras; Max 160Mbps incoming bandwidth, Supports people counting and crowd density, monitoring if paired with compatible camera. 1/1 Audio In / Out, 4/1 Alarm / Relays. 2 x SATA forup to 2 x 10TB Hard Drives; 1 x 4TB Hard Drive ***Includes Installation***	1	1,000.00	1,000.00	
NDAA compliant 4 MP H.265 IP armor ball camera with an ultra wide 2.8mm fixed lens, built-in mic, True WDR, and up to 98ft IR with a minimum Lux of 0.01 (0 Lux IR on). Supports motion detect and triple-streaming. IP67 weatherproof with a voltage range of +/- 25%, and 2KV surge protection. Record on the edge with 256GB memory card (not included) or locally with an Optiview NVR or DVR. DC 12V±25%, PoE (IEEE 802.3af) power. ***Includes Installation***	2	450.00	900.00	
NDAA compliant 2 Megapixel IP Network ANPR License Plate capture camera with 4.7-47mm Motorized Lens. Capture License Plates up to 98ft / 56mph. Boast 95% vehicle capture rate, and supports vehicle color recognition, and ANPR license plate capture. Holds optional memory card up to 128GB. Interface includes 1 x ethernet, 1 x RS485, 2 / 1 Alarm In / Out, 1 / 1 Audio In / Out. H.265 Compression. DC12V + 25% - 10%. IP67 Weatherproof. ***Includes Installation***	2	1,700.00	3,400.00	
5G Long Range PTP 867MBPS Wireless Bridge W/ POE Injector- 867 Mbps Wireless Speed, 2.17mi Wireless Range, 4.92GHz to 5.92GHz Frequency Range Includes PoE Injector ***Includes Installation***	1	650.00	650.00	
Additional Installation Supplies & Labor- Cat6 Cable, Conduit, PVC, Junction Boxes, Miscellaneous Hardware, Network Configuration, Remote Access Set Up	1	800.00	800.00	
Supply & Install Decorative Aluminum Post Per Customer Request	1	225.00	225.00	
Extended Warranty Option- Complete Surveillance Camera System (\$675 Per Year After the 1st Year For Complete System- Parts & Labor)		0.00	0.00	
<b>1 Year Extended Warranty on Camera Parts, Labor and Equipment</b> All products are warranted for 1 year from date of purchase. If a product is defective we will repair or replace it. The following situations void the product warranty: Adding 3rd party software to a DVR without prior approval from our technical support department. Damage caused by nature such as flooding, winds, lightning and other similar events. Damage caused by vandalism. Network related issues involving your internet service provider (i.e. new modem, change of internet provider, etc.) Warranty Service Calls will be addressed within a 1-5 day time frame. After 1 year (outside of the warranty, if not extended), we will continue to support the product at the standard repair labor rate (currently \$199 per hour-minimum 2 hours) plus parts, if applicable, or phone technical support for \$65.00/hour. Out of warranty repairs are guaranteed for 30 days. Phone support is non-refundable.			<b>Subtotal</b>	\$6,975.00
			<b>Sales Tax (0.0%)</b>	\$0.00
			<b>Total</b>	\$6,975.00
			<b>Payments/Credits</b>	\$0.00
			<b>Balance Due</b>	\$6,975.00

# WEBWATCHDOGS

## SURVEILLANCE CAMERA SYSTEMS

# Invoice

1 Hargrove Grade Suite 1A  
 Palm Coast, FL 32137  
 (386) 957-9339  
 (866) 896-9055 Fax  
 www.WebWatchdogs.net  
 info@WebWatchdogs.net  
 Florida Contractor License #ES12000771

Date	Invoice #
12/4/2024	C 9672
East West Communities-Eagle Landing 3973 Eagle Landing Pkwy Orange Park, FL 32065	

Description	Qty	Rate	Amount
NDAA Compliant 4K / 12MP 16 Channel NVR with 16x PoE ports and Ultra 265 compression. Supports 10 x 1080P @ 30FPS. Maximum 320Mbps incoming and outgoing with AI disabled and maximum 160 Mbps with AI enabled. Supports Perimeter Protection, ID+, Fisheye, LPR, People Flow Counting, Tripwire, Intrusion and Abandoned & Missing Object. This recorder meets NDAA compliance and includes 1/1 Audio In/Out, 8/2 Alarm In/Out, 2x USB (1x2.0 & 1x3.0), 1x HDMI, 1x VGA, 1x RS485 and 2x SATA ports up to 2 x 10 <b>***Includes Installation***</b>	1	1,900.00	1,900.00
NDAA compliant 4 MP H.265 IP armor ball camera with an ultra wide 2.8mm fixed lens, built-in mic, True WDR, and up to 98ft IR with a minimum Lux of 0.01 (0 Lux IR on). Supports motion detect and triple-streaming. IP67 weatherproof with a voltage range of +/- 25%, and 2KV surge protection. Record on the edge with 256GB memory card (not included) or locally with an Optiview NVR or DVR. DC 12V±25%, PoE (IEEE 802.3af) power. <b>***Includes Installation***</b>	6	450.00	2,700.00
Additional Installation Supplies & Labor- Cat5 Cable, Conduit, PVC, Junction Boxes, Miscellaneous Hardware, Network Configuration, Remote Access Set Up	1	4,500.00	4,500.00
Extended Warranty Option- Complete Surveillance Camera System (\$900 Per Year After the 1st Year For Complete System- Parts & Labor)		0.00	0.00
<p><b>1 Year Extended Warranty on Camera Parts, Labor and Equipment</b>            All products are warranted for 1 year from date of purchase. If a product is defective we will repair or replace it. The following situations void the product warranty: Adding 3rd party software to a DVR without prior approval from our technical support department. Damage caused by nature such as flooding, winds, lightning and other similar events. Damage caused by vandalism. Network related issues involving your internet service provider (i.e. new modem, change of internet provider, etc.) Warranty Service Calls will be addressed within a 1-5 day time frame.</p> <p>After 1 year (outside of the warranty, if not extended), we will continue to support the product at the standard repair labor rate (currently \$199 per hour-minimum 2 hours) plus parts, if applicable, or phone technical support for \$65.00/hour. Out of warranty repairs are guaranteed for 30 days. Phone support is non-refundable.</p>	<b>Subtotal</b>		\$9,100.00
	<b>Sales Tax (0.0%)</b>		\$0.00
	<b>Total</b>		\$9,100.00
	<b>Payments/Credits</b>		\$0.00
	<b>Balance Due</b>		\$9,100.00